



**PLEASE INSPECT YOUR PRODUCT FOR DAMAGE  
BEFORE PROCEEDING TO INSTALLATION**

Thank you for choosing Dee Zee to add function and accessorize your vehicle. Dee Zee has been a staple brand in the truck accessory market since 1977 and we hold a reputation of quality manufacturing based in America's Heartland. Our products are born through careful engineering and backed by industry leading warranty programs. We appreciate the opportunity to serve you and your vehicle!

**Review the instruction pages in their entirety to prepare the required tools**





**Note:** This product is an appearance accessory and should not be relied upon as protection for the vehicle occupants in the event of an accident. Buyer assumes all risk, liability, and costs for vehicle impact operations.

Any modifications or unintended use of this product shall immediately void all manufacturers' warranties. Dee Zee, Inc. disclaims all liability for injuries to persons or property resulting from modifications or unintended use of this product.

**Cleaning:** To be entitled to all warranty rights offered with the product, Dee Zee liquid transfer tanks need to be cleaned regularly with a mild detergent. Do NOT use abrasive cleaners.

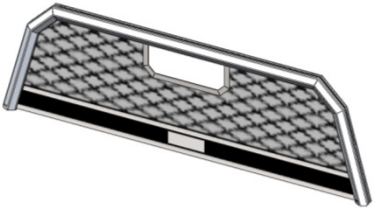
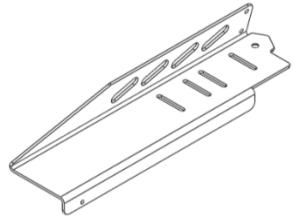
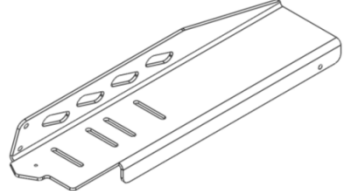
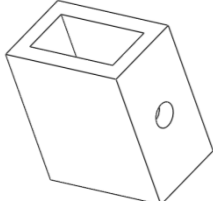
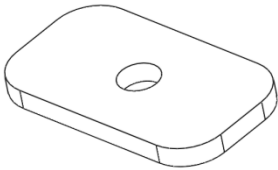
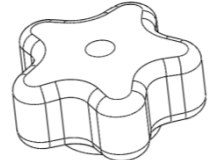
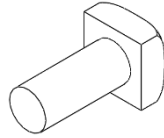
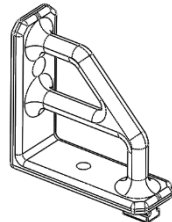
**Aluminum Cab Rack**

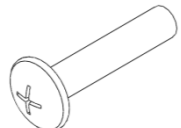
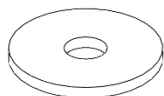
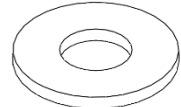
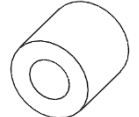
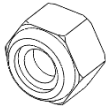
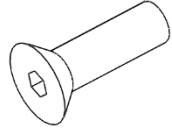
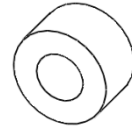
## Cab Rack Installation Instructions

<p><b>A</b> Cab Rack</p>  <p>Varies X1</p>	<p><b>B</b> Left Bolt-On Mount</p>  <p>Varies X1</p>	<p><b>C</b> Right Bolt-On Mount</p>  <p>Varies X1</p>	
<p><b>D</b> Rubber Mounting Block</p>  <p>SR RUBMNT1 X2</p>	<p><b>E</b> 3/8" Threaded Plate</p>  <p>PN 407 X2</p>	<p><b>F</b> Knob</p>  <p>WQ500-KNOB X2</p>	
<p><b>G</b> Square Head Bolt</p>  <p>PN 524 X6</p>	<p><b>H</b> Tie Down</p>  <p>TD95P X2</p>	<p><b>I</b> 3/8" x 3.5" Bolt</p>  <p>PN 620 X2</p>	
<p><b>J</b> 1/4" Phillips Head Screw</p>  <p>PN 485 X2</p>	<p><b>K</b> 1/4" Fender Washer</p>  <p>PN 265 X2</p>	<p><b>L</b> 3/8" Washer</p>  <p>PN 113 X2</p>	<p><b>M</b> 1/4" x 1/2" Nylon Spacer</p>  <p>PN 703 X2</p>
<p><b>N</b> 1/4" Locknut</p>  <p>PN 341 X2</p>	<p><b>O</b> 3/8-1.25" Flat Socket Bolt</p>  <p>PN 353 X2</p>	<p><b>P</b> 7/16" x 1/2" Nylon Spacer</p>  <p>PN 1060 X2</p>	<p><b>Q</b> 5/16" SAE Washer</p>  <p>PN 339 X4</p>

**Aluminum Cab Rack**

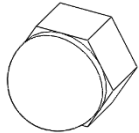
**R****M8 Acorn Cap Nut**

PN 1038

X4

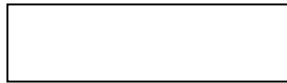
**S****Adhesive Pad**

FGT 12

X2

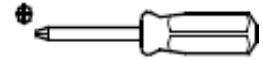
**Tools Required****Allen Wrench**4mm  
5mm  
7/32"Phillips Head  
Screwdriver**Drill**

1/4" Drill Bit

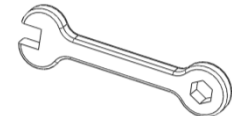
**Ratchet and Socket  
or Wrench**  
13mm**1 Driver Side – Brace Mount**

Install Hardware **(G)** Square Head Bolt, **(Q)** 5/16" Washer, and **(R)** M8 Acorn Nut onto the **(B)** Left Bolt-On Mount as shown. Leave hardware loose.

\* **Passenger side** follows same steps as in Driver side installation.\*

Brackets Needed: **C**

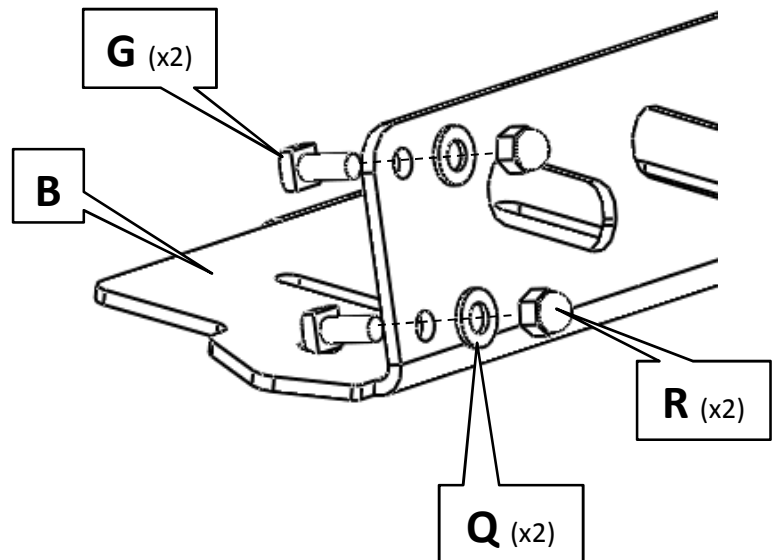

## 2 Driver Side – Brace Mount

Align **(G)** Square Head Bolt with the channel in **(A)** Cab Rack frame upright tube. Slide **(B)** Left Bolt-On Brace with hardware down channel until flush with bottom of **(A)** Cab Rack frame upright tube.

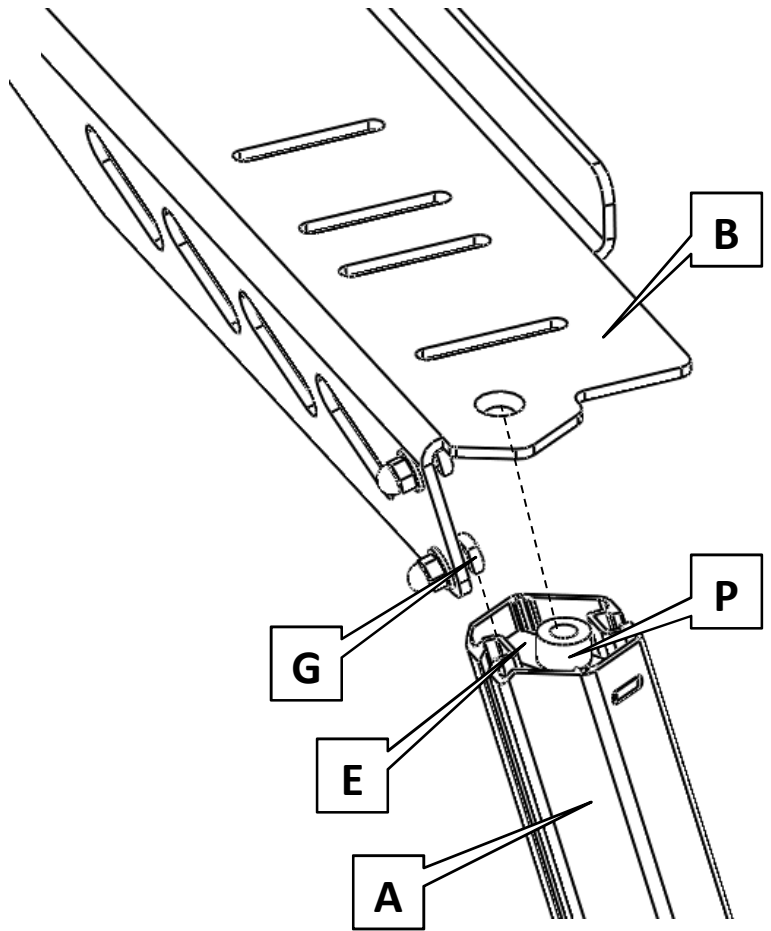

Align **(P)** 3/8-1.25" Flat Socket Bolt with the countersunk hole in **(B)** Left Bolt-On Brace ensuring **(P)** 7/16" x 1/2" Nylon Spacer stays in place on top of the Threaded Plate. Tighten Hardware.

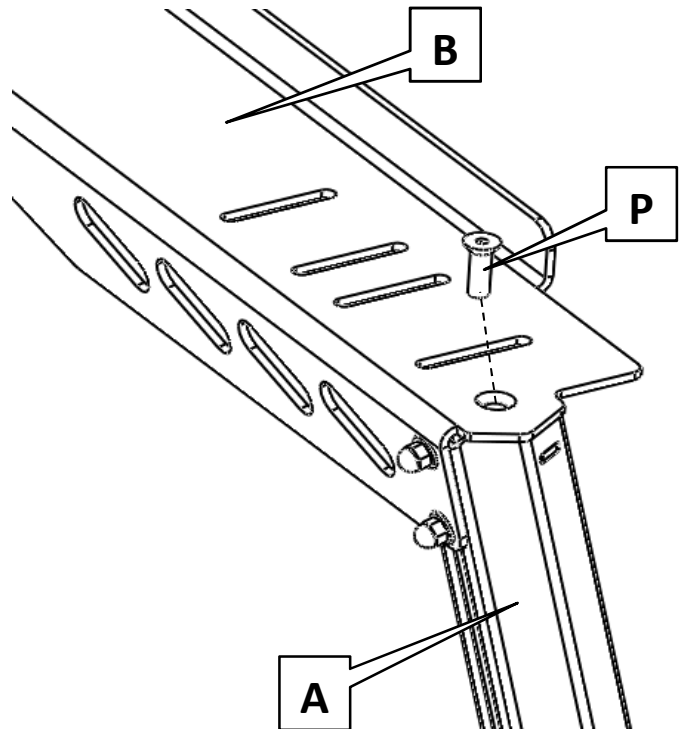

**\* Tighten All Hardware \***

**\* Passenger side** follows same steps as in Driver side installation.\*

Brackets Needed: **C**

### 3 Driver Side – Brace Mount

Peel backing off of (S)  
Adhesive Foam Pad and  
place on the bottom of each  
(B) and (C).

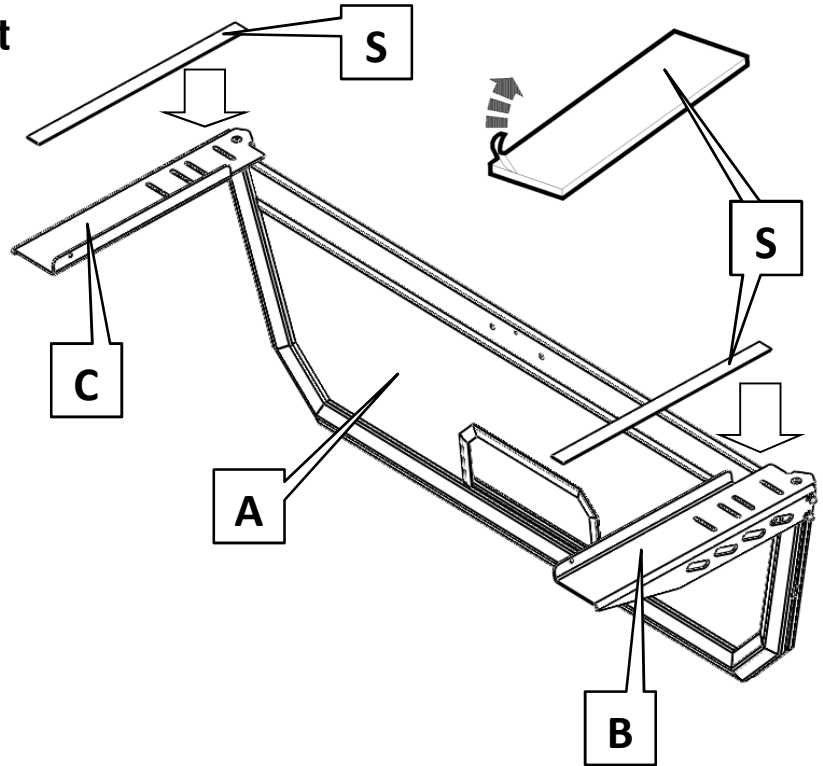

### 4 Cab Rack Installation

Place Assembled Cab Rack  
onto front side bed rails of  
truck

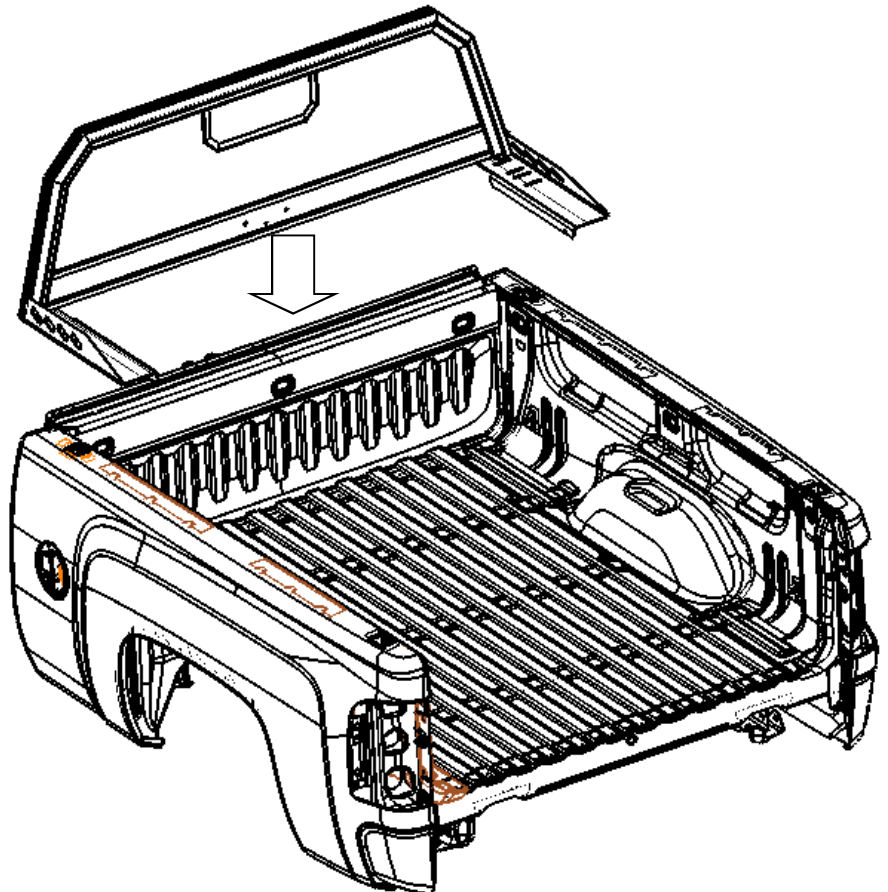

## 5 Cab Rack Installation

Mark the slot in the Bolt-On Mounting Bracket that lines up with the stake pocket holes in the top of the truck bed rails.

\* If your Cab Rack does not line up with a stake pocket hole, refer to end of installation instruction\*

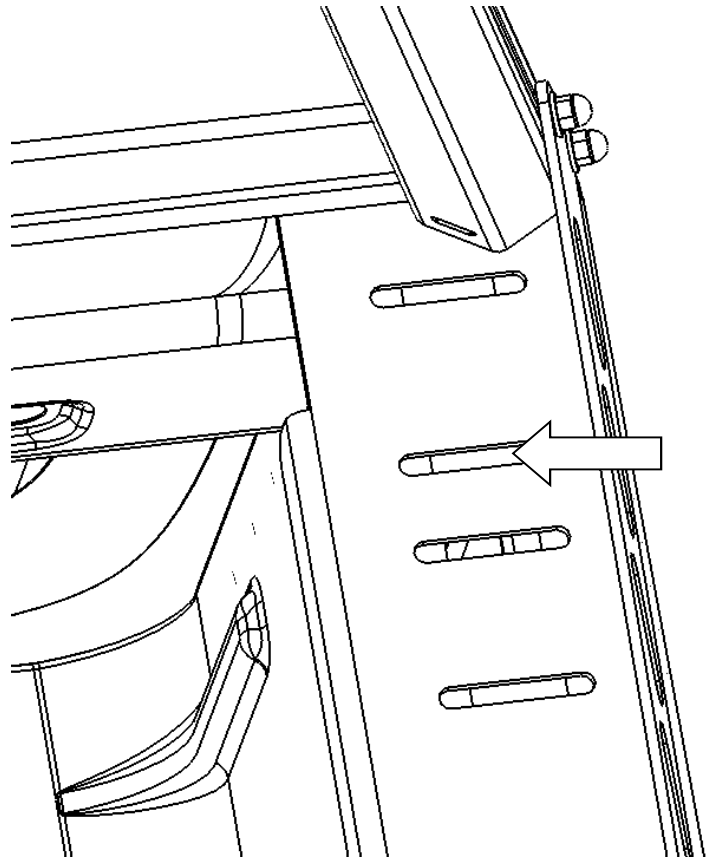

6

Remove Cab Rack from truck bed and install hardware as shown in the marked slot of the Bolt-On Mounting Bracket

X2

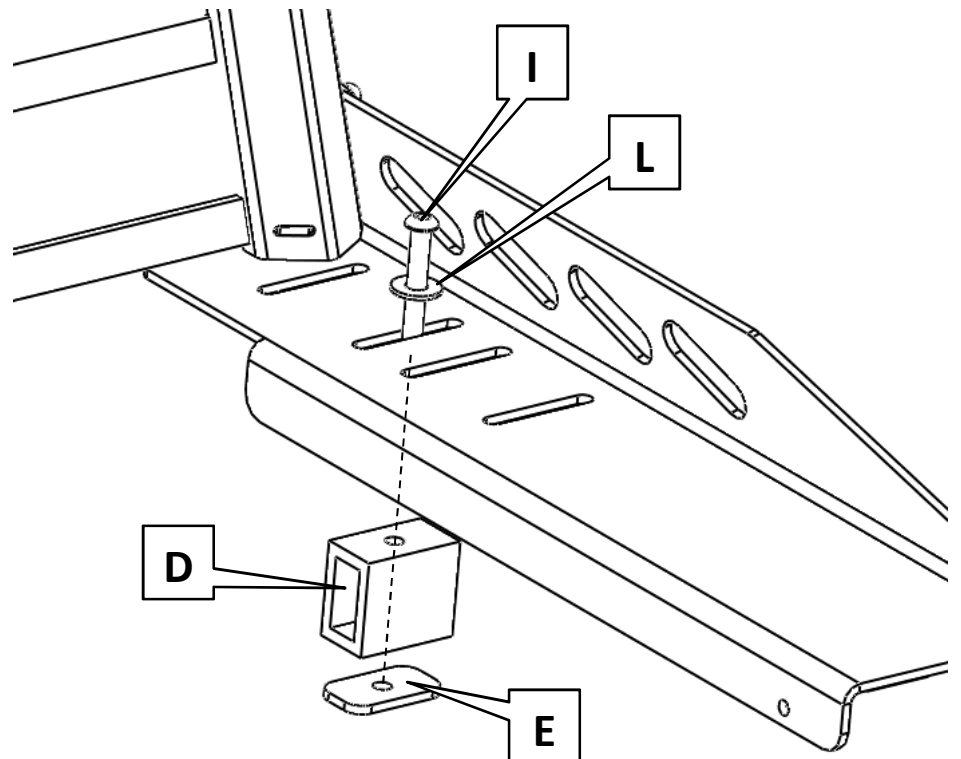

Aluminum Cab Rack

## 7 Cab Rack Installation

Place Assembled Cab Rack onto front side bed rails of truck inserting rubber mounting blocks into the stake pocket holes in the top of the truck bed rails. Tighten hardware till cab rack is snug.

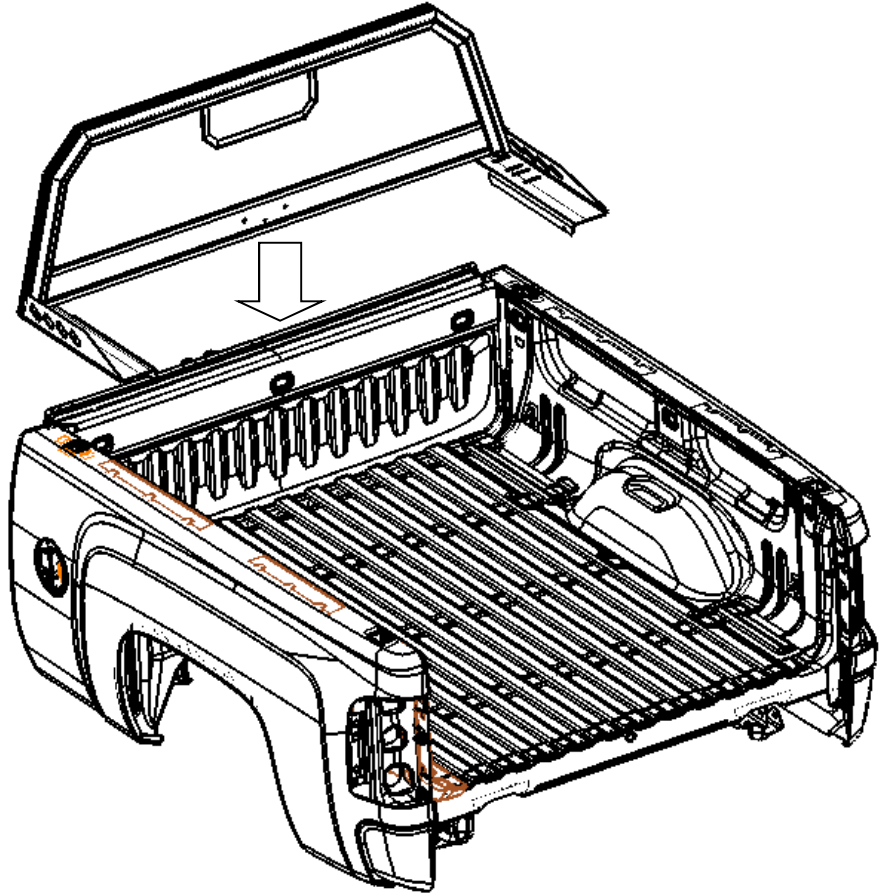

## 8

Mark hole on the inside vertical lip of the truck bed and drill using 1/4" drill bit

**X2**

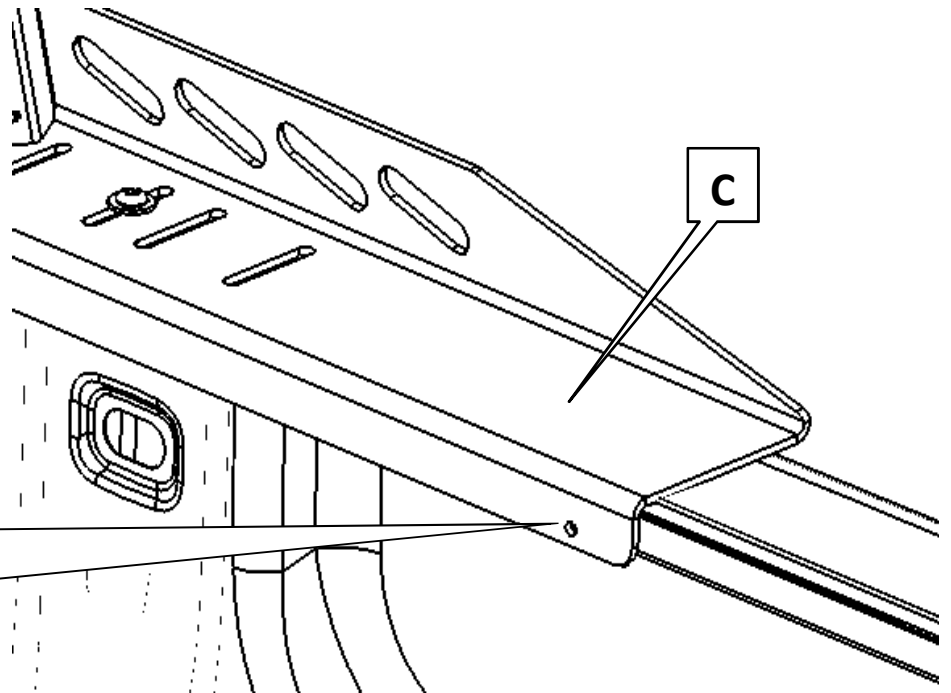

**Aluminum Cab Rack**

**9**

## Cab Rack Installation

Install hardware as shown in the drilled hole on the inside vertical lip of the truck bed and the Bolt-On Mounting Bracket

**X2**

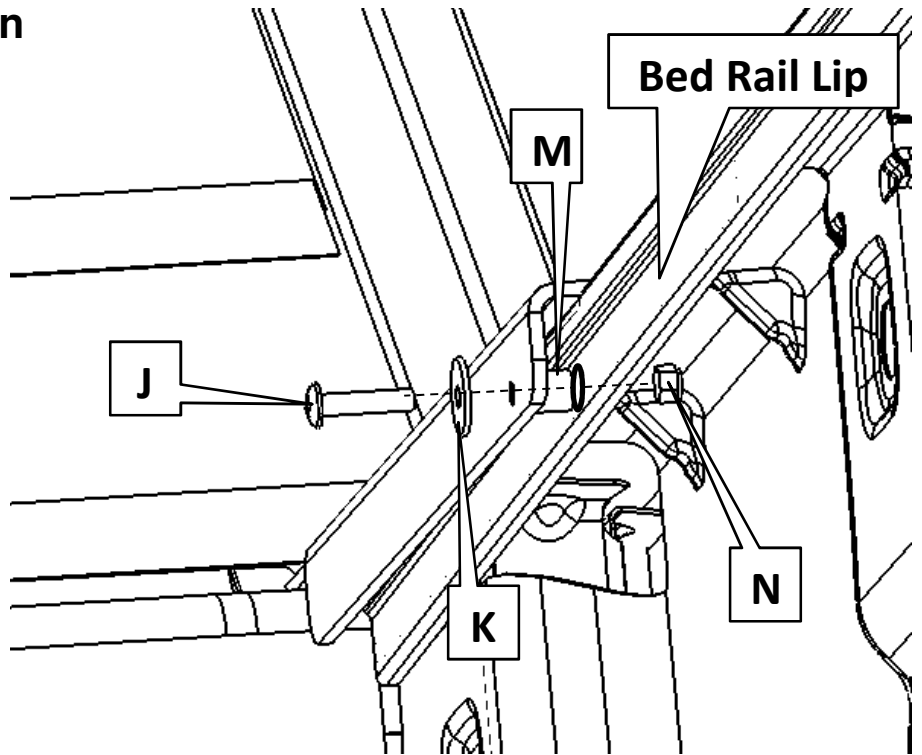

**10**

## Tie Down Installation

Optionally, to Install (H) Tie Downs use hardware as shown in the milled slots of the Cab Rack Tube Frame

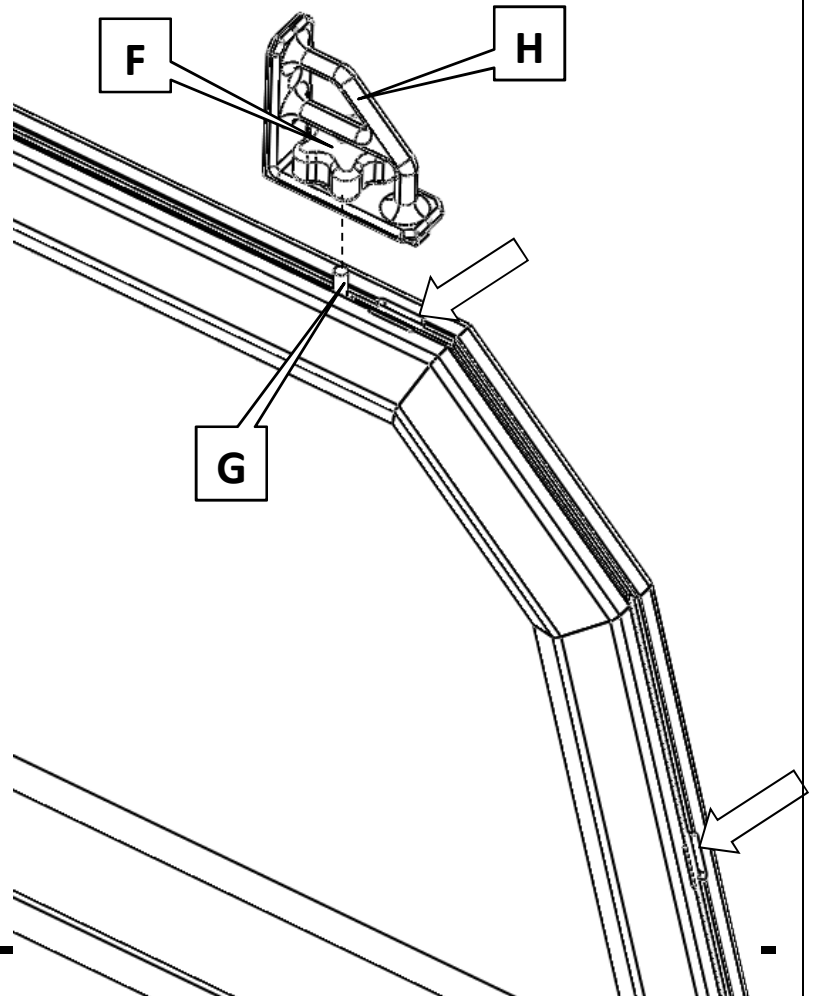

**Aluminum Cab Rack**



---

## Stake Pocket Mislocation

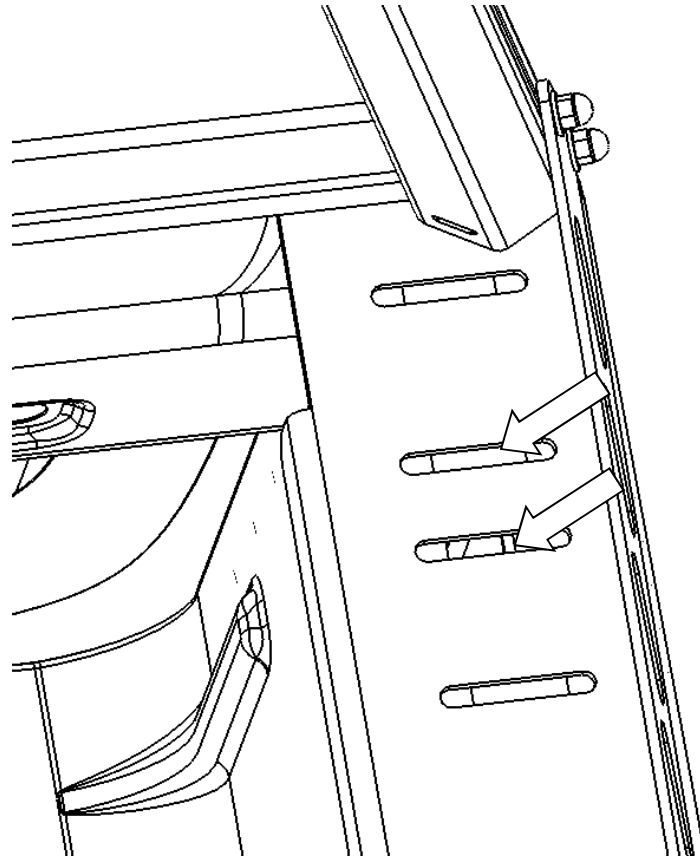

**Should your Cab Rack not have any of the available slots line up with the stake pocket holes, or the available slots do not allow the rubber mounting block to insert properly, drill a hole into the Cab Rack Mounting Plate to properly line up with the stake pocket hole.**