

## Tailgate Protector

### Hardware Kit Contents:

26 Screws

### Installation Instructions:

1. Wash truck tailgate thoroughly with a multi purpose degreaser.
2. Allow to dry completely prior to installing ProTecta tailgate protector.
3. Place tailgate protector on clean, dry, debris free tailgate. Make sure holes line up with lower horizontal rib as shown in Fig. 2.
4. Using a 9/64 drill bit, drill a hole in one corner.
5. Insert screw and washer into hole just drilled.
6. Reposition tailgate protector in needed. Drill remaining holes.  
Note: maximum of 26 holes/screws per tailgate/
7. Remove the tailgate any debris from drilling. Fasten tailgate protector into the remaining screws and washers. (See Fig. 1.)

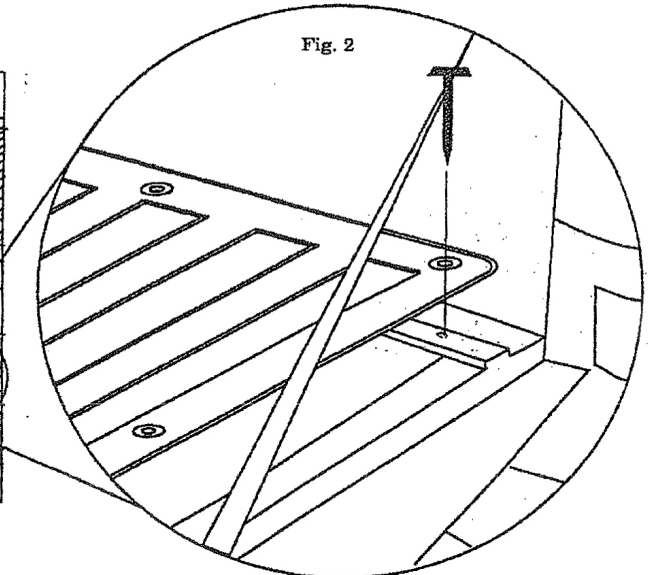
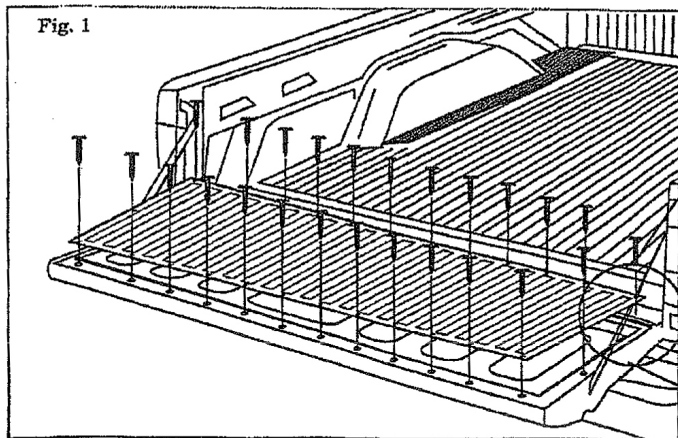

Your new Tailgate Protector is highly resistant to gasoline, kerosene, fuel oil and solvent spills as long as cleaning recommendations are followed immediately.

#### Tailgate Protector Cleaning Recommendations

1. Promptly remove any standing liquid or debris from tailgate protector
2. Flush with water
3. Allow to air dry

Line up bottom of tailgate protector with bottom of tailgate

*Tailgates are made from 100% post-industrial recycled SBR rubber with an added fiber reinforcement to improve service life and durability. Some visible cord is to be expected and does not detract from the function of the mat nor is it considered to be a defect.*