



**PLEASE INSPECT YOUR PRODUCT FOR DAMAGE
BEFORE PROCEEDING TO INSTALLATION.**

INSTRUCTIONS FOR RETURNS:

ALL PRODUCTS NEED RETURNED TO POINT OF PURCHASE
FOR WARRANTY DEFECTS, DAMAGES, OR RETURNS.



Dee Zee Toolbox Installation Instructions

Congratulations on your purchase of a quality Dee Zee product. Dee Zee is recognized as having the highest quality running boards and accessories on the market today. We have earned this reputation by offering our customers a product they can be proud to place on their vehicles. Dee Zee meets all the criteria of manufacturing a custom-fit product which guarantees it to be the easiest product to install.

Note: Please take time to read all of the instruction before beginning this installation.

Note: Unless you are using a Dee Zee premium tool box mounting kit, use J-bolt provided or the **WARRANTY IS VOID.**
DO NOT USE self tapping screws to mount.

Dee Zee Brite Tread Tool Box Installation Instruction

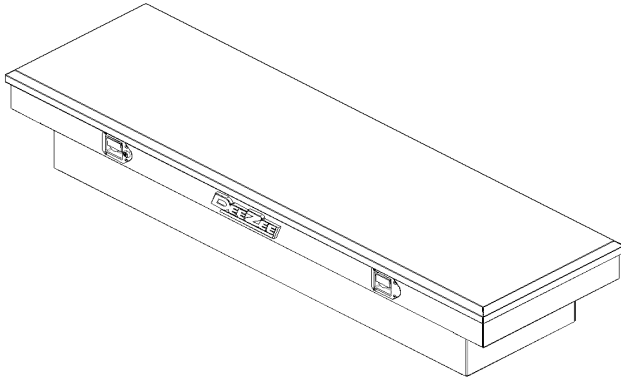
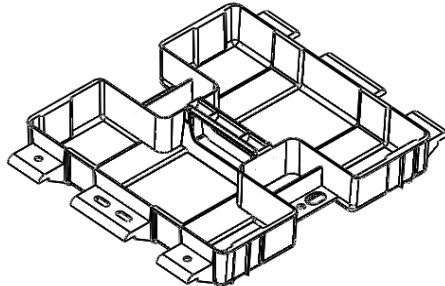
<div style="display: flex; justify-content: space-between;"> A TOOL BOX </div>  <p>Although a single lid tool box is pictured, this instruction works for all cross over boxes.</p>	<div style="display: flex; justify-content: space-between;"> B TRAY (OPTIONAL) </div>  <p>NOTE: NOT ALL TOOL BOX MODELS COME WITH A TRAY.</p>
---	--

VARIES
X1
TBTRAY-18A
X1

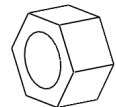
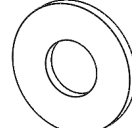
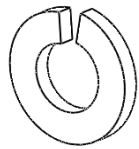
<div style="display: flex; justify-content: space-between;"> C J-BOLT </div>  <p>PN 549 X2</p>	<div style="display: flex; justify-content: space-between;"> D 3/8" NUT </div>  <p>PN 90 X2</p>	<div style="display: flex; justify-content: space-between;"> E 3/8" WASHER </div>  <p>PN 113 X2</p>	<div style="display: flex; justify-content: space-between;"> F 3/8" LOCK WASHER </div>  <p>PN 89 X2</p>
--	---	--	---

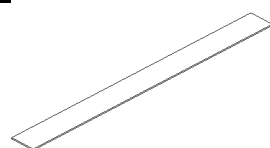
<div style="display: flex; justify-content: space-between;"> G VINYL CAP </div>  <p>PN 550 X2</p>	<div style="display: flex; justify-content: space-between;"> H GASKET </div>  <p>FGT 12 X2</p>		
--	---	--	--

--	--	--	--

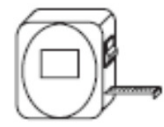
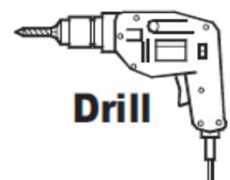
<p>TOOLS REQUIRED</p>	<p>WRENCH/RATCHET 9/16"</p> 	<p>TAPE MEASURE</p> 	<p>Drill</p>  <p>13/32" DRILL BIT</p>
------------------------------	---	---	---

- 1** TO INSTALL TOOL BOX IN TRUCK BED:
Peel the backing covering the adhesive on the gasket [H].
Apply the gasket to the underside of the tool box.

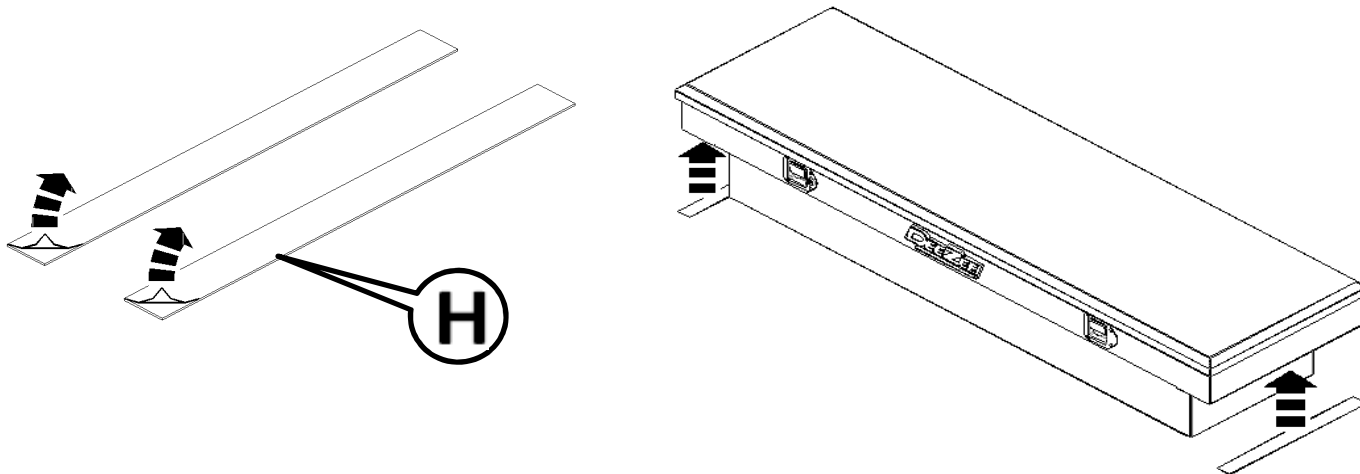

- 2** Place the tool box in the truck and center it on the vehicle. Use a tape measure to check center.
Open the lid to make sure there is sufficient clearance for the cab.

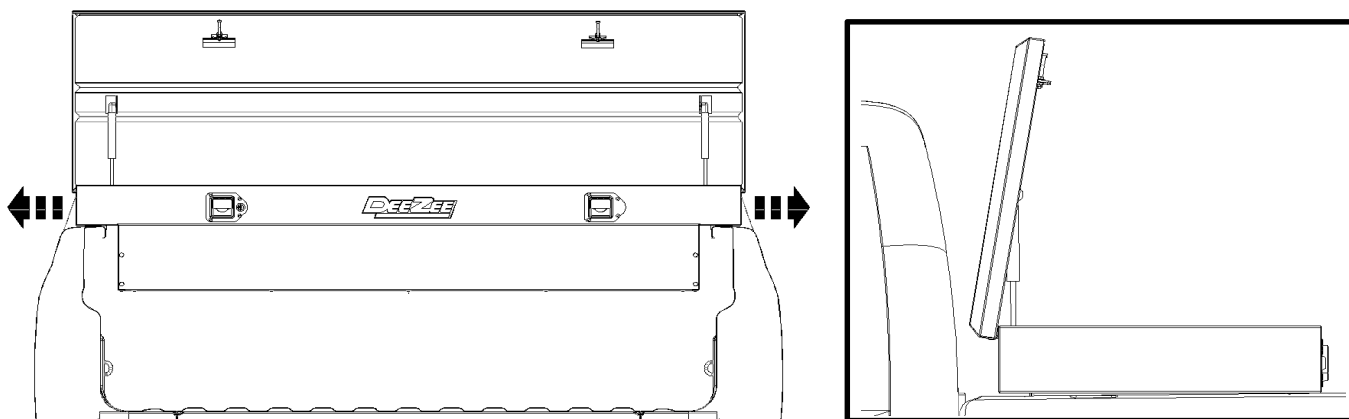

3

Once the tool box is centered, mark and drill the mounting hole for the J-hook.
The mounting hole should be near the center of the box, and near the lip of the truck bed rail

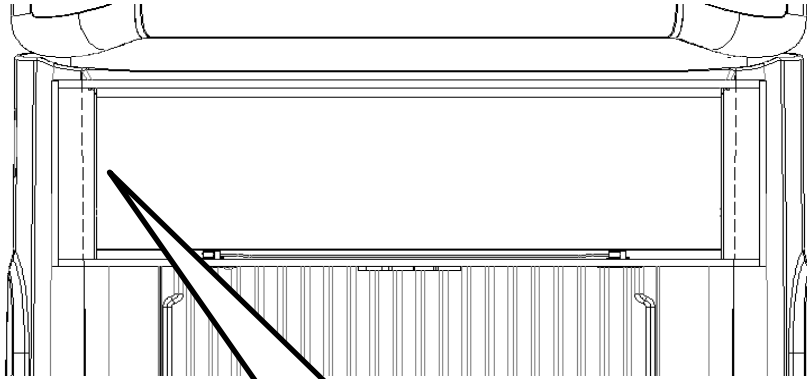

TOP VIEW OF TOOL BOX BODY IN TRUCK BED

LIP OF TRUCK BED RAIL UNDER TOOL BOX



HOLE FOR J-BOLT SHOULD BE IN THIS AREA

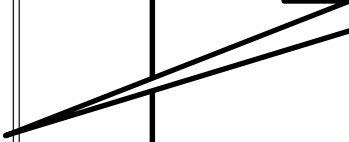

Note: After you have marked the location to drill, slide the tool box towards the side you are not drilling to make sure you don't hit the bedrail with the drill bit.

Drill a 13/32" hole on each end of the tool box.
Be sure to drill between the edge of the tool box and the bed rail.

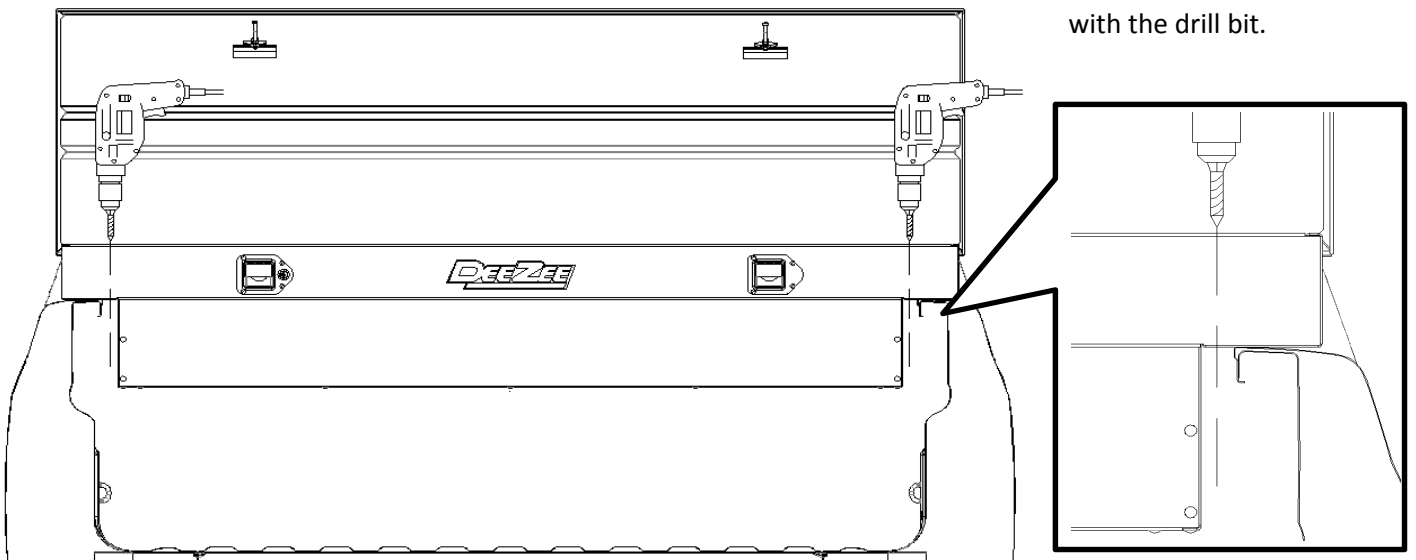

4 Once the holes are drilled, attach the tool box using the J-bolt [C], 3/8" washer [E], 3/8" lock washer [F], and 3/8" nut [D]. Use a 9/16" deep well socket, or a 9/16" wrench to tighten.

Once the tool box is secured, place the vinyl cap [G] on the exposed J-bolt threads.

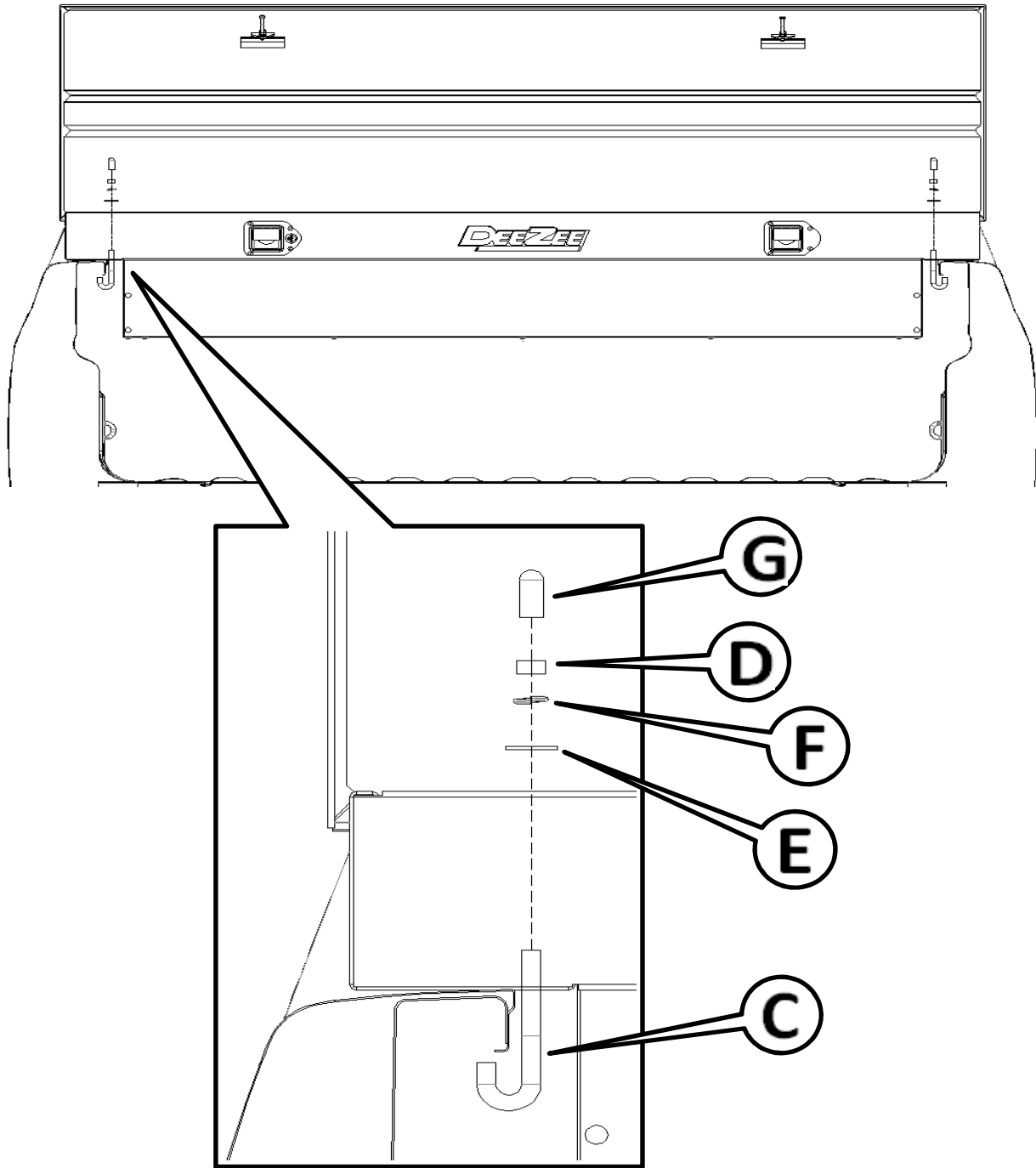

MAINTENANCE INSTRUCTIONS:

All locks, latches, latching rods, and hinges should be lubricated periodically to assure smooth and proper operation for the life of the tool box.

TOOL BOX LATCH ADJUSTMENT

NOTE: TOOL BOX LATCH WAS PRESET AT THE FACTORY. MAKE SURE THE LATCH IS ADJUSTED TO THAT OF YOUR DESIRED SEAL.

ALSO, PERIODIC ADJUSTMENT MAY BE NEEDED OVER TIME.

PLEASE REFER TO LATCH ADJUSTMENT INSTRUCTION BELOW.

- 1) Keeping the striker plate perpendicular to the lid, adjust the striker location left and right to align the pin with the latch as shown below. The dot identified by the arrow shows the preferred location of the striker pin.

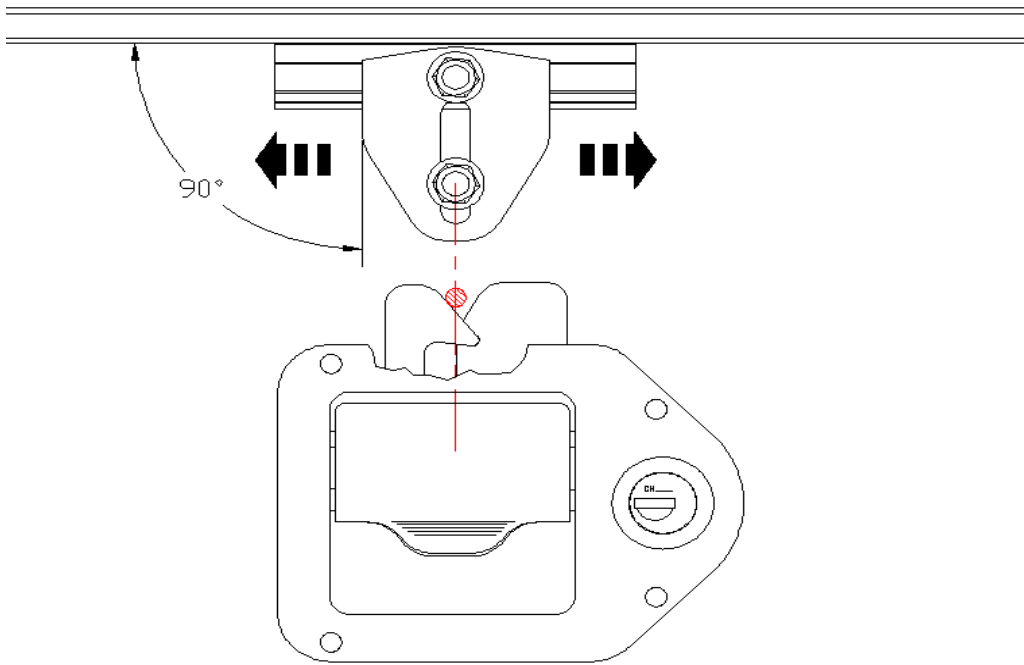

- 2) When the striker pin is correctly centered, tighten top bolt to set the location.

3) Set the pin depth to ensure that the head will clear the latch.

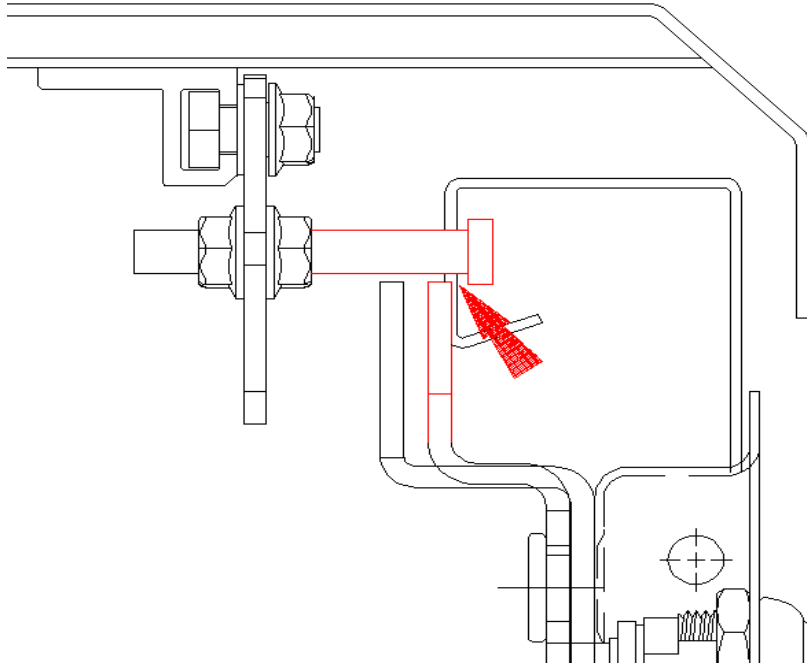

4) Tighten the pin in the lowest location, and close the lid. If the lid is able to move up and down when latched, the latch pin needs adjusted. Adjust the pin up the approximate amount the lid is able to move and retighten. Repeat as necessary.

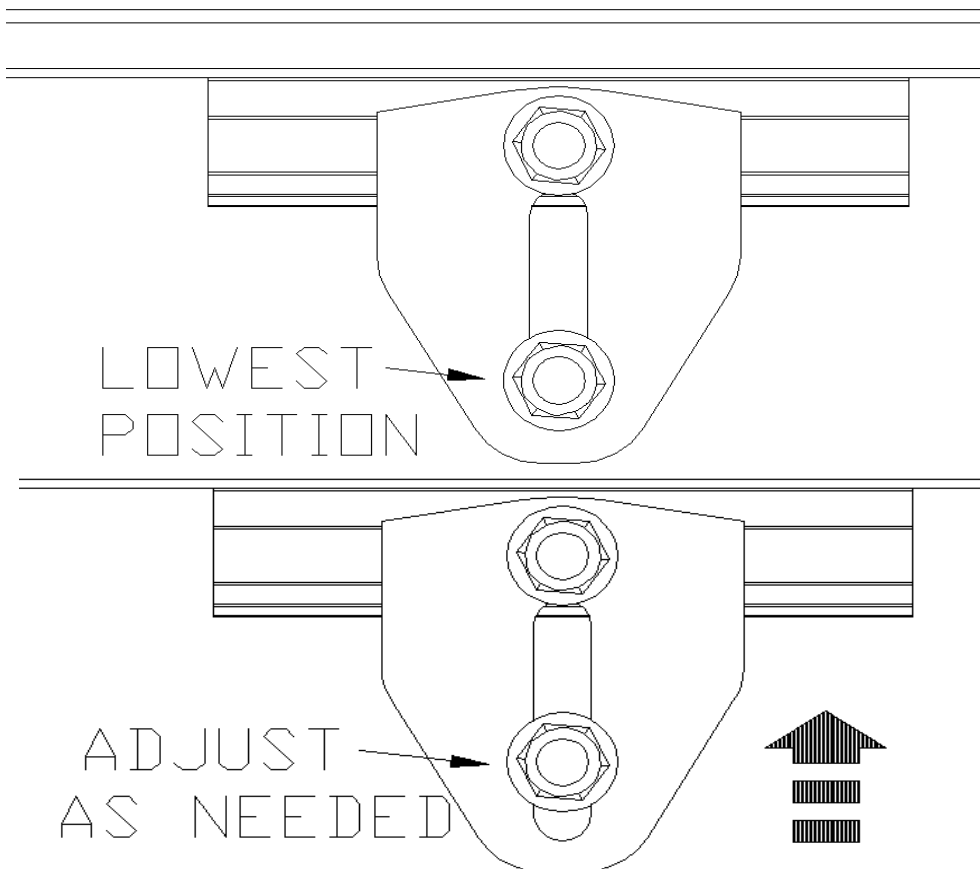













Illustration	Description	Illustration	Description
 DZTBTRAY1	Tool Box Tray (Plastic) 18" x 15.5"	 K2702STC	T - Handle Latch Steel Underbed Tool Boxes Only {Keys Included}
 DZTBTRAYHD	Tool Box Tray (Steel) 18" x 15.5"	 K2702ST	T - Handle Latch Aluminum Underbed Tool Boxes Only (Keys Included)
 DZTBMAT2	Tool Box Mat 72" x 20"	 TB85623	Blue Label Push Button Latch (Keys Included)
 DZTBLATCH1	Locking Hook Style Latch (Keys Included)	 TB85619N	Red Plus Push Button Latch (Driver Side, Keys Included)
 DZTBLATCH2	Non-Locking Hook Style Latch	 TB85621N	Red Plus Push Button Latch (Passenger Side, Keys Included)
 DZTBLATCH3	Locking Post Style Latch (Keys Included)	 TB85620N	Tool Box Push Button Post Piece
 TB85614N	Non-Locking Post Style Latch	 DZTBLOCK1	Lock Cylinder - Straight Tab (Keys Included)

Illustration	Description	Illustration	Description
 DZTBSHOCK1	Ball and Socket Mounted Shock 10.5" 80lb.	 BPTBOX1	Standard Tool Box Mounting Kit
 DZTBSHOCK2	Blade and Eyelet Mounted Shock 10" 70lb.	 DZ97904	Premium Tool Box Mounting Kit
 DZTBSHOCK3	Shock - ball and socket mount 10.5" 60lb	 DZGASCAP	Vented Gas Cap + Threaded Neck
 DZTBSTRIKER	Striker for Post Style Latches	 DZGASCAP2	Vented Gas Cap Only
 B1601ASSM	Red Label Striker	 DZGASCAP3	Lockable Vented Gas Cap With Threaded Neck
 B1876ASSM	Blue Label Striker	 PLG01	Plastic Plugs (2)
 PS1000	Adjustable Striker for Lift-up Paddle Handle Tool Boxes	 FGT12	Foam Grip Tape (2) 22" x 1.5"
 TB85615	Latch Rod Connector	 FGT02	Foam Grip Tape (15' Roll)