

# JL Rear Door Workbench Installation Instructions

## DZ 4469JL Jeep Wrangler JL 2019-Current

<b>A</b> Rear Door Workbench  JLWB001ASSM X1	<b>B</b> 1 1/4" Spacer  PN 1324 X2	<b>C</b> M6 X 50mm Button Head Bolt  PN 1284 X2
<b>D</b> M6 Washer  PN 645B X2	<b>E</b> 3M Double Sided Tape  TAPE-25 X1	

### Required tools

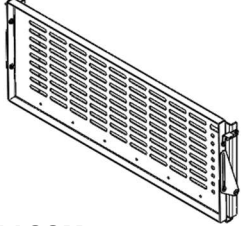
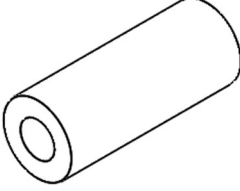
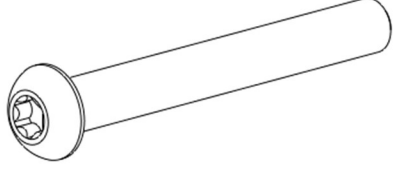
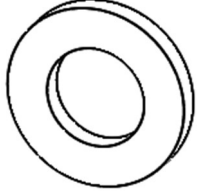
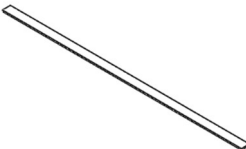
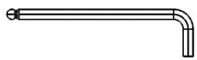

Allen Wrench  
4mm



Drill  
1/2"

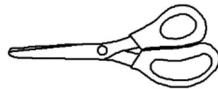

Scissors



Straight Blade  
Screwdriver

**1** First cut the piece of double sided tape (E) in half making 2 pieces total

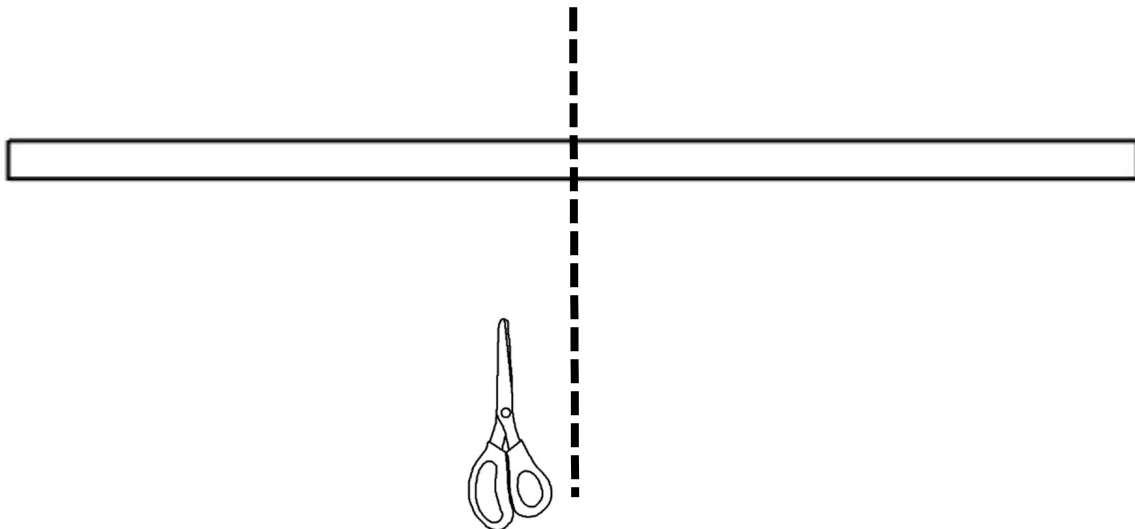

**2**

Remove top cover on rear door by prying it off using a screwdriver.



**3**

Use 1/2" drill bit to drill holes using guides in the locations shown below.



**DZ 4469JL**

**4**

Reinstall plastic to cover and install spacers (B) into the holes drilled from the previous step.



**5**

Place tape from step 1 onto the lower area on the rear of the brackets as shown.

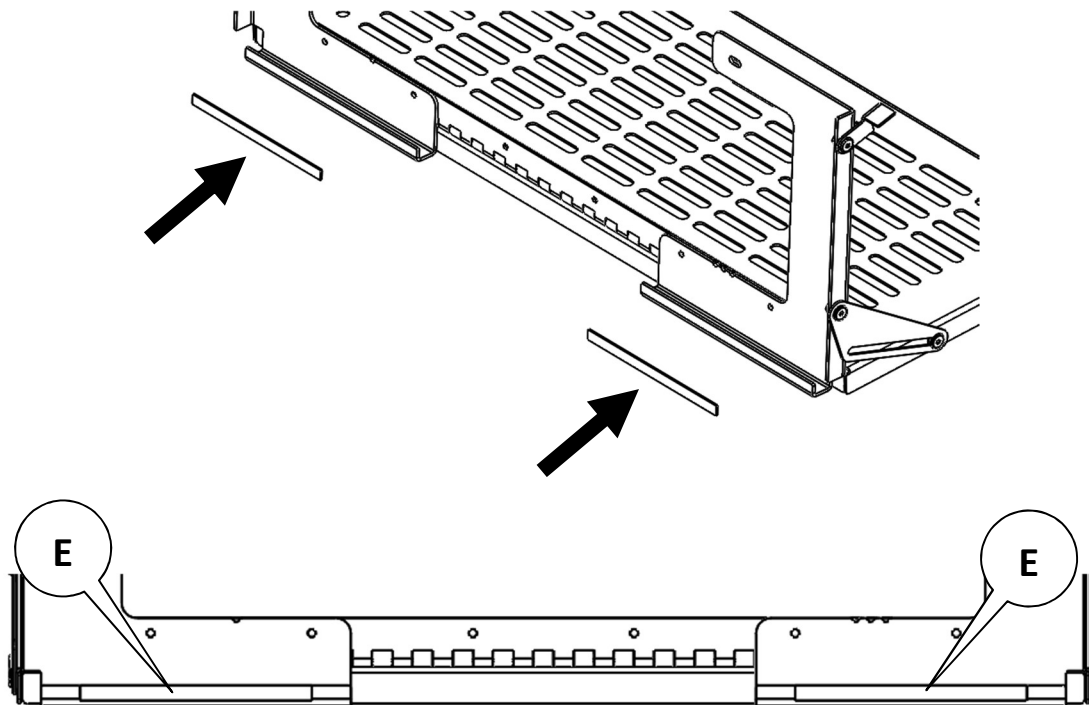

6

Peel back one corner of the double sided tape towards the bottom side of the workbench. Then install workbench using bolts (C) and washers (D) through the spacers installed previously. Fully tighten hardware at this time. Peel off the rest of the double sided tape cover and press against the rear door. Tighten or loosen any hardware to desired tension of hinge and latches.

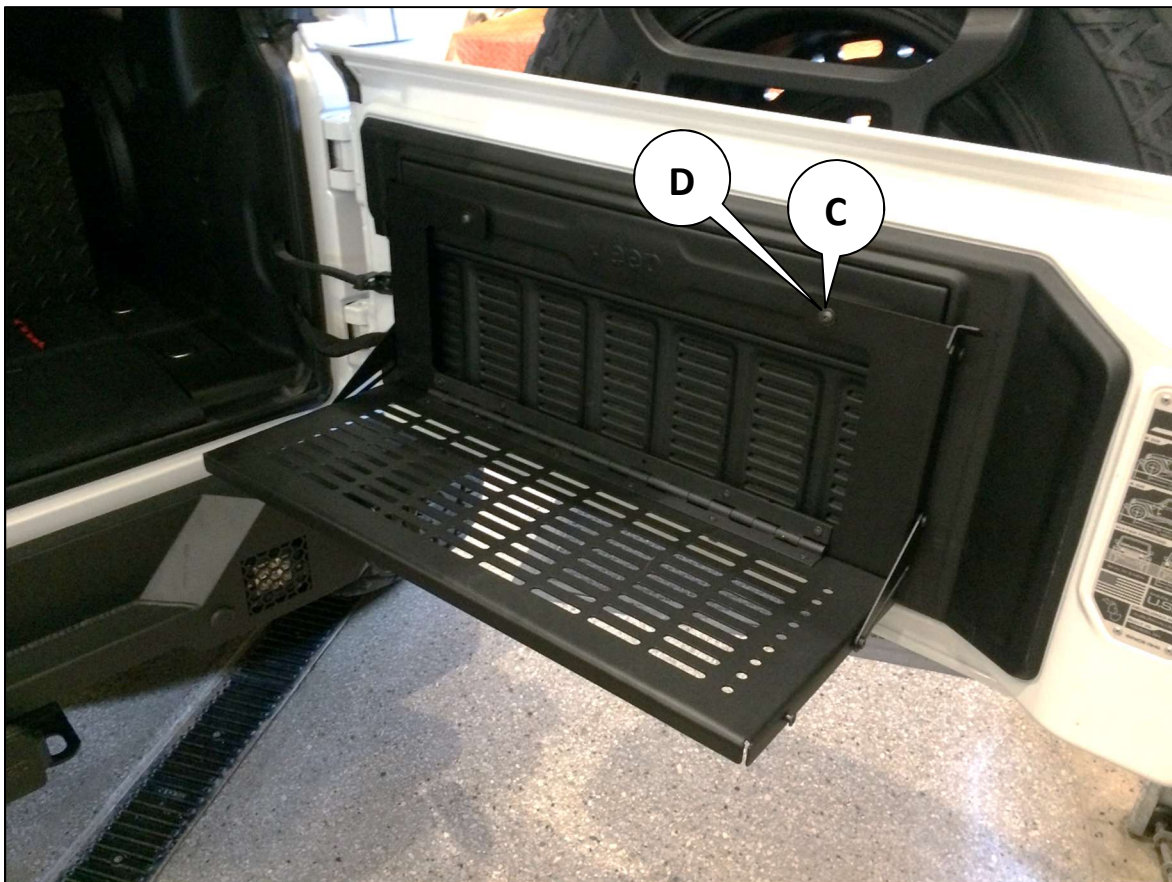

[View other car organizers made by Dee Zee on our website.](#)