



**INSPECT YOUR PRODUCT FOR DAMAGE & MISSING
PARTS BEFORE PROCEEDING TO INSTALLATION**

PROCEDURE FOR RETURNS OR MISSING HARDWARE

-PLEASE CONTACT THE ORIGINAL POINT OF PURCHASE FOR:
SHIPPING DAMAGE, RETURNS, OR WARRANTY CLAIMS

-CONTACT DEE ZEE DIRECTLY FOR MISSING PARTS OR HARDWARE

⚠ WARNING: Cancer and Reproductive Harm

Operating, servicing, and maintaining a passenger vehicle can expose you to chemicals such as lead, phthalates, engine exhaust, and carbon monoxide that are known to the State of California cause cancer and birth defects or other reproductive harm. To minimize exposure, service your vehicle and its accessories in a well-vented area and wear gloves or wash your hands frequently.



Thank you for choosing Dee Zee to add function and accessorize your vehicle. Dee Zee has been a staple brand in the truck accessory market since 1977 and we hold a reputation of quality manufacturing based in America's Heartland. Our products are born through careful engineering and backed by industry leading warranty programs. We appreciate the opportunity to serve you and your vehicle!

Review the instruction pages in their entirety to prepare the required tools

Warning: Please check for wiring or other obstructions before drilling any holes in the vehicle. If it is necessary to drill any holes, Dee Zee recommends putting a sealant or rust inhibitory around all holes drilled into the body of the vehicle.

It is the sole responsibility of the vehicle owner to check for tire clearance. It is unlawful and dangerous to ride on any external vehicle step while the vehicle is in motion.







Cleaning: To be entitled to all warranty rights offered with the product, Dee Zee steps need to be cleaned regularly with a mild detergent. Do NOT use abrasive cleaners. For stainless steel products, the application of a high grade automotive wax is recommended.

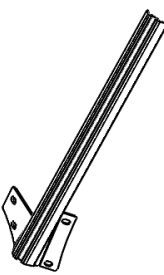

Dee Zee Cares - Please Recycle

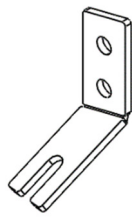
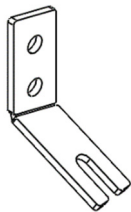
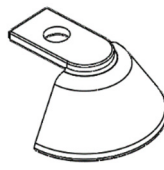
JK A-Pillar Light Bracket Installation Instructions

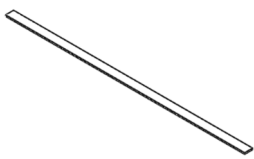
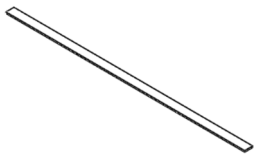
DZ 4446JK Jeep Wrangler JK 2007-2018

<p>A Driver Bracket</p>  <p>B 2584LWP X1</p>	<p>B Passenger Bracket</p>  <p>B 2584RWP X1</p>	<p>C Accessory Mount Bracket</p>  <p>B 2587LP X1</p>
<p>D Accessory Mount Bracket</p>  <p>B 2587RP X1</p>	<p>E Bolt-On Half Hex Endcap</p>  <p>EC DZE-620 X4</p>	<p>F M8 X 12mm Button Head Bolt</p>  <p>PN 1260 X12</p>
<p>G M8 Square Nut</p>  <p>PN 1262 X12</p>	<p>H 3M Double Sided Tape</p>  <p>TAPE-25 X2</p>	<p>I Gasket</p>  <p>FGT 49 X1</p>
<p>J Alcohol Pad</p>  <p>ALPAD X2</p>		

Required tools

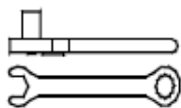

Ratchet / Wrench

Torx 40

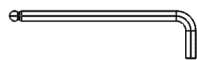

Allen Wrench
5mm



Tape Measure

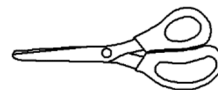

Scissors

- 1** First cut the two pieces of double sided tape (H) in half making 4 pieces total

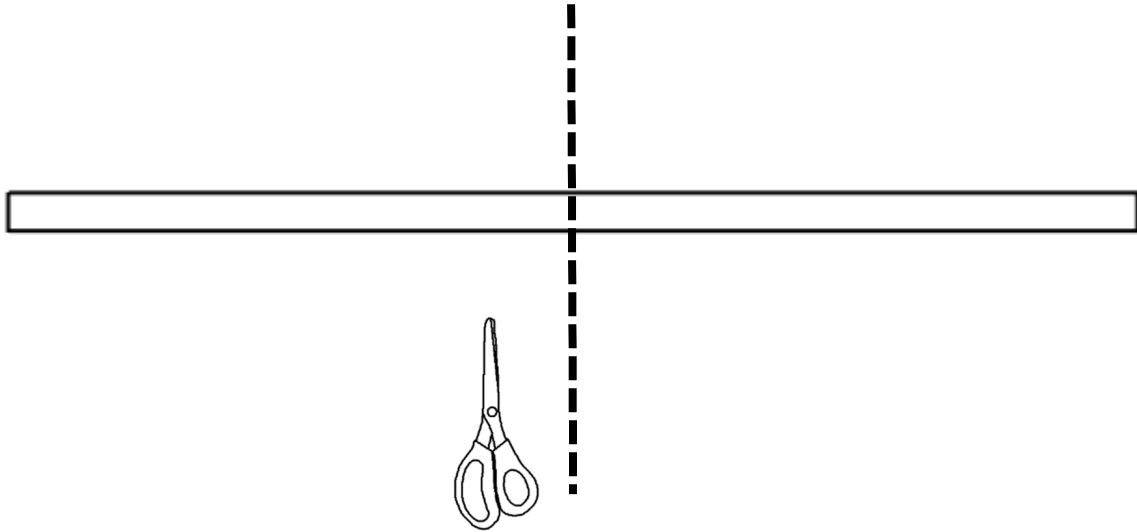

- 2** Measure from the top of the driver bracket (A) 6 inches down and use an alcohol pad (J) to clean off the next 6 inches of the inside surface of the bracket on each side. Then peel off one side to the tape and apply it 6 inches down from the top of the bracket as shown. Repeat on passenger bracket (B) using the same alcohol pad.

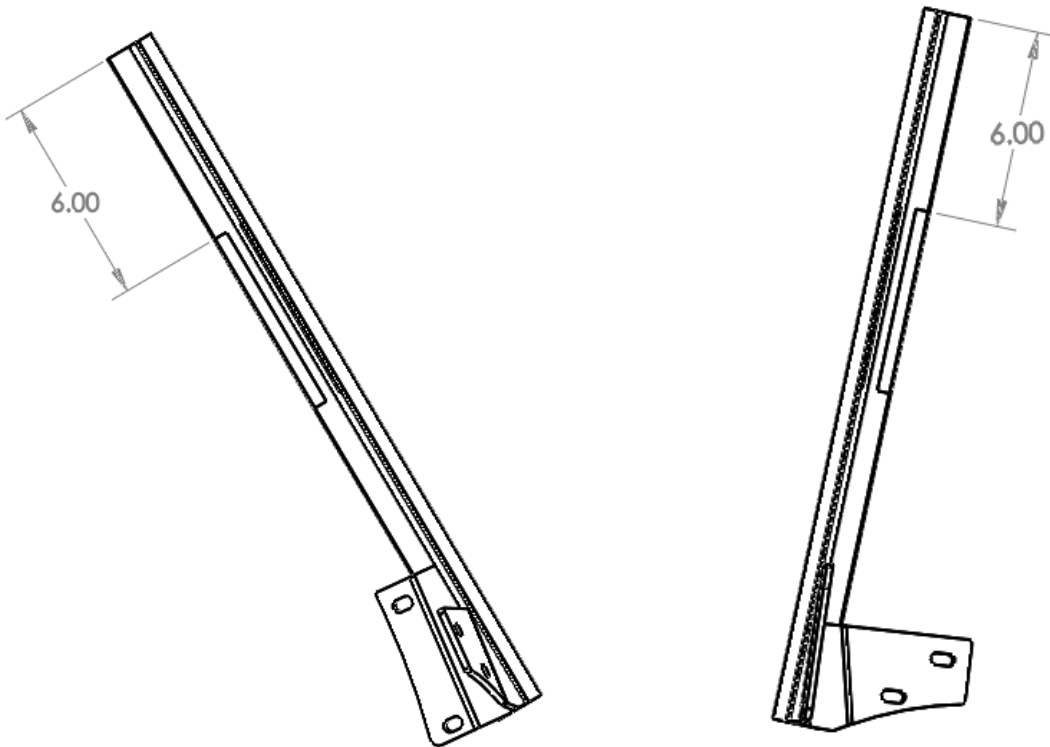

- 3** Cut Gasket (I) into 12 pieces. Lengths are 4 1/2", 4 5/8", 3 5/8", 3 3/8", 1 3/8", 1/2". There will need to be two of each length. Then peel off the backing of the Gasket (I) and place the gasket on the back sides of the Driver side bracket (A) as shown. Tape may need to be notched around the holes. Repeat this step with the passenger bracket.

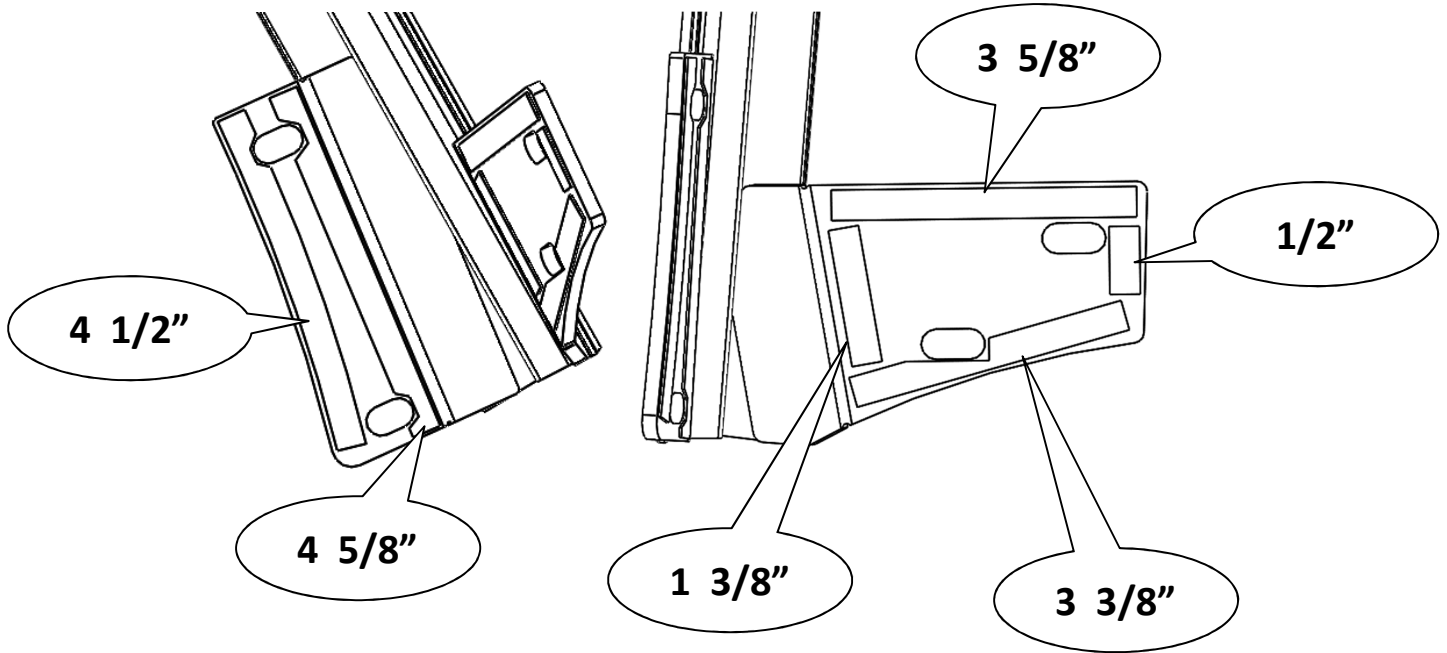

- 4** Peel up one corner of the double sided tape to the outside of the bracket. Then use alcohol pad (J) to clean off the A-pillar on the Jeep in the area shown in the picture below. Repeat this step with the passenger bracket and the passenger side A-pillar.



5

Remove the four bolts that are shown in the picture below. Then install the Driver A-pillar bracket using the factory bolts. Make sure the backing of the double sided tape is showing before tightening the bolts.

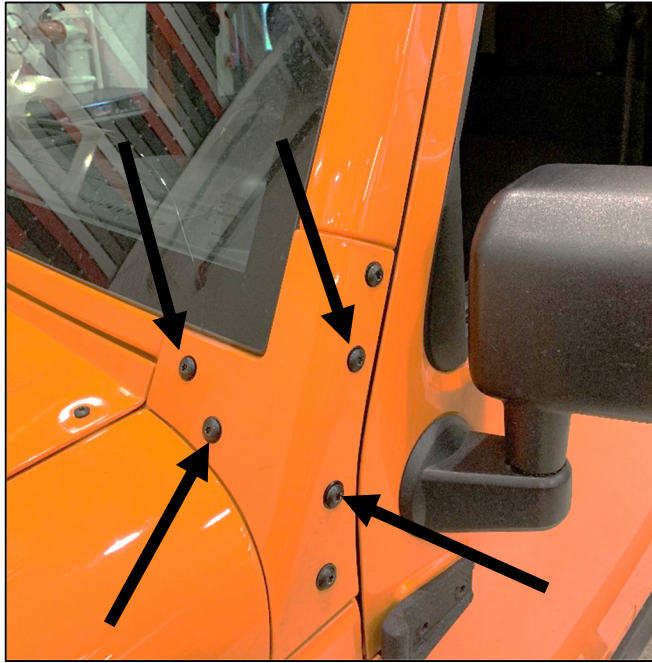

6

Remove the backing of the tape and push the bracket against the vehicle.

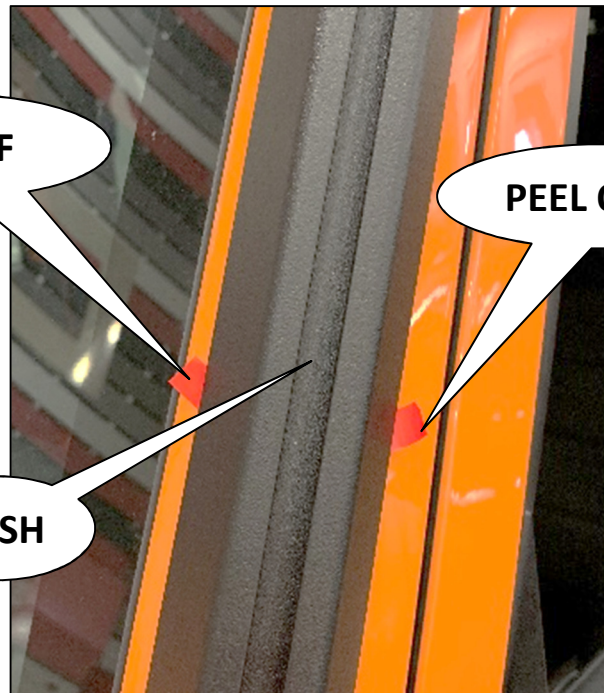

7

Mounting the accessory mount bracket (C) is optional. If you want to mount the accessory mount bracket install bolt (F) through the bracket and put a nut (G) on the back side and slide the bracket in the channel and locate the desired position. Fully tighten bracket.

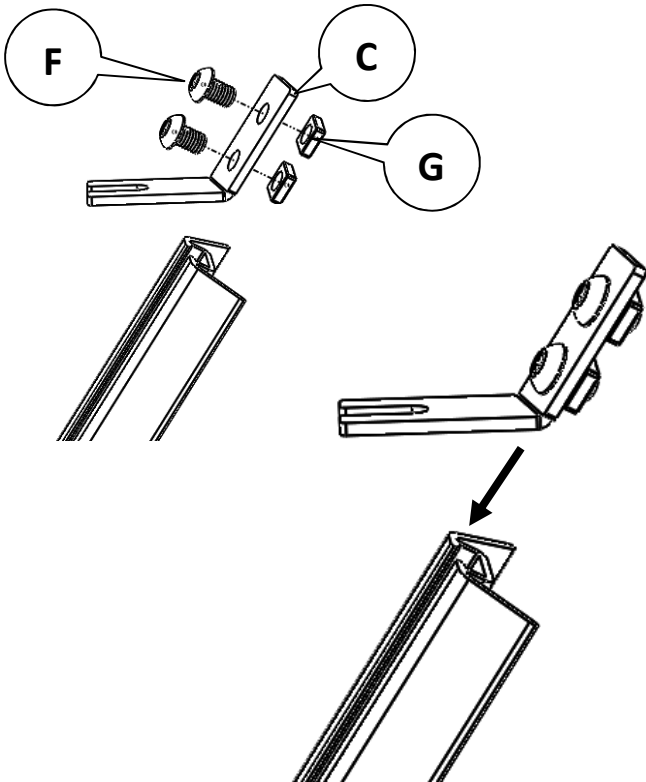

When A-Pillar bracket is mounted the windshield will not be able to be folded down. Brackets C and D are not intended for a Light Bar.

8

Install bolt (F) through the endcap (E) and install nut (G) on the other side. Slide nut into channel until the endcap is flush with the top of the bracket and Fully tighten hardware. Repeat this step on the bottom side of the Bracket.

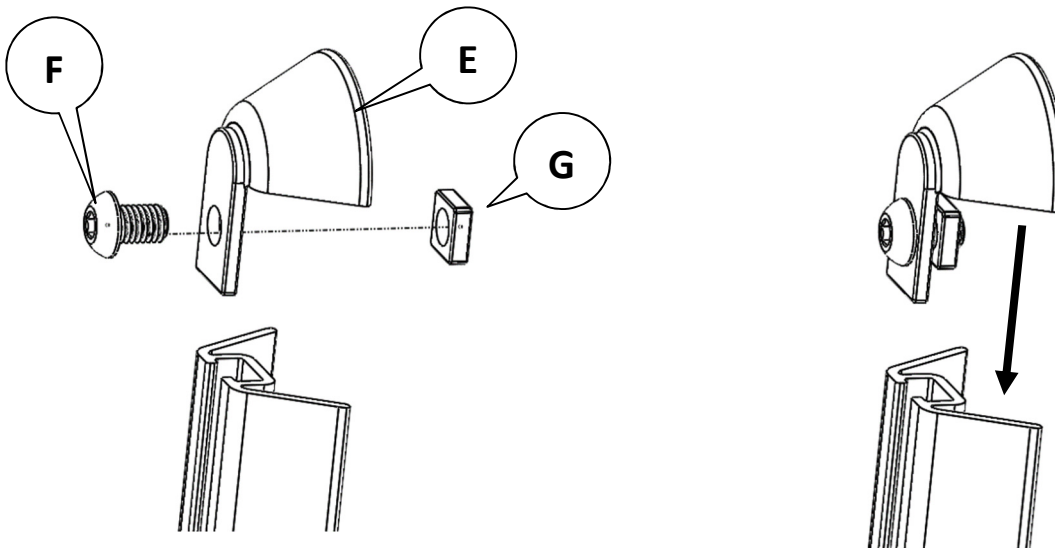

Repeat Steps 5-8 on Passenger side Using bracket B instead of A.