



Thank you for choosing Dee Zee to add function and accessorize your vehicle. Dee Zee has been a staple brand in the truck accessory market since 1977 and we hold a reputation of quality manufacturing based in America's Heartland. Our products are born through careful engineering and backed by industry leading warranty programs. We appreciate the opportunity to serve you and your vehicle!

Review the instruction pages in their entirety to prepare the required tools

Warning: Please check for wiring or other obstructions before drilling any holes in the vehicle. If it is necessary to drill any holes, Dee Zee recommends putting a sealant or rust inhibitory around all holes drilled into the body of the vehicle.

It is the sole responsibility of the vehicle owner to check for tire clearance. It is unlawful and dangerous to ride on any external vehicle step while the vehicle is in motion.

Cleaning: To be entitled to all warranty rights offered with the product, Dee Zee steps need to be cleaned regularly with a mild detergent. Do NOT use abrasive cleaners. For stainless steel products, the application of a high grade automotive wax is recommended.

⚠️ WARNING: Cancer and Reproductive Harm

Operating, servicing, and maintaining a passenger vehicle can expose you to chemicals such as lead, phthalates, engine exhaust, and carbon monoxide that are known to the State of California cause cancer and birth defects or other reproductive harm. To minimize exposure, service your vehicle and its accessories in a well-vented area and wear gloves or wash your hands frequently.



Dee Zee Cares - Please Recycle

PARTS LIST:

1	Driver/left side 3" Oval Bent End Sidebar	1	Passenger/right Rear Mounting Bracket
1	Passenger/right side 3" Oval Bent End Sidebar	4	1/2" x 2" Hex Bolts
1	Driver/left Front Mounting Bracket	4	1/2" Lock Washers
1	Passenger/right Front Mounting Bracket	4	1/2" x 1-1/2" OD x 1/8" Large Flat Washers
2	Center Support Brackets	2	8-1.25mm x 25mm Combo Bolts
1	Driver/left Rear Mounting Bracket		

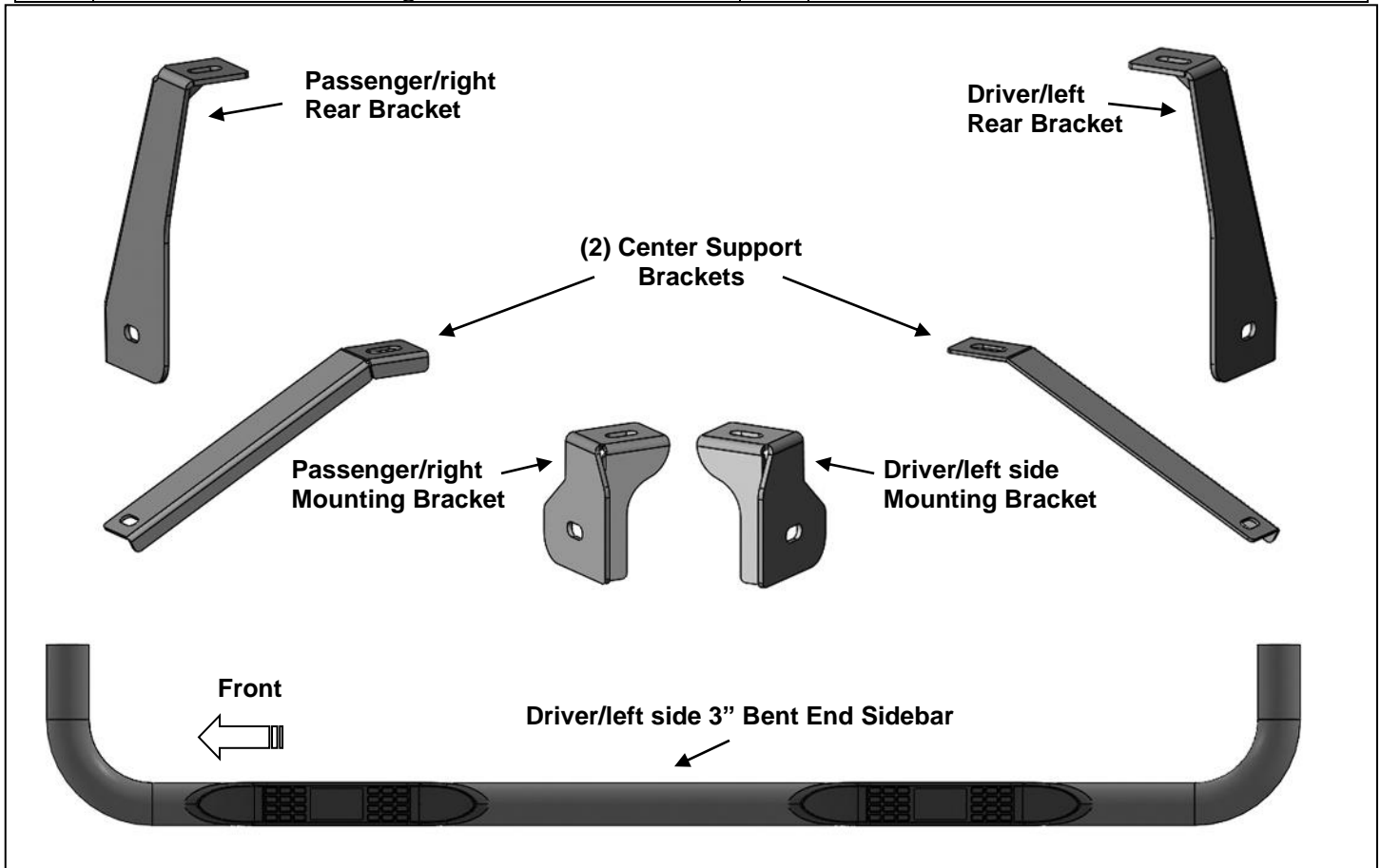

PROCEDURE:

REMOVE CONTENTS FROM BOX. VERIFY ALL PARTS ARE PRESENT. READ INSTRUCTIONS CAREFULLY BEFORE STARTING INSTALLATION. ASSISTANCE IS RECOMMENDED.

1. Start the installation under the driver/left side of the vehicle. Locate the front body mount, **(Figure 1)**. Remove the front body bolt.
2. Select the Driver/left side Front Bracket, **(Figure 2)**. Line up the upper slot on the Bracket with the body bolt hole. Reuse the factory body bolt to attach the Bracket to the top of the body mount, **(Figure 2)**.
3. Move to the center mounting location, **(Figure 3)**. Repeat **Steps 1 & 2** to install (1) Center Support Bracket to the center body mount, **(Figure 4)**.
4. Move to the rear mounting location, **(Figure 5)**. Repeat **Steps 1 & 2** to install the Rear Mounting Bracket to the rear body mount, **(Figure 6)**.
5. Carefully unwrap and select the Driver/left Sidebar. Use the illustration above to help identify the correct Sidebar. With assistance, line up the front end of the tube with the front Bracket slot, **(Figure 7)**. Use (1) 1/2" Hex Bolt, (1) 1/2" Lock Washer and (1) 1/2" Flat Washer to attach

the front end of the Sidebar tube to the Front Bracket, **(Figure 8)**. Snug but do not tighten hardware at this time.

6. Attach the Sidebar to the Center Support Bracket using (1) 8mm Combo Bolt, **(Figures 9 & 10)**. Do not tighten hardware at this time.
7. Repeat **Step 5** to attach the rear end of the Sidebar to the Rear Bracket, **(Figures 11 & 12)**.
8. Level and adjust the Sidebar as necessary and fully tighten all hardware.
9. Repeat **Steps 1—8** for Passenger/right Sidebar installation.
10. Do periodic inspections to the installation to make sure that all hardware is secure and tight.

To protect your investment, wax this product after installing. Regular waxing is recommended to add a protective layer over the finish. Do not use any type of polish or wax that may contain abrasives that could damage the finish. Mild soap may be used also to clean the Sidebar.

Driver/left Side Installation Pictured

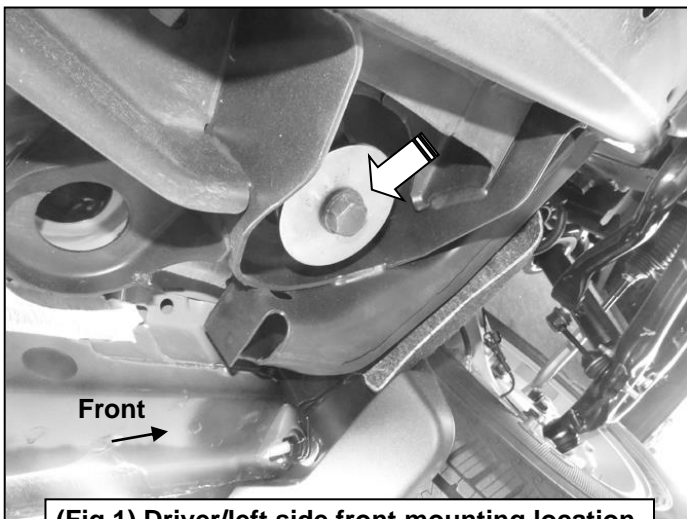

(Fig 1) Driver/left side front mounting location

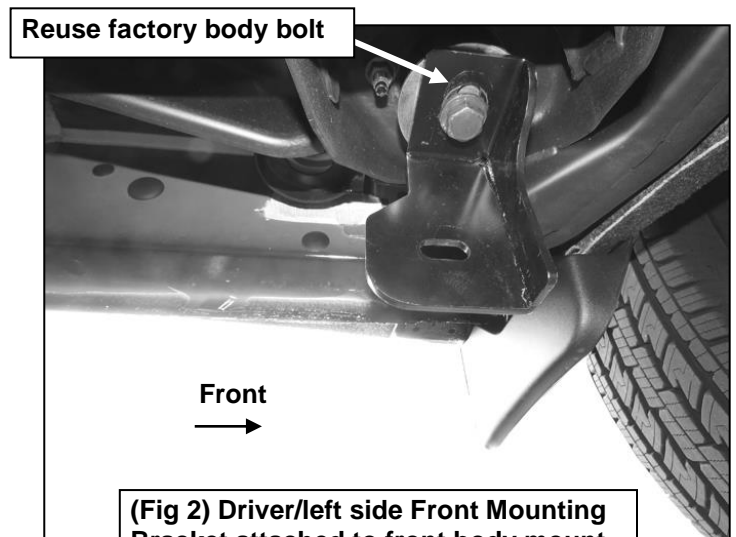

(Fig 2) Driver/left side Front Mounting Bracket attached to front body mount

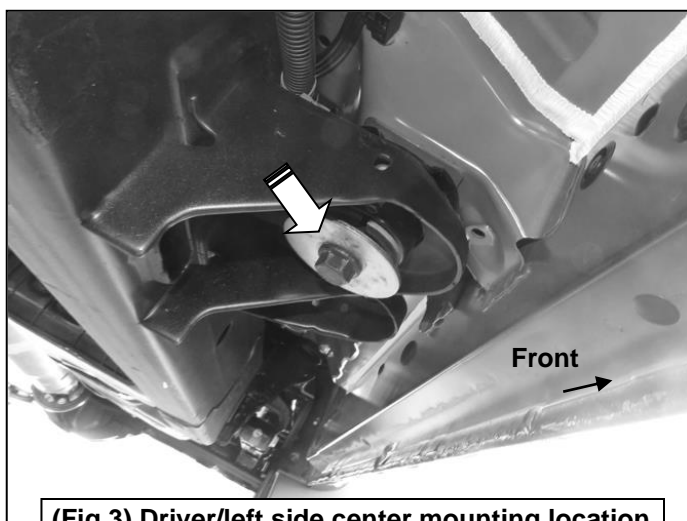

(Fig 3) Driver/left side center mounting location

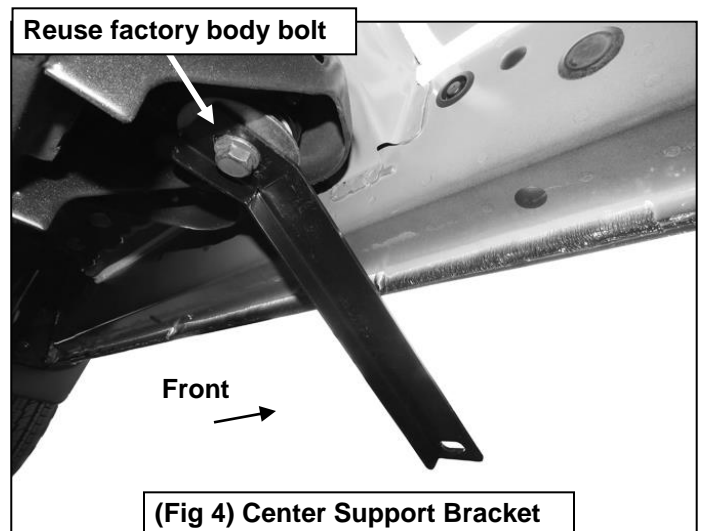

(Fig 4) Center Support Bracket attached to center body mount

Driver/left Side Installation Pictured

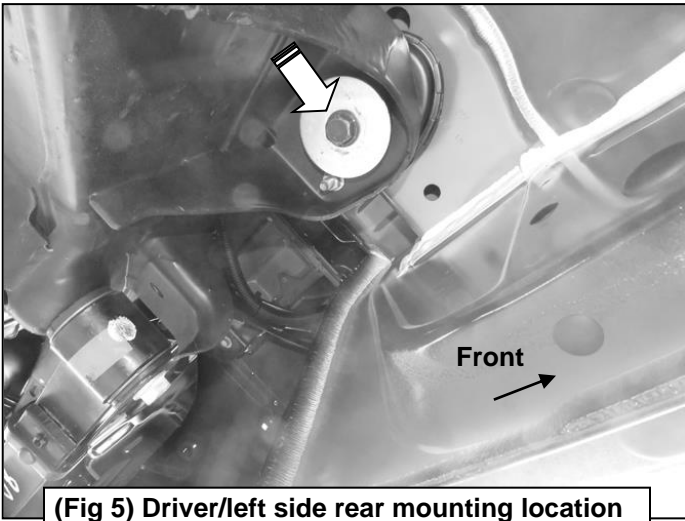

(Fig 5) Driver/left side rear mounting location

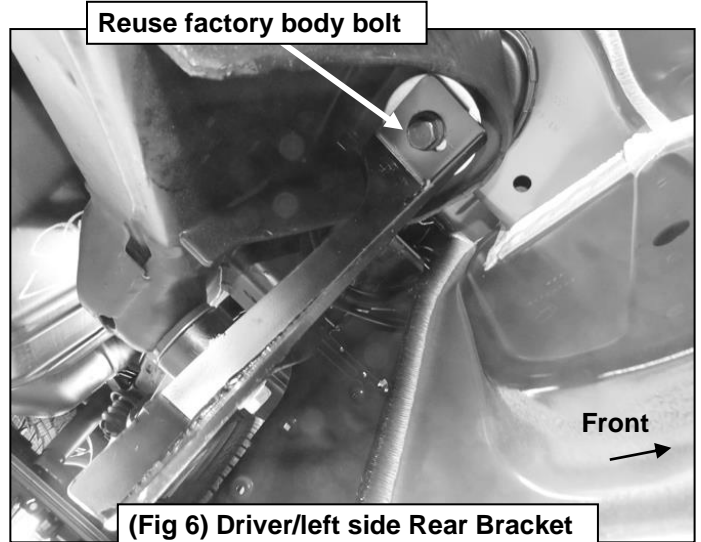

(Fig 6) Driver/left side Rear Bracket attached to the rear body mount

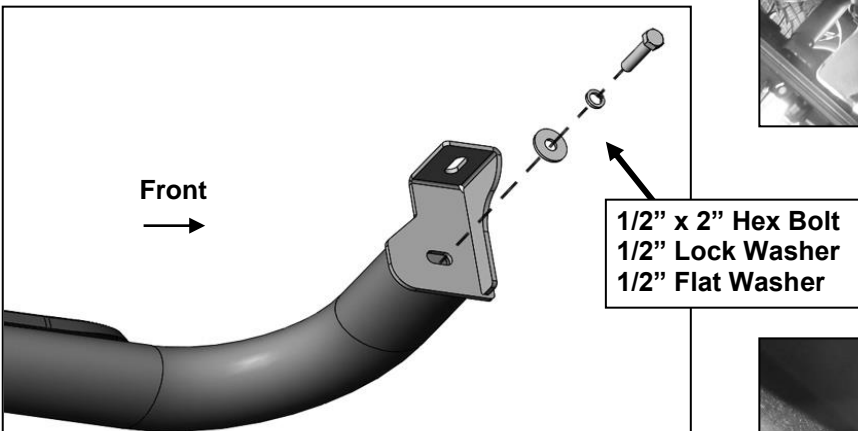

(Fig 7) Driver/left front of Sidebar attached to Front Mounting Bracket illustrated

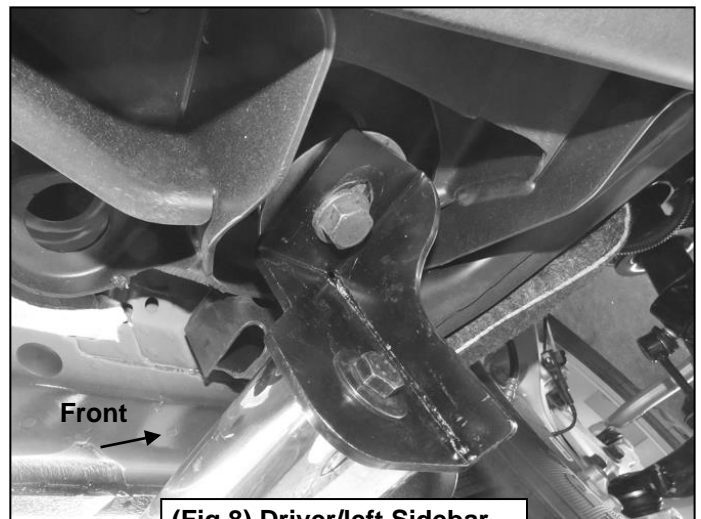

(Fig 8) Driver/left Sidebar attached to Front Bracket

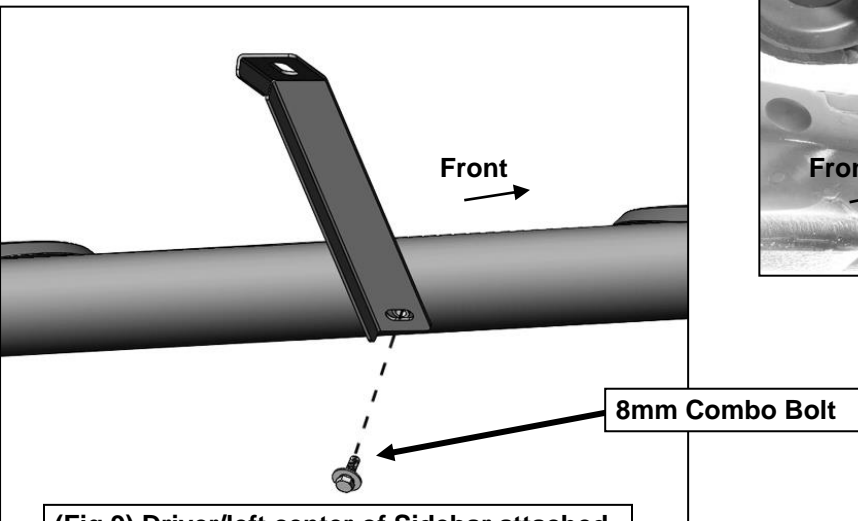

(Fig 9) Driver/left center of Sidebar attached to Center Support Bracket illustrated

Driver/left Side Installation Pictured

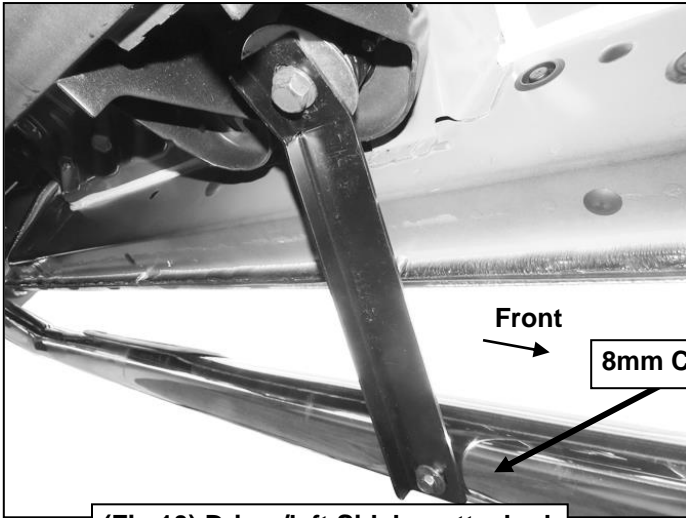

(Fig 10) Driver/left Sidebar attached to Center Support Bracket

8mm Combo Bolt

**1/2" x 2" Hex Bolt
1/2" Lock Washer
1/2" Flat Washer**

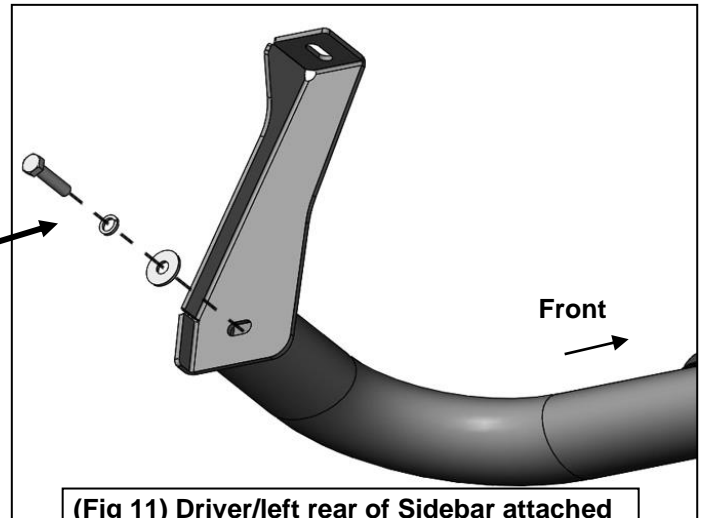

(Fig 11) Driver/left rear of Sidebar attached to the Rear Mounting Bracket illustrated

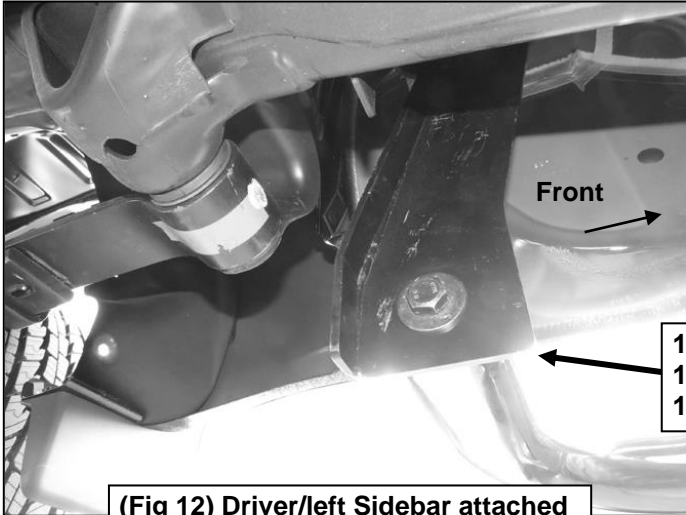

(Fig 12) Driver/left Sidebar attached to the Rear Mounting Bracket

**1/2" x 2" Hex Bolt
1/2" Lock Washer
1/2" Flat Washer**