

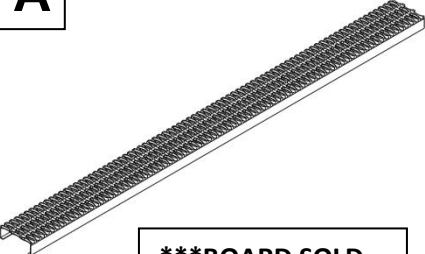
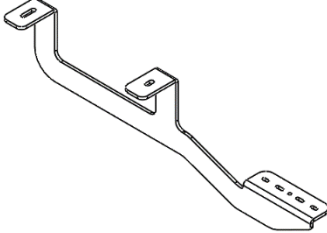
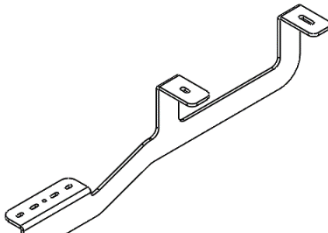
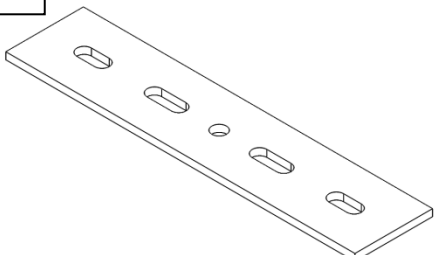
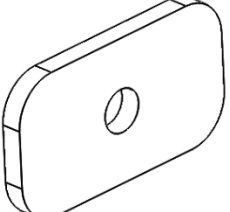
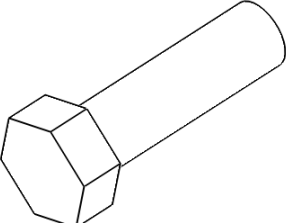
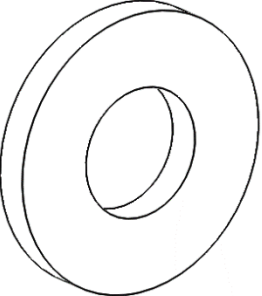
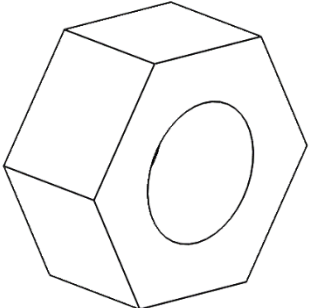
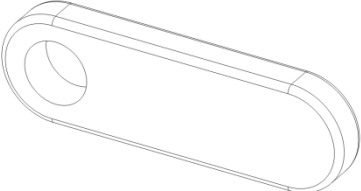
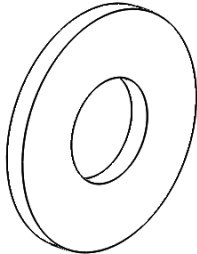
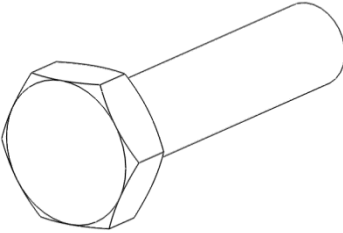
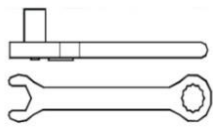

Rear Rough Step Running Board Installation Instructions

DZ 15328R 2013-Current Ford Transit

<p>A Running Board</p>  <p>***BOARD SOLD SEPERATELY</p> <p>Various X1</p>	<p>B Left Bracket</p>  <p>B 2418LP X1</p>	<p>C Right Bracket</p>  <p>B 2418RP X1</p>
<p>D Strap bracket</p>  <p>B 1791P X2</p>	<p>E Large Thread Plate</p>  <p>PN 407 X2</p>	<p>F 3/8-16 X 1 1/4 CD 5 HHCS Zin-Black</p>  <p>PN 114B X4</p>
<p>G 1/4" Washer</p>  <p>PN 72B X12</p>	<p>H 1/4-20 Hex Nut</p>  <p>PN 71B X6</p>	<p>I M10 Threaded Plate</p>  <p>PN 742 X2</p>
<p>J 3/8 Flat Washer</p>  <p>PN 113B X4</p>	<p>K 1/4-20 Hex Cap Bolt</p>  <p>PN 96B X6</p>	<p>Tools Required</p> <p>Ratchet / Wrench 7/16 9/16 15mm</p> 

1

Below are the mounting locations for the rear step brackets on the left side.

Front



Rear



2

Insert the large thread plate (E) into the area shown below in the picture on the left. Then align the hole in the plate with the hole in the frame as shown in the right picture.

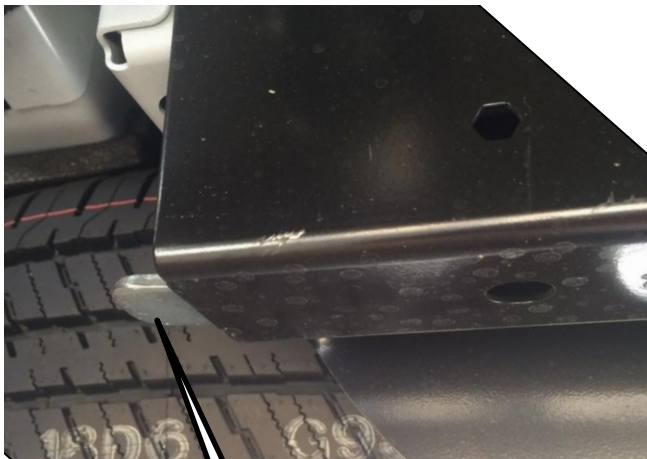

E



- 3** Insert bolt (F) with washer (J) into the left bracket (B) as shown. Then start the M10 thread plate (I) onto the bolt.

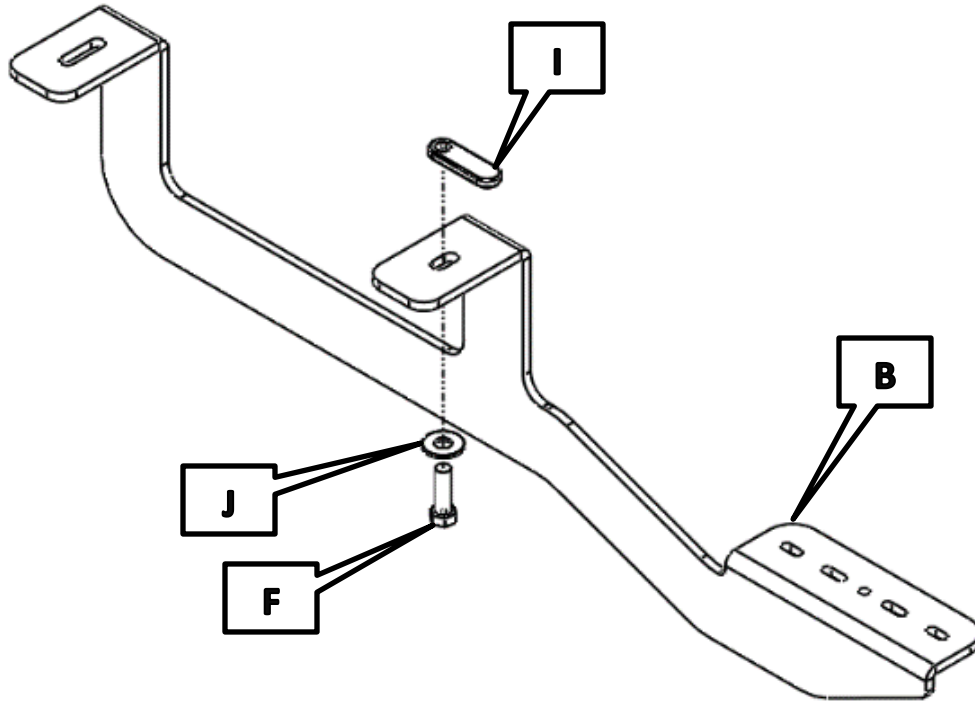

- 4** Insert the M10 thread plate while still attached to the bracket into the rear mounting location of the vehicle. Then align the bracket with the front mounting location.



- 5** Insert bolt (F) and washer (J) into front mounting location. Do not fully tighten at this time.

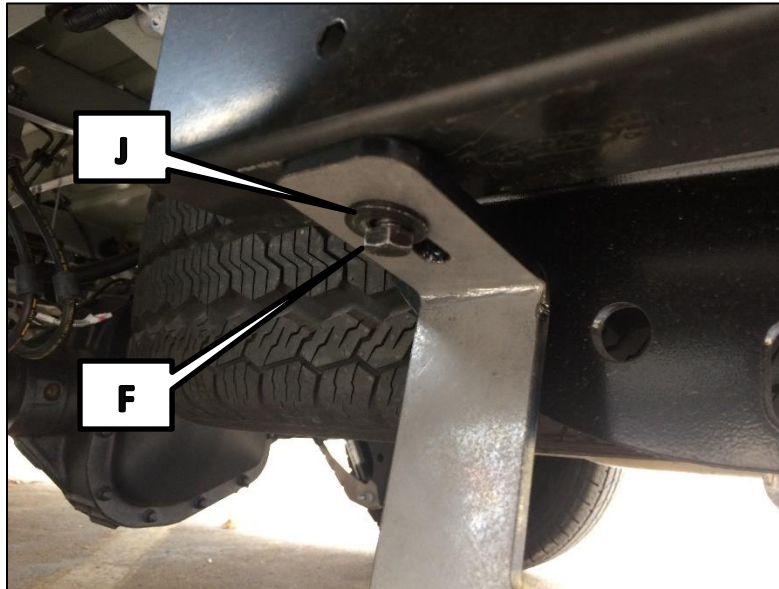

- 6** Repeat steps 1-5 on the right side using the right bracket (C). If your van has a rear tow hook, it will need to be removed.



Remove Bolts



- 7** Place the running board (A) onto the brackets and center the board. Insert a Strap Bracket (D) into the body of the running board on top of each bracket.



- 8** Insert bolts (K) and washers (G) through each strap bracket and both braces. Then install washer (G) and nut (H) on the bottom of the brackets. Fully tighten the board to the braces then tighten the braces to the vehicle.

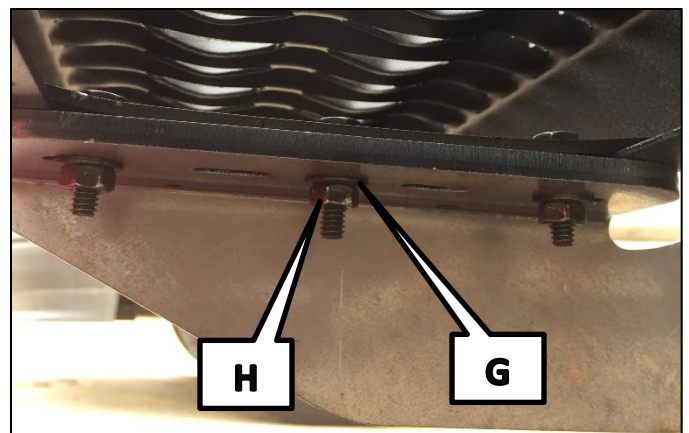
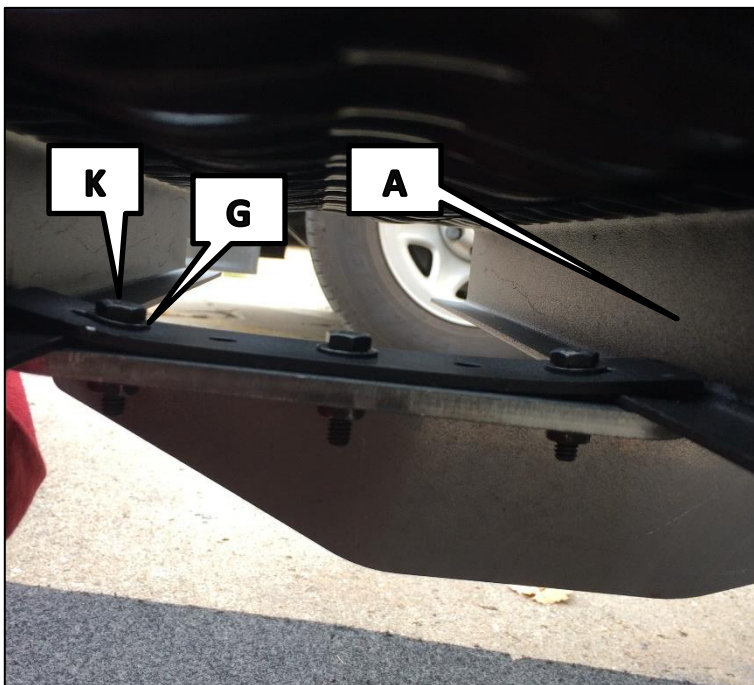

- 9** Slide the pre-assembled end cap into the end of the board (A) until the end cap is flush with the end of the board. The end cap must be inside the board and the strap bracket outside the board. Tighten the bolts with a 7/16" wrench and socket.

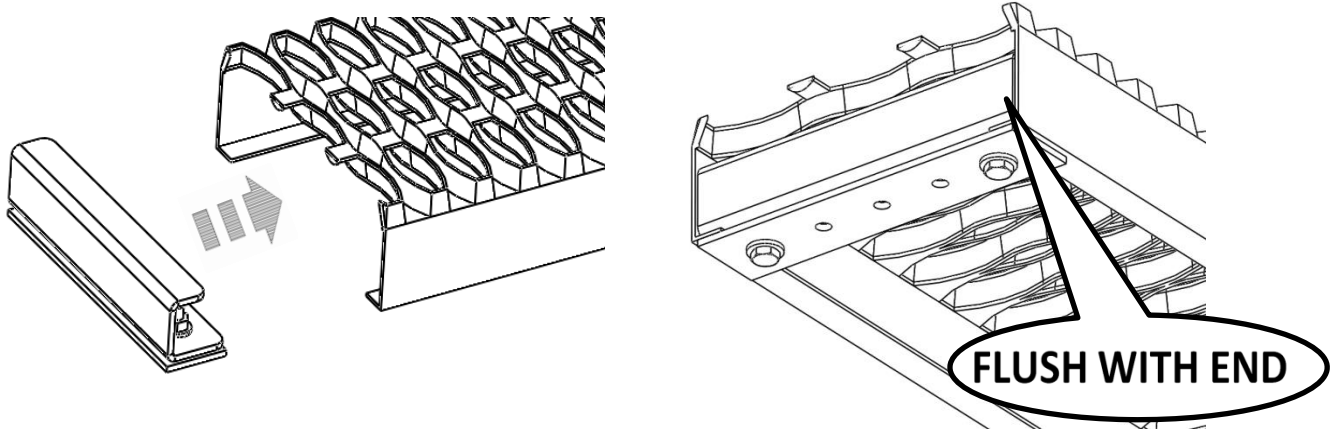

If you do not have the end caps already assembled, refer to the instructions included with the running board.