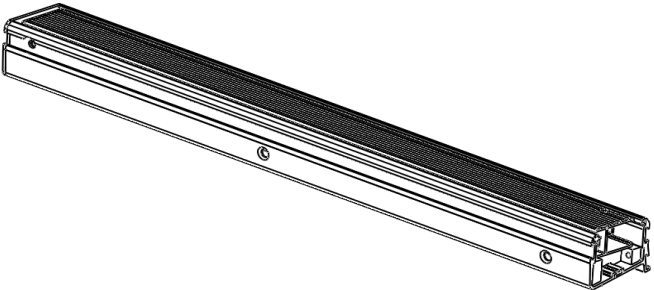
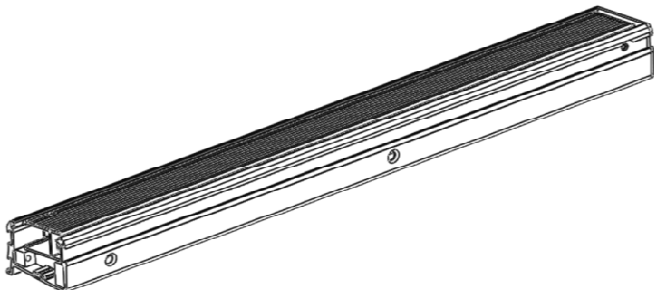
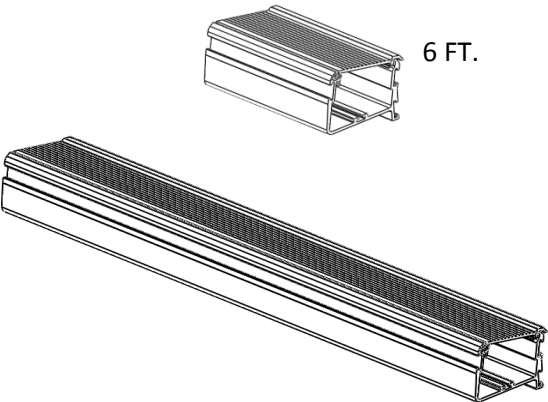
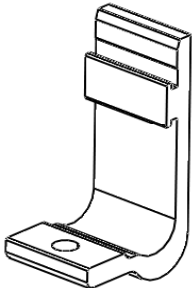
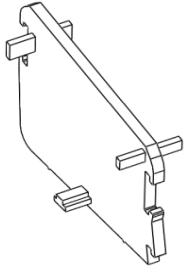
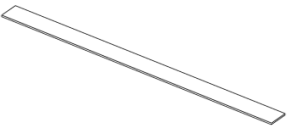
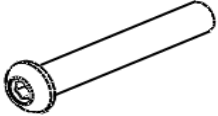
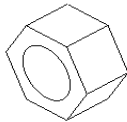

INVIS-A-RACK INSTALLATION INSTRUCTION

DZ 951550, DZ 951600, DZ 951800

<p>A</p> <p style="text-align: center;">DRIVER FRONT / PASSENGER REAR</p> 	<p>B</p> <p style="text-align: center;">PASSENGER FRONT / DRIVER REAR</p> 		
<p>IR-HOUSING-ASSEML</p>	<p>X2</p>	<p>IR-HOUSING-ASSEMR</p>	<p>X2</p>
<p>C</p> <p style="text-align: center;">BUNGEE BOX</p> <p style="text-align: center;">THERE IS NO BUNGEE BOX IN THE 5 FT. APPLICATION</p> 	<p>D</p> <p style="text-align: center;">MOUNTING HOOK</p> 	<p>E</p> <p style="text-align: center;">SECTION CAP</p> 	
<p>VARIES</p>	<p>X2</p>	<p>DZE-539-150CP</p>	<p>X8</p>
<p>F</p> <p style="text-align: center;">FOAM GASKET</p> 	<p>G</p> <p style="text-align: center;">3/8" BOLT</p> 	<p>H</p> <p style="text-align: center;">3/8" NUT</p> 	
<p>FGT 32</p>	<p>16 FT.</p>	<p>PN 220</p>	<p>X8</p>
		<p>PN 90</p>	<p>X8</p>

TOOLS REQUIRED

WRENCH
9/16"

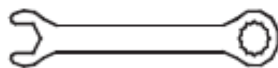

UTILITY KNIFE OR SCISSORS

7/32" ALLEN WRENCH OR SOCKET

RATCHET

- 1 Peel a portion of the paper back from the adhesive on the foam gasket [F].
Apply the sticky side of the gasket to the bottom of the rack assemblies and bungee boxes (if applicable).
Use the lip on the bottom side as a guide to apply the gasket straight with the part.

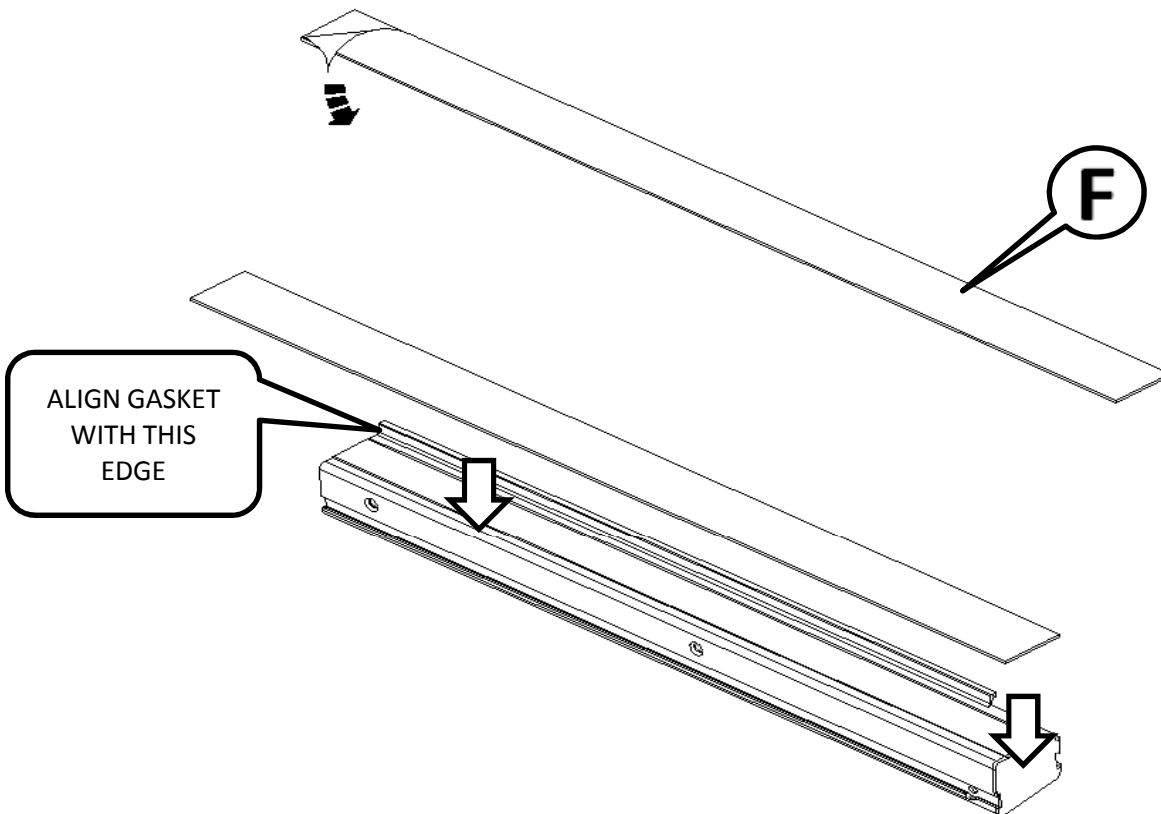

After applying the gasket, use a utility knife to trim the gasket with the end of the part.

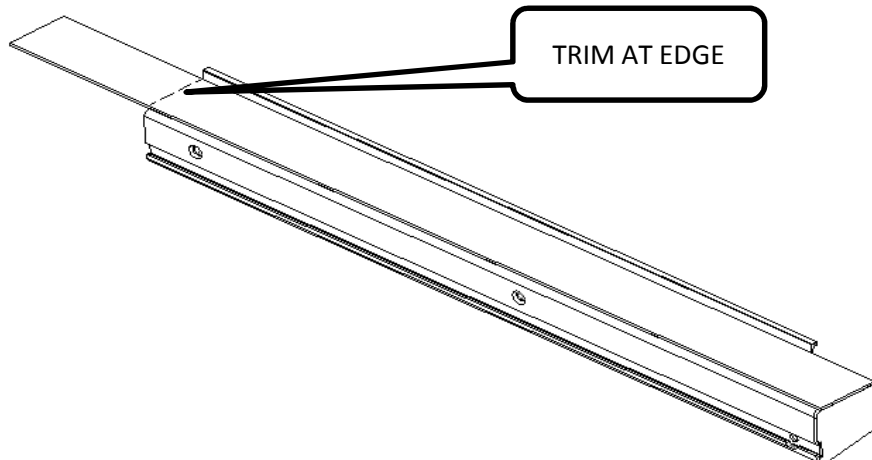

2

If your application includes bungee boxes, they will need to be assembled.

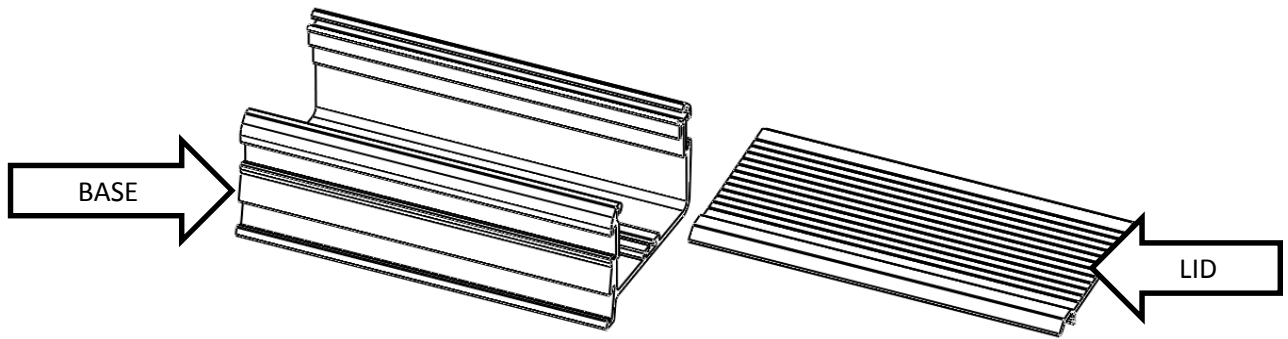

With the lid held almost perpendicular to the base, align the hook on the back of the lid with the channel on the base. Slide the lid onto the base.

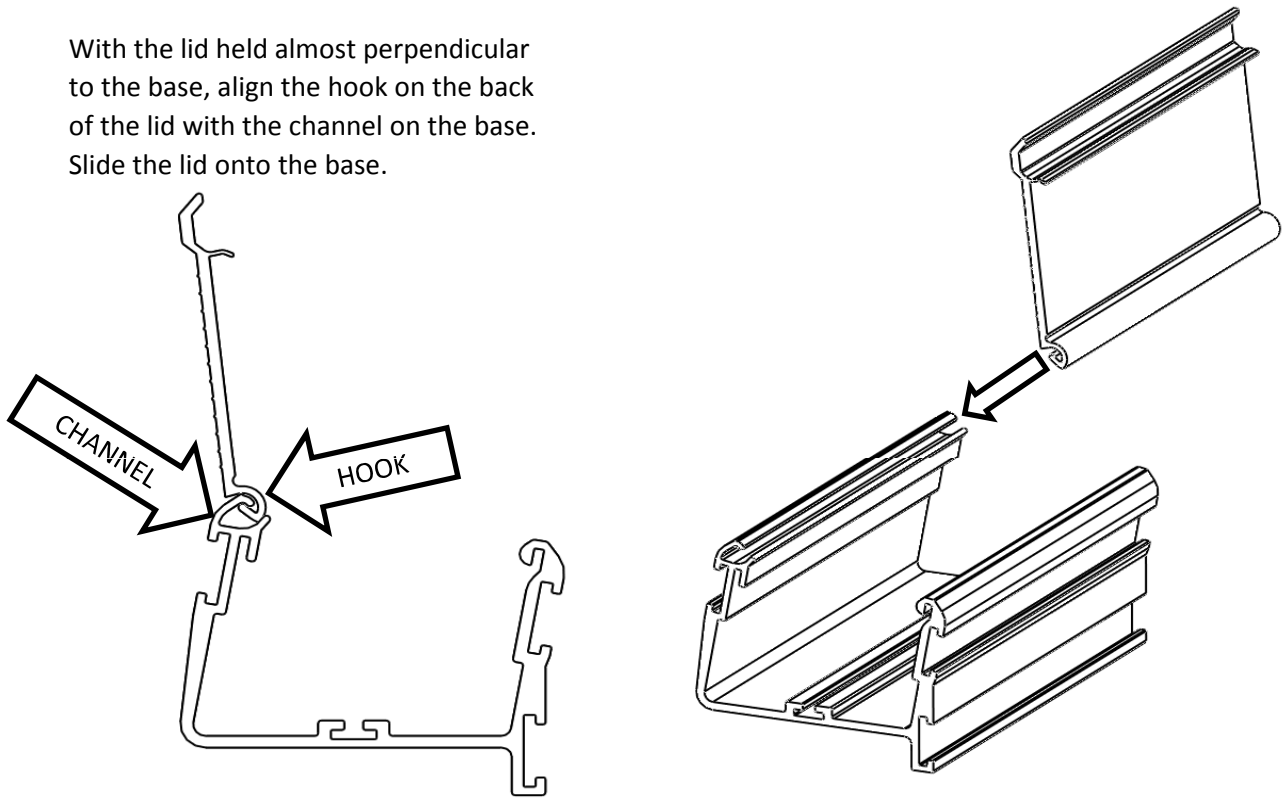

When the edges are flush, close the lid.

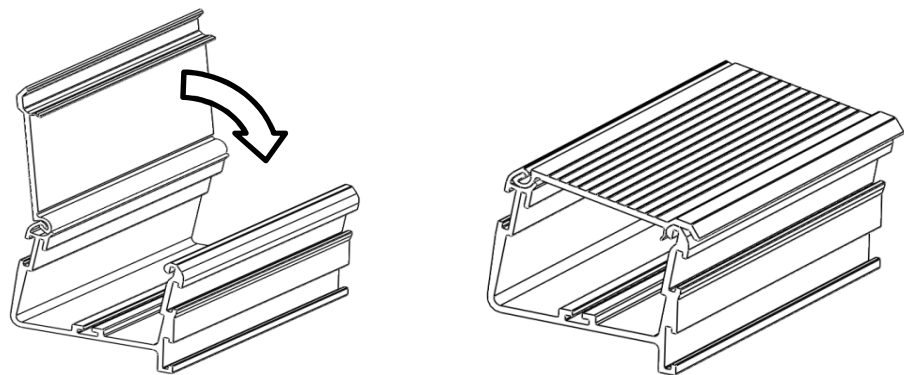

- 3** Set the first assembly [A] on the bed of the truck on the driver's side near the cab. This step is shown with the small bungee box for the 6' bed. If you are installing on a 5.5' bed, there will not be a bungee box, and you will only use one of the section cap [E] per side. If you are installing on an 8' bed, the bungee box will be longer than what is shown below, but will install in the same way. Assemble the sections as shown below.

The tabs in the section cap [E] fit into the extrusion as shown in this figure. When installed to outside profile of the section cap will match the extrusion profile.

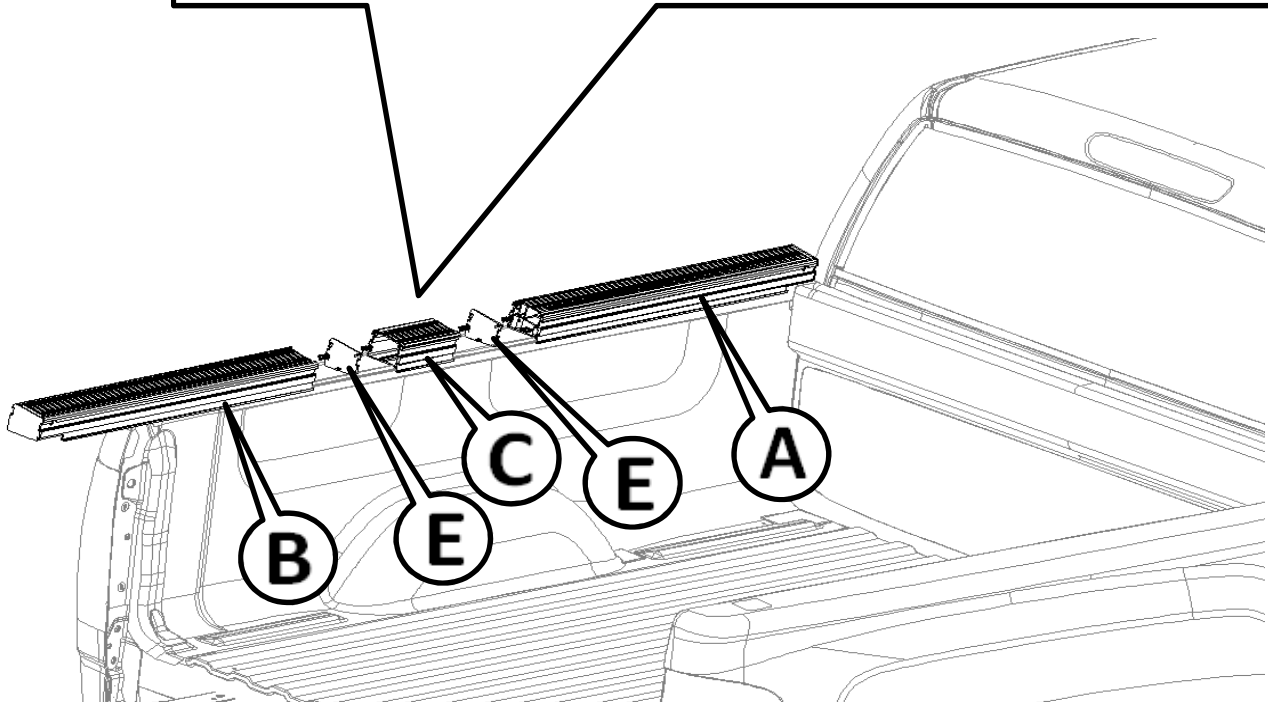
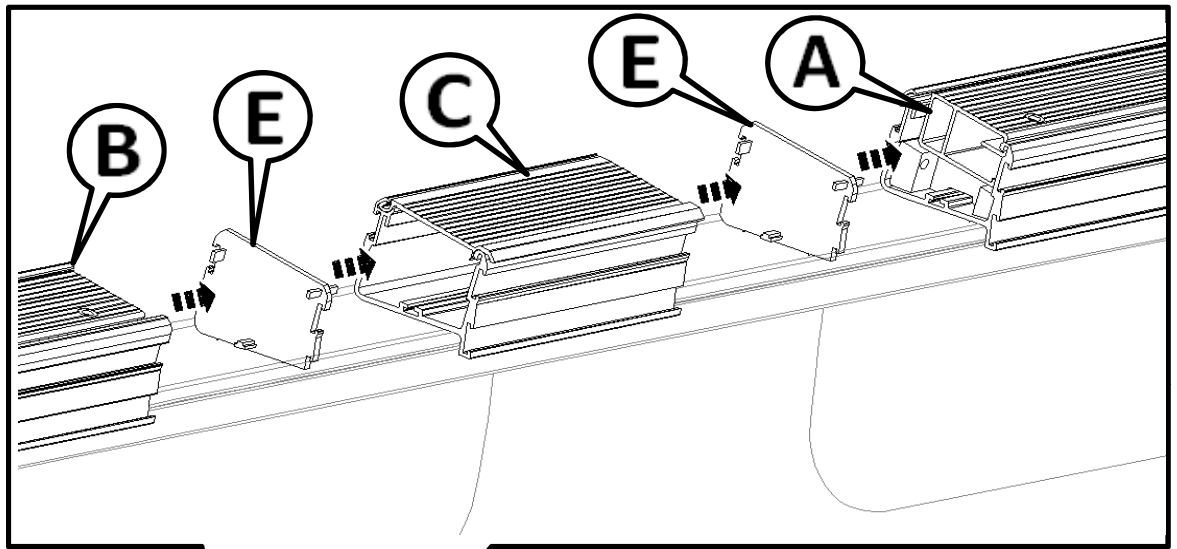
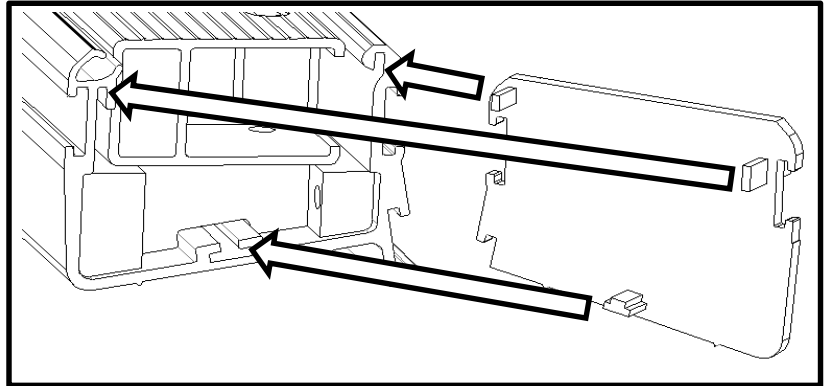

4

Thread one of the 3/8" nuts [H] onto the 3/8" bolt [G], then thread the bolt part way into the hole on the hold down clamp [D]. There will be 4 of these used per side.

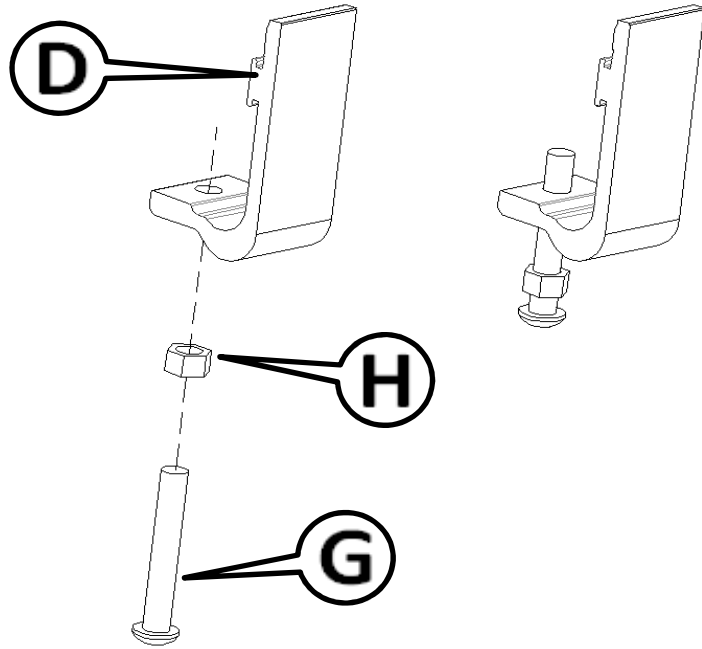

Slide the 4 hold down clamps into the bottom channel on the back side.

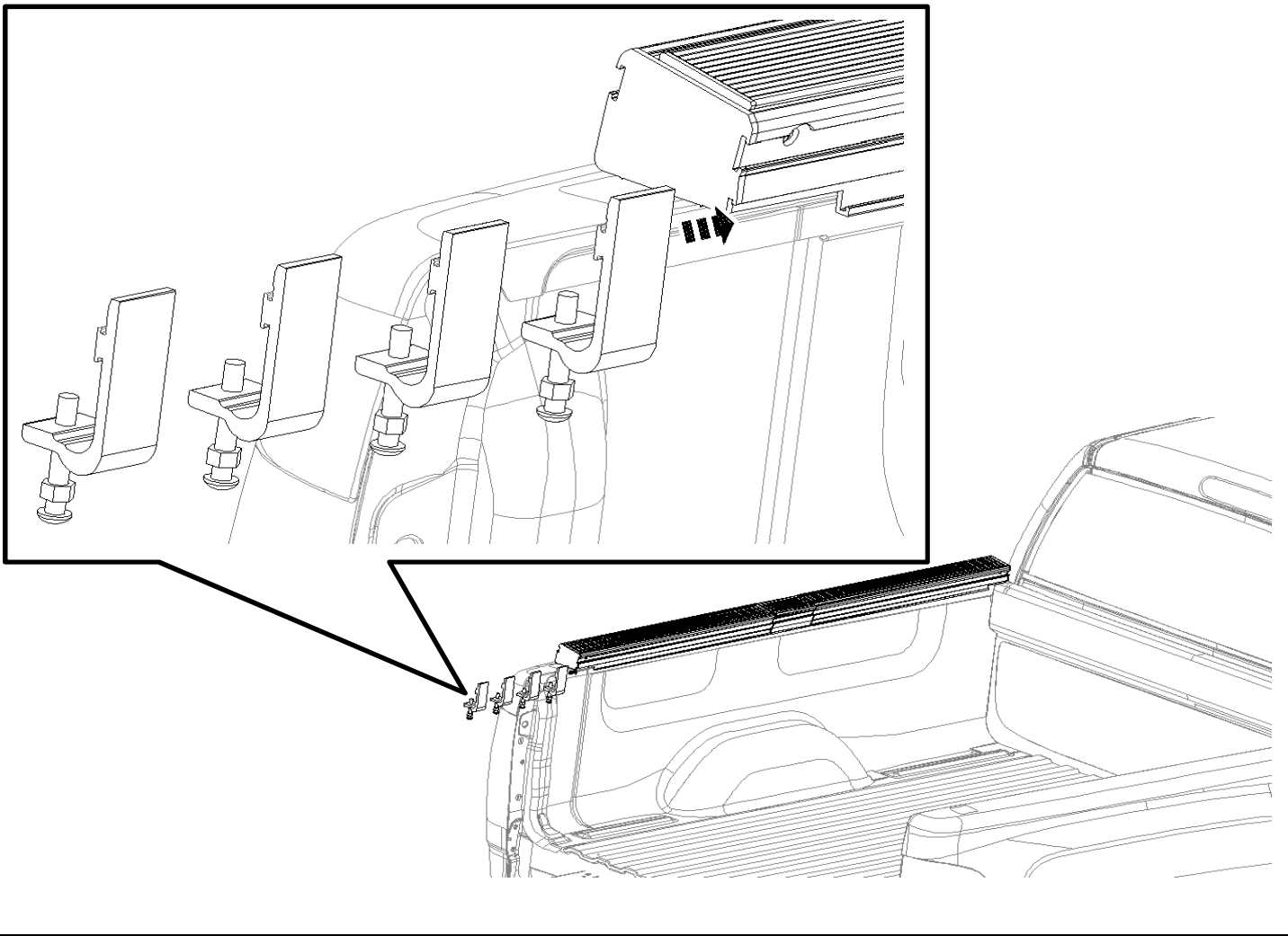

5

Use the images below to locate the hold down clamps for each truck bed length.

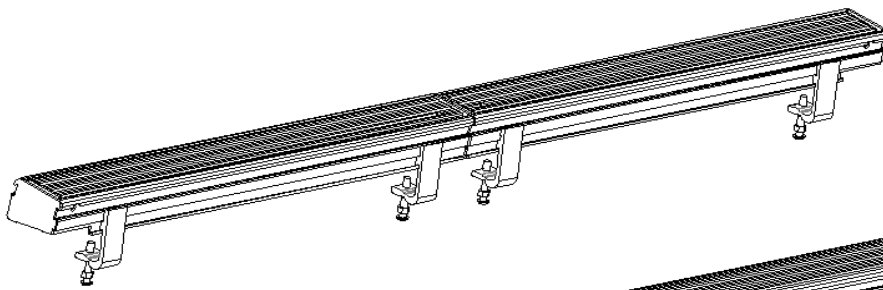

5.5' BED

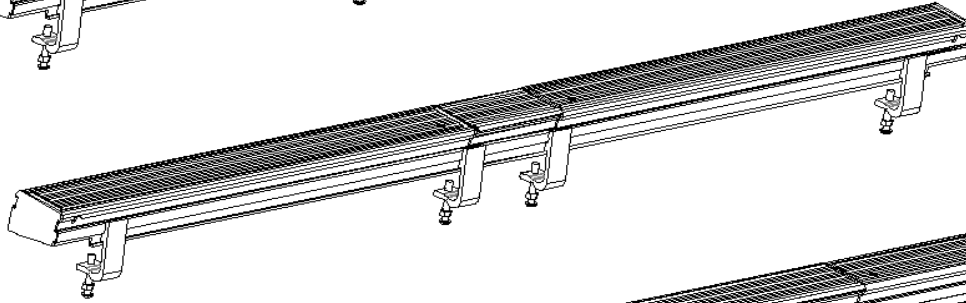

6' BED

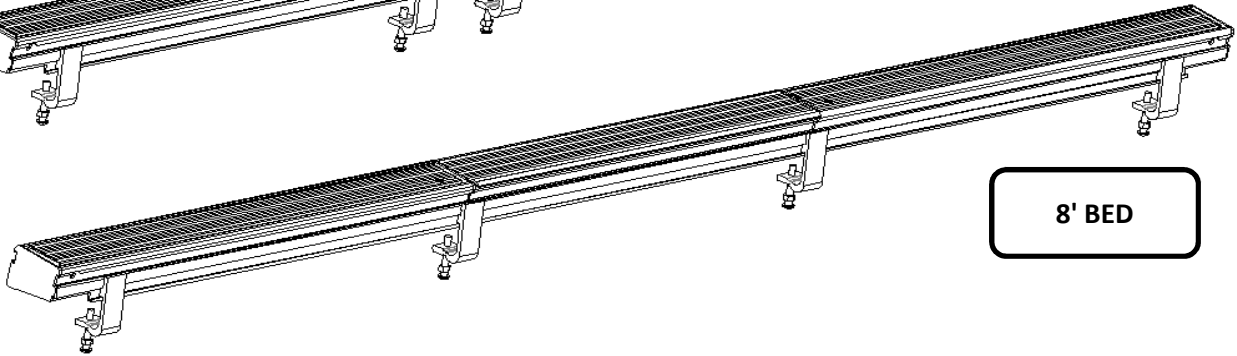

8' BED

The end hold down clamps should be as close to the end as the truck bed allows, but still completely in the channel of the extrusion.

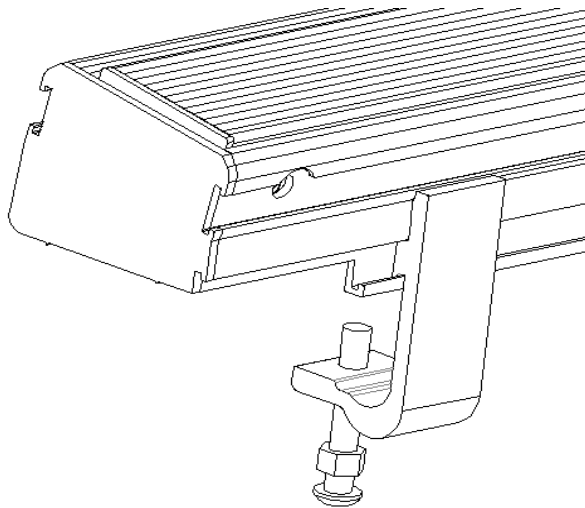

For applications with the bungee box, the hold down clamp needs to bridge the joint between the rack section and the bungee box equally.

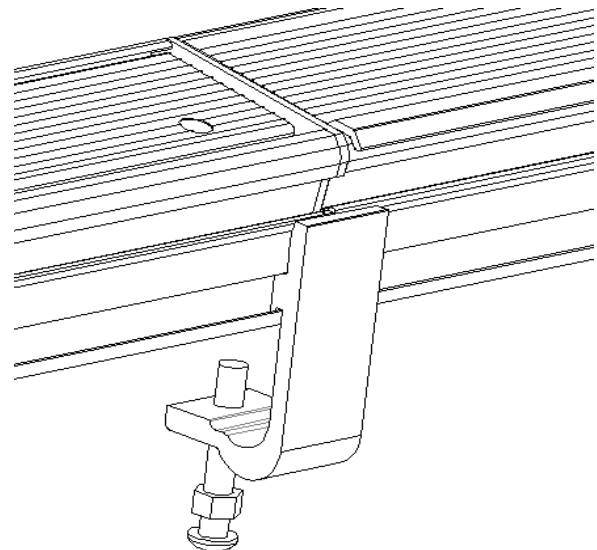

Note: Some trucks will have a center stake hole that will not allow the hold down clamp to bridge the joint of the main housing and bungee box. In this case, it is important to make sure that the two hold down clamps are installed on the front main housing and two hold down clamps are installed on the rear main housing (One as far forward as possible and one as far back as possible).

6 Tighten the bolts using a 7/32" allen wrench/socket. Start with the bolt closest to the cab and work your way to the bolt at other end of the bed. Repeat the process of tightening the bolts to insure that all are completely tighten.

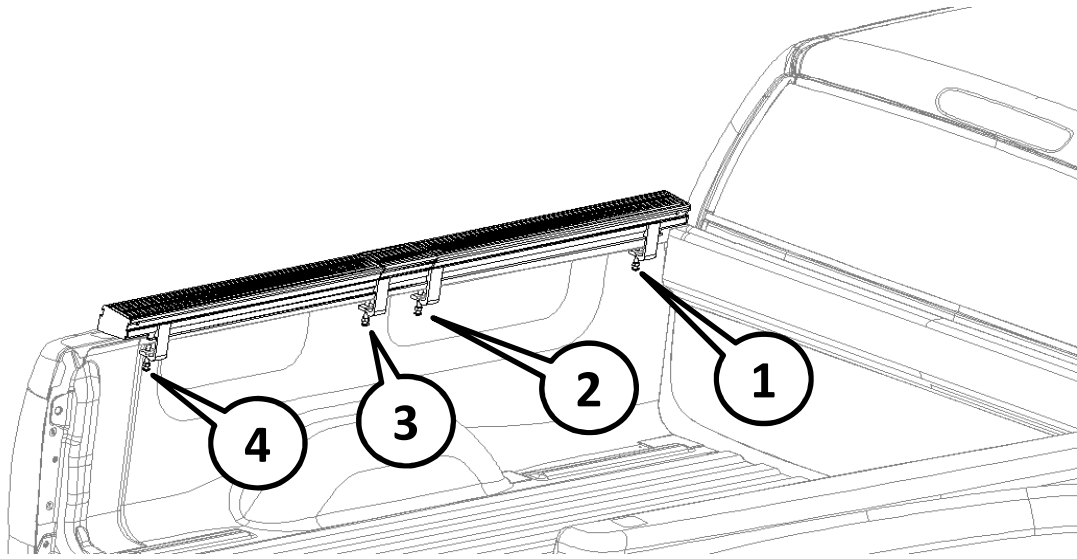

7 Once the 3/8" bolts have been tightened, using a 9/16" open end wrench, tighten the nut against the bottom of the hold down clamp.

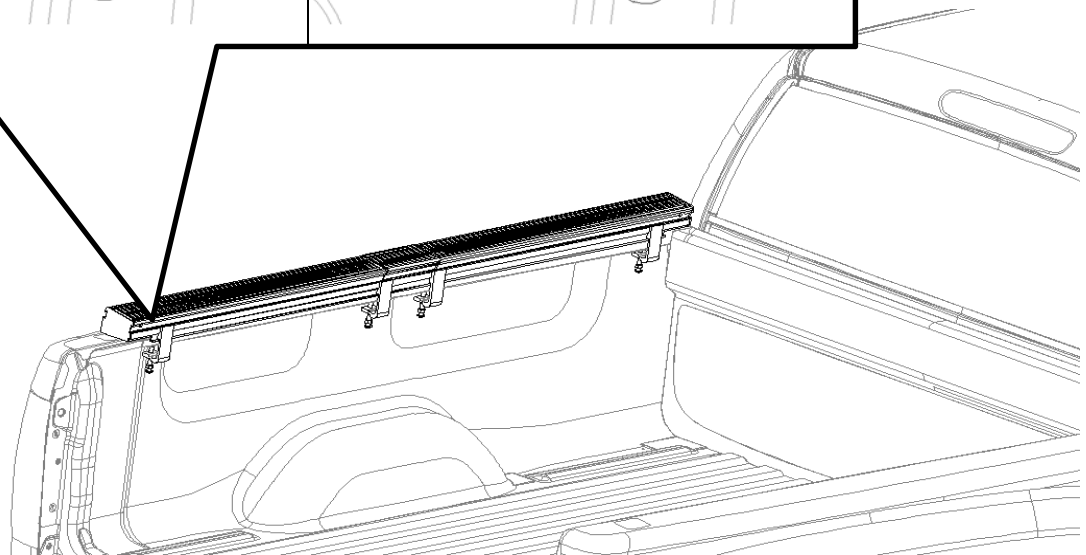
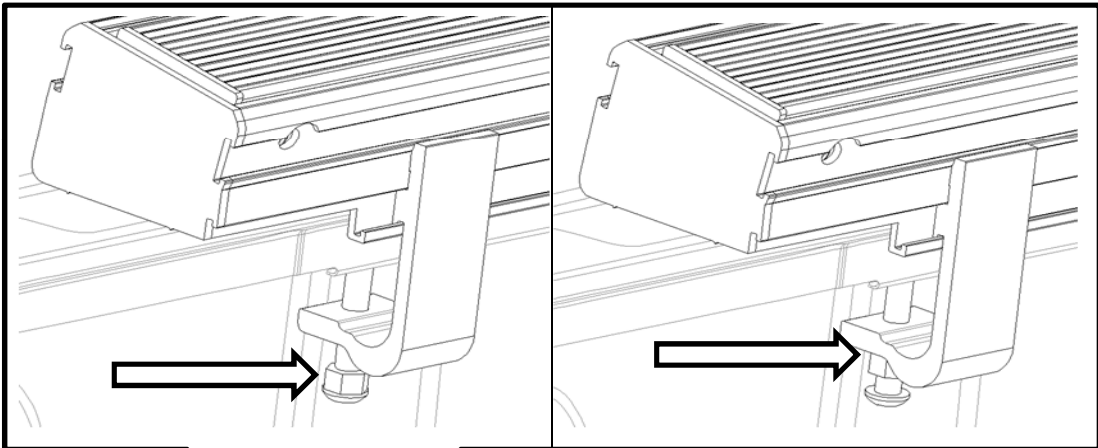

8

Repeat these installation steps for the other side of the bed.

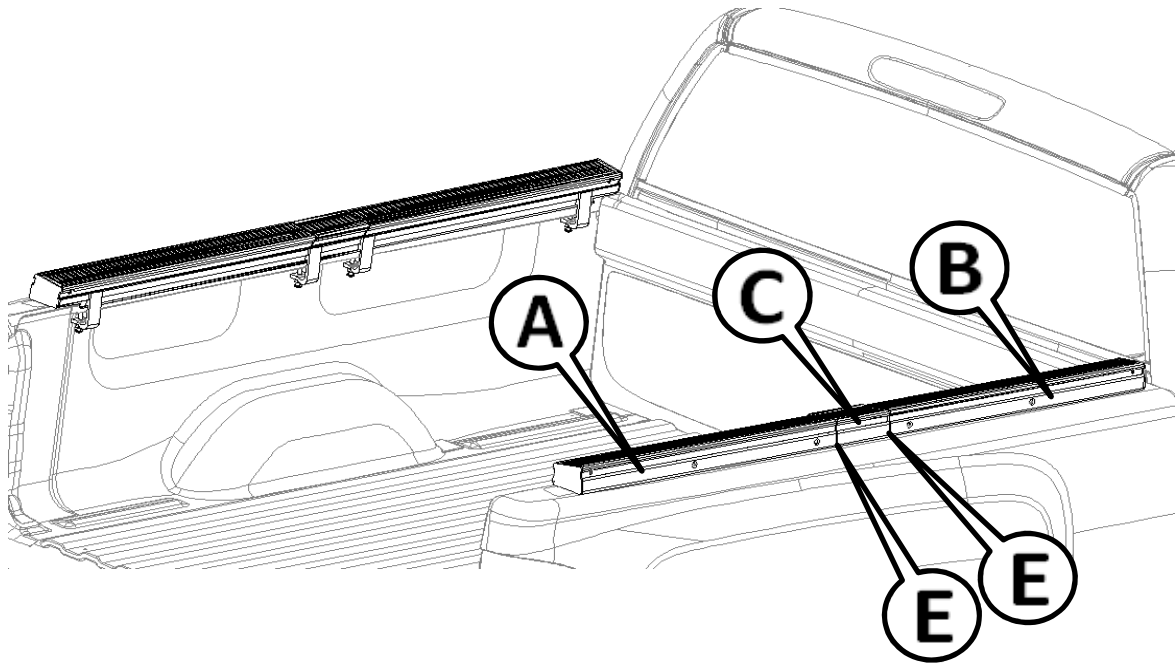

9

To use the Invis-a-rack, pull up on the top section using the cut out provided.

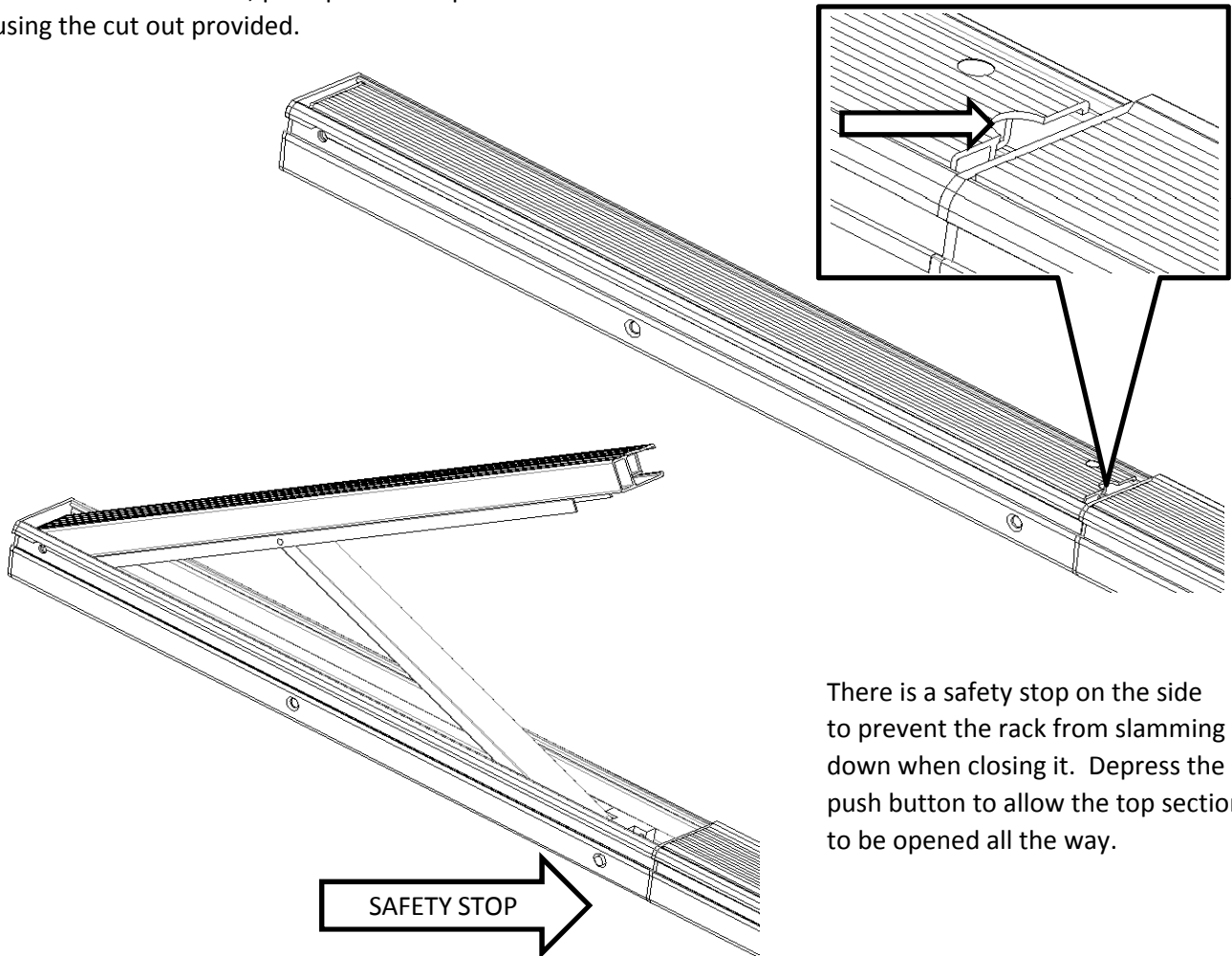

There is a safety stop on the side to prevent the rack from slamming down when closing it. Depress the push button to allow the top section to be opened all the way.

10

Extend the top section until the spring button engages the second hole on the side.

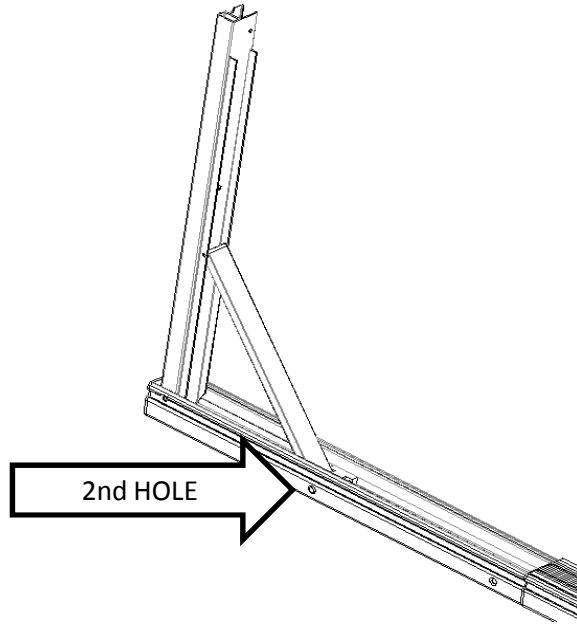

11

On the inside of the top section, pull up on the material arm. Extend the material arm until the push button engages the push button hole.

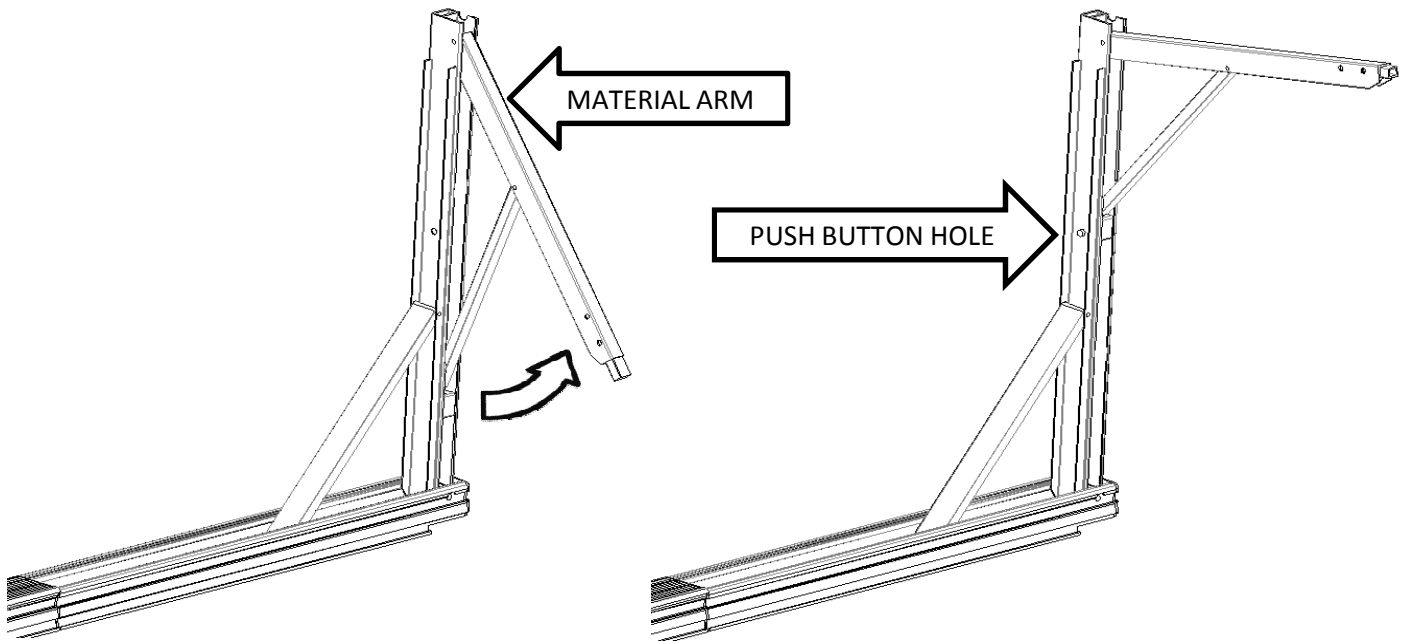

Repeat these steps for the other side.

12

Once both sides have been extended, press the push button in the cross bar and pull it out.

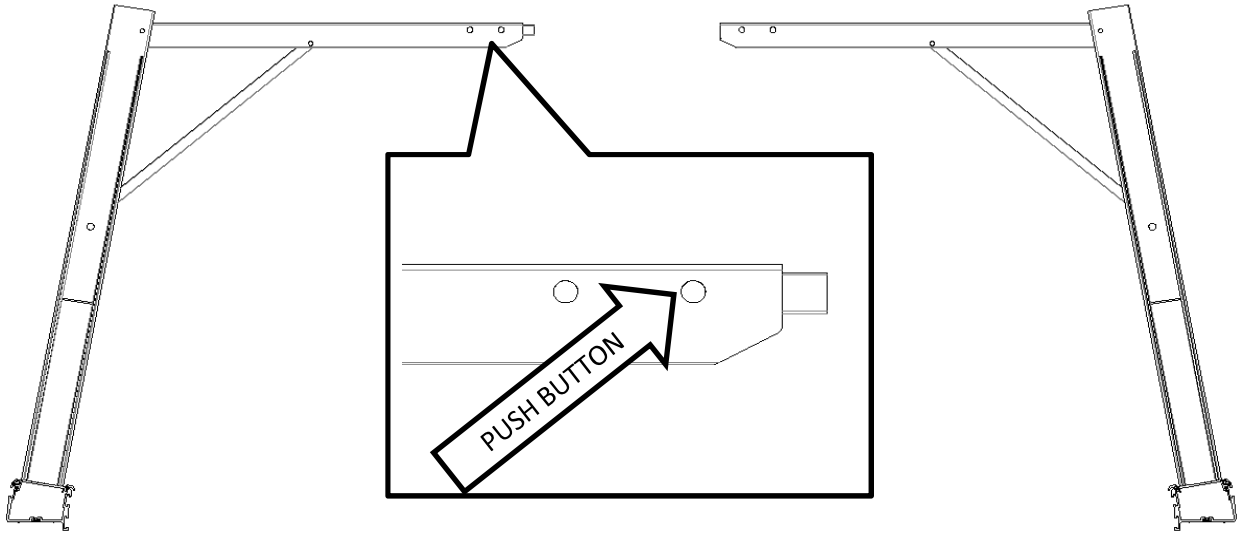

Insert the cross bar into the other side of the rack and engage the push button in the first hole.

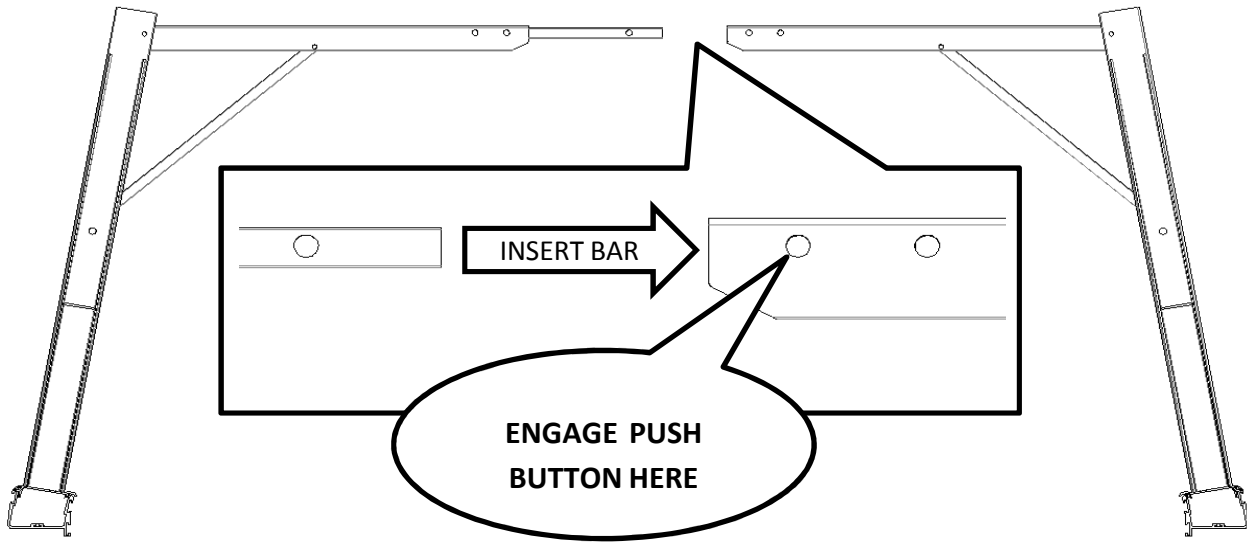

13

After engaging the push button, push the two halves of the rack apart, until the other push button engages. Do NOT use the rack with out both push buttons engaged.

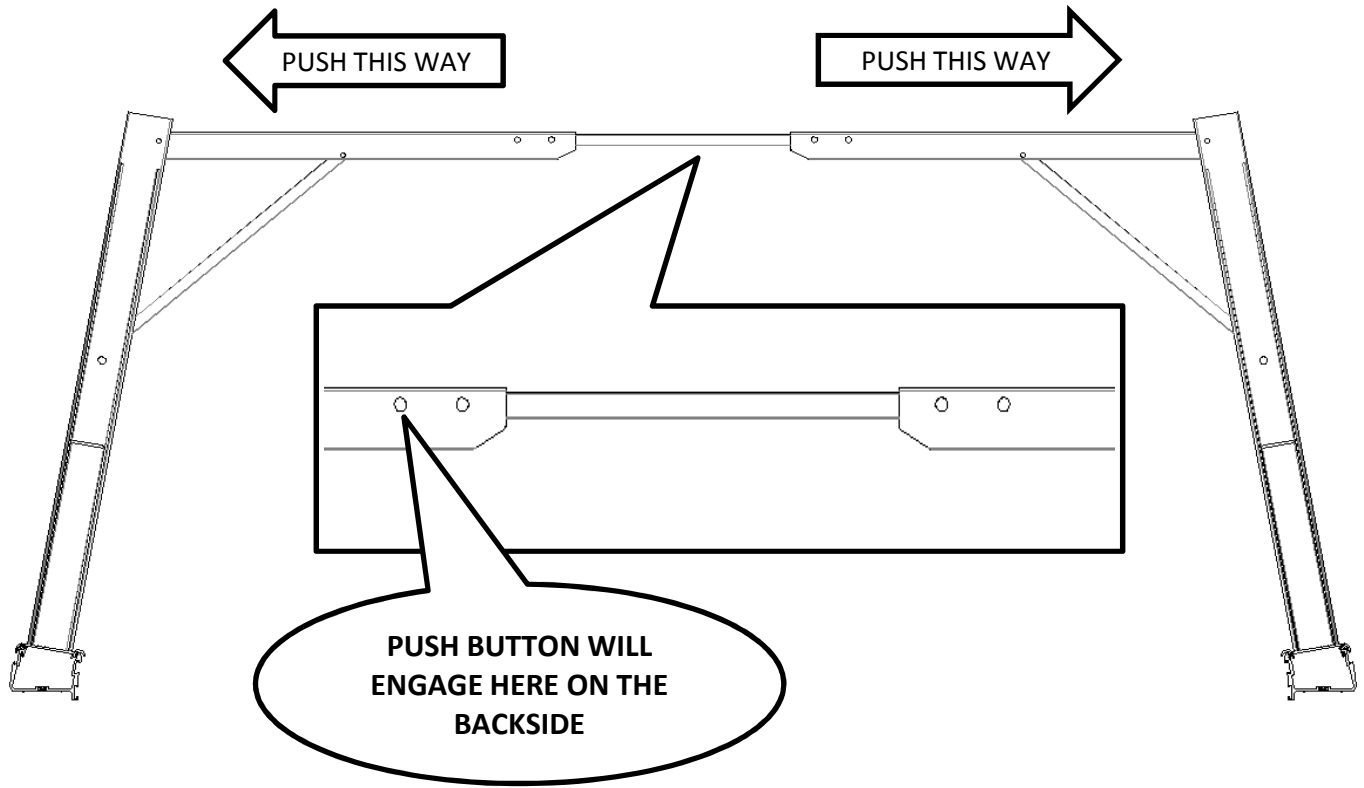

When installed on the Ford superduty, the second push button will engage the 2nd hole.

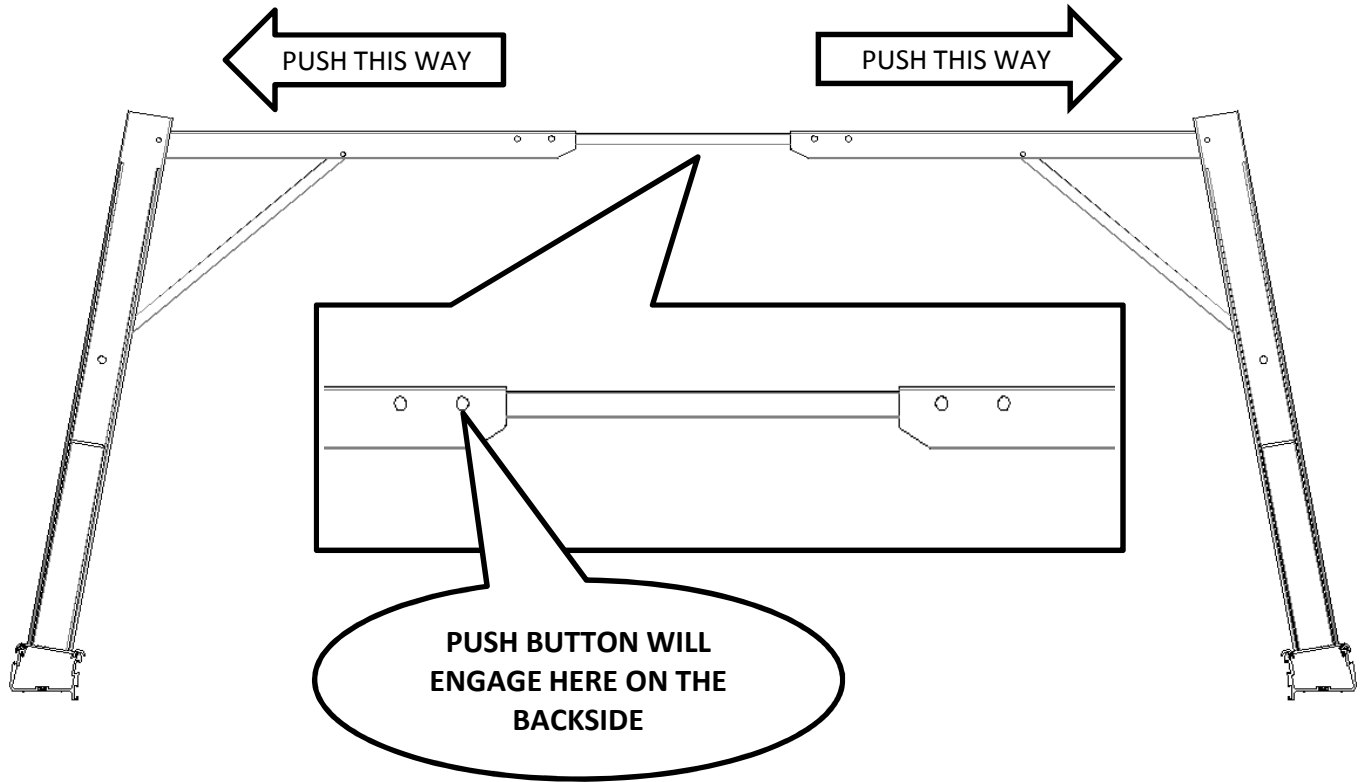

14

To stow the Invis-a-rack, depress the push button that was engaged in the previous step and pull the two halves of the rack towards each other.

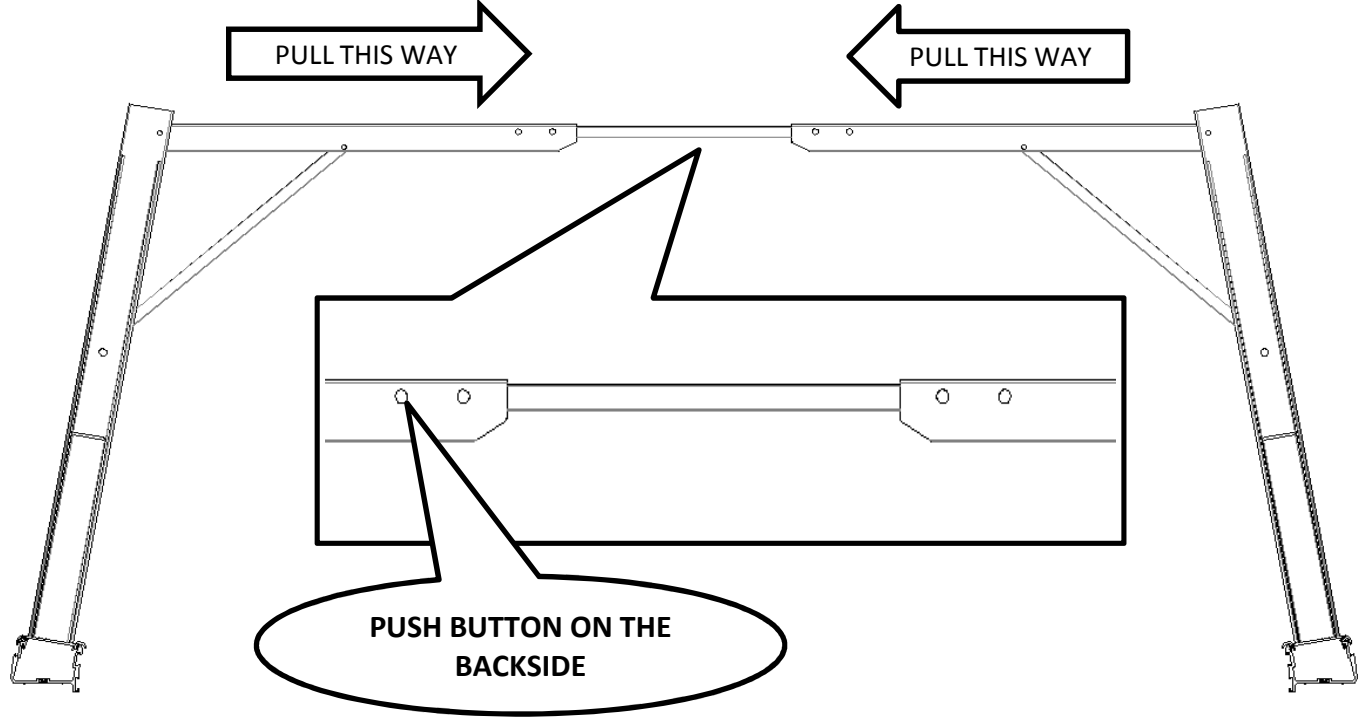

Disengage the other push button on the cross bar and slide it out.

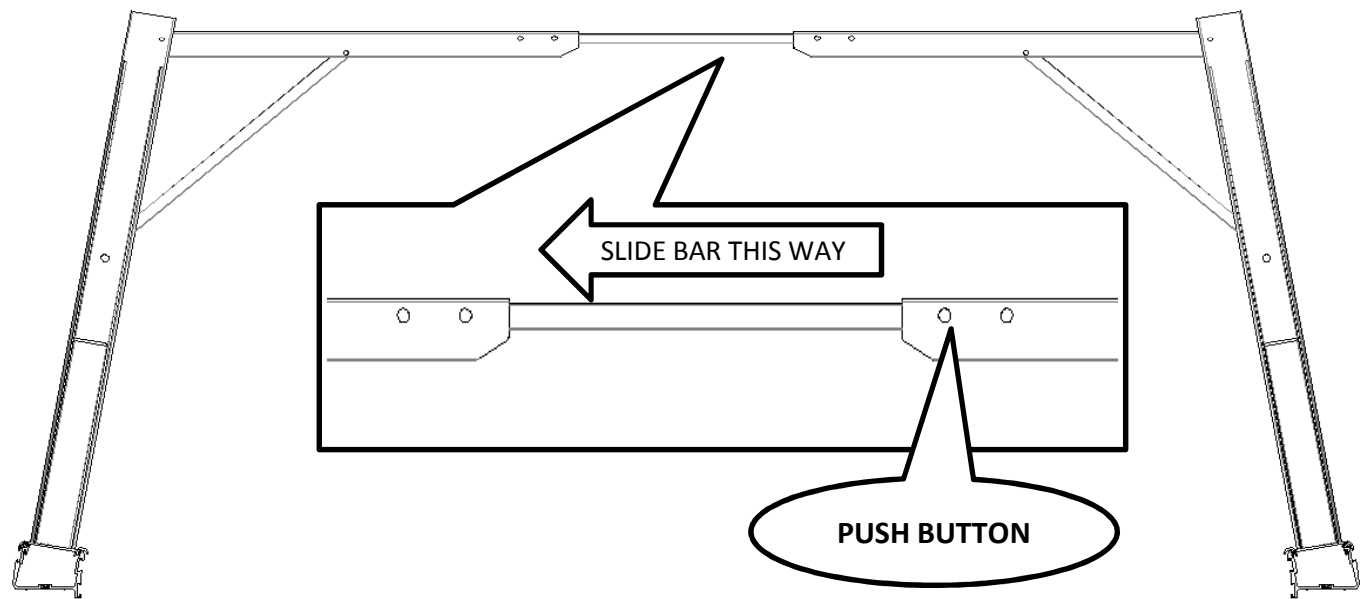

Slide the cross bar back until the push button engages in the first hole.

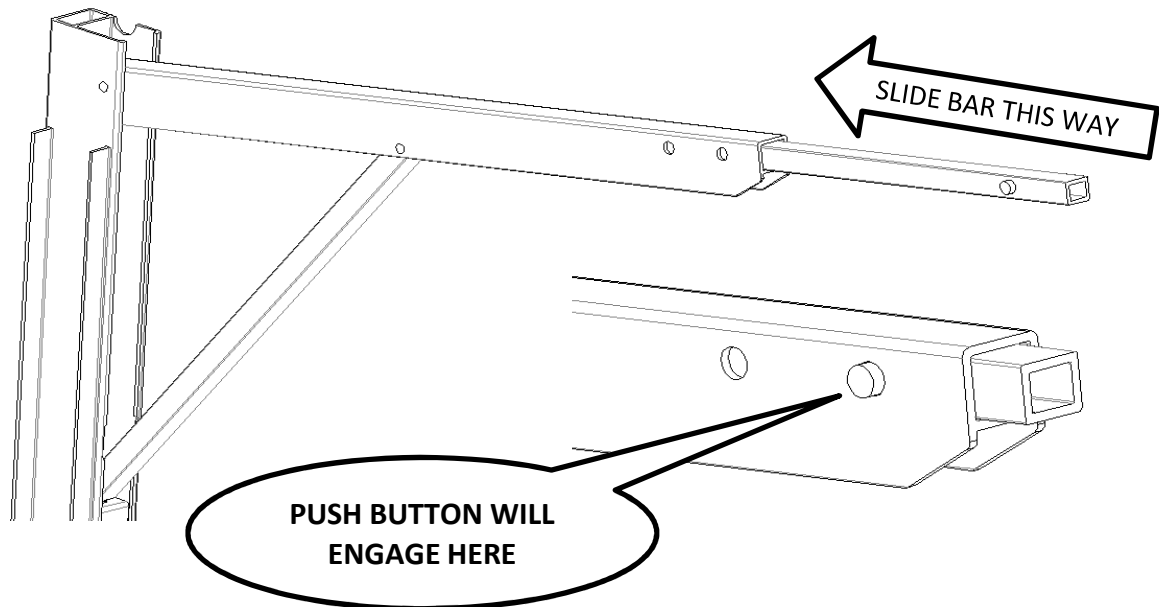

Depress the push button and bring the material arm down.

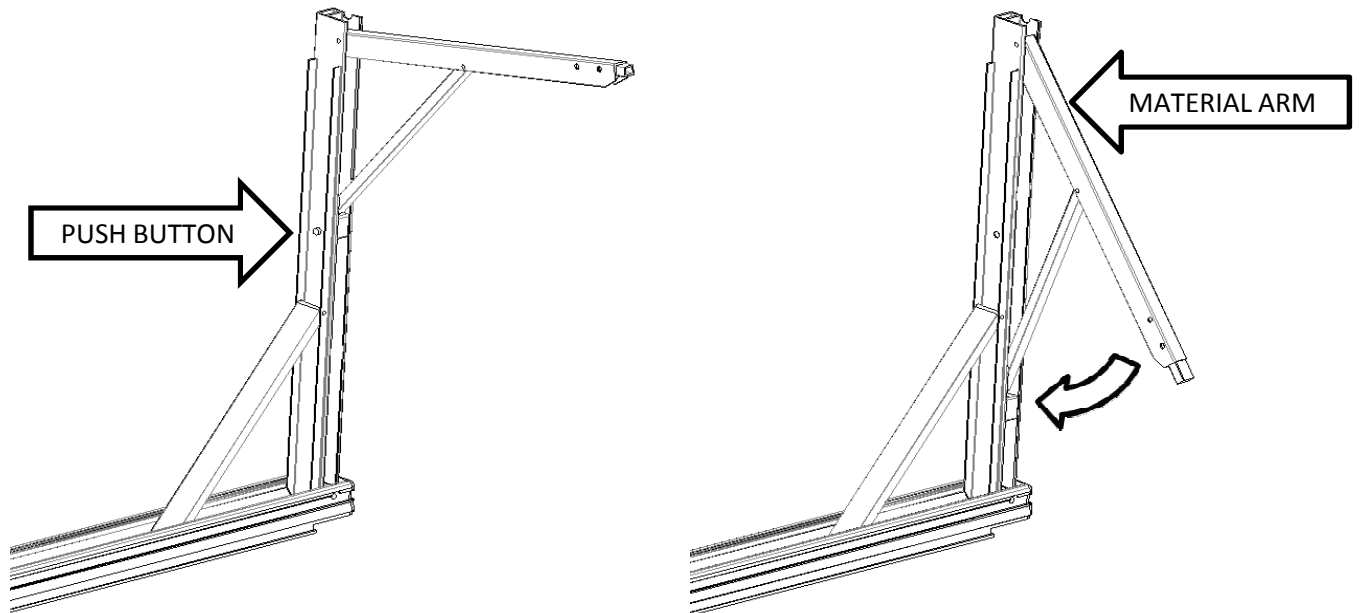

Depress the push button to lower the remaining part of the rack.
Then depress the push button in safety stop to complete the stowing of the rack.

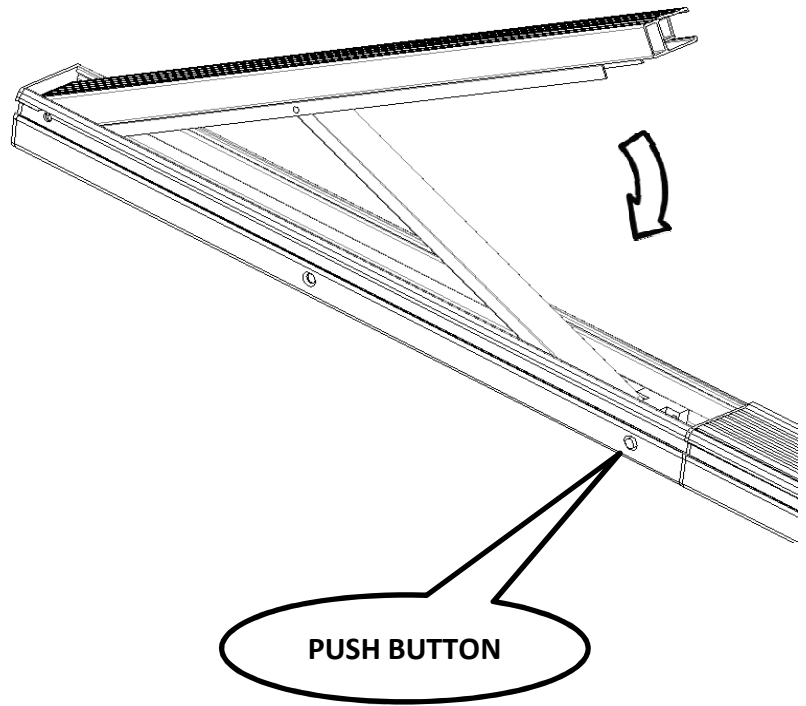
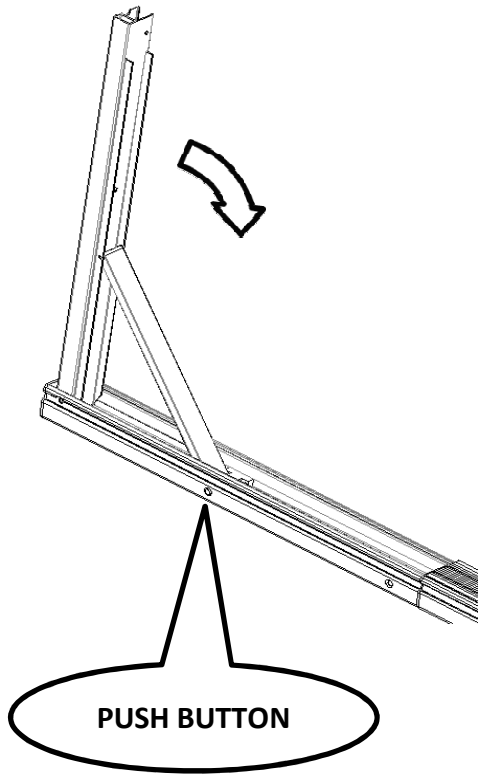

Repeat these step for the remaining portions of the rack.