



## Dee Zee Toolbox Installation Instructions

***Congratulations on your purchase of a quality Dee Zee product. Dee Zee is recognized as having the highest quality running boards and accessories on the market today. We have earned this reputation by offering our customers a product they can be proud to place on their vehicles. Dee Zee meets all the criteria of manufacturing a custom-fit product which guarantees it to be the easiest product to install.***

**Note: Please take time to read all of the instructions before beginning this installation.**

**Note: Use J-Bolt provided or WARRANTY IS VOID...DO NOT USE self tapping screws to mount.**

**Warning! If it is necessary to drill any holes into the vehicle, Dee Zee recommends putting a sealant or rust inhibitor around all holes drilled into the body of the vehicle.**

**Cleaning Instructions: To maintain the bright finish of your Dee Zee Stainless Steel Toolbox, clean with a mild detergent and then apply a high grade automotive type wax.**

# Fifth Wheel Tool Box Installation Instructions

## Fifth Wheel Toolbox:

Toolbox lid design may vary from picture with different toolbox models.

Cinquième

**Fifth Wheel  
Toolbox-Front**

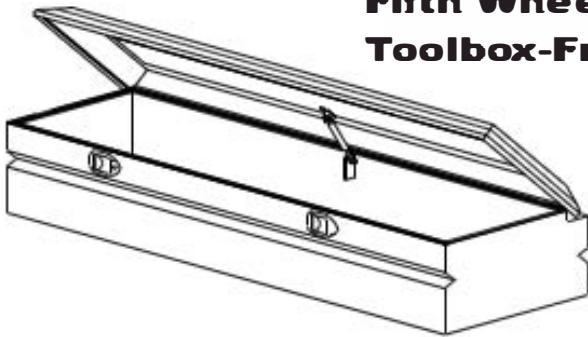

**A**

**Fifth Wheel  
Toolbox-Rear**



**X1**

**B**

1/4 x 1" Sheet  
Metal Screw



**X4**

**C**

Foam Tape



**X2**

**Tools Required:  
Outils Nécessaires:**

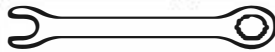

**3/8"**



**3/16"**



**1** Peel backing off of foam tape (C).

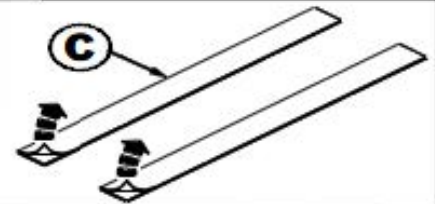

**2** Place foam gasket ( ) onto the bottom of Fifth wheel toolbox (A). Turn foam gasket ( ) so that it is flush with the ends of fifth wheel toolbox (A).

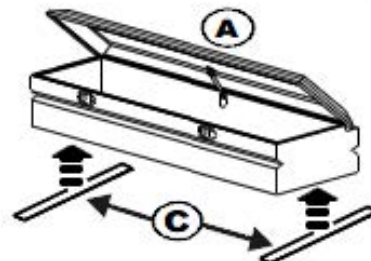
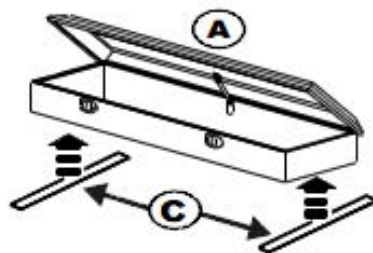
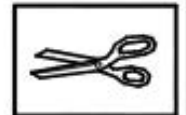

**3**

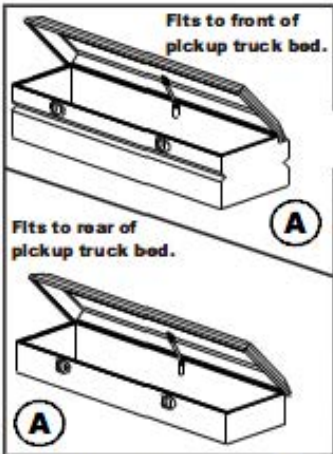

Place fifth wheel toolbox (A) into the back of your pickup truck bed.

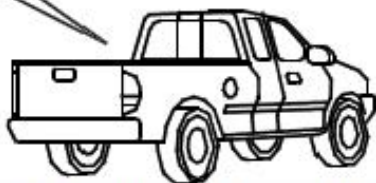

**4**

Locate the fifth wheel toolbox (A) in the pickup truck bed and then mark four hole locations in the bottom of fifth wheel toolbox (A). Drill a 3/16" hole at each marked hole location.

cinquième

cinquième

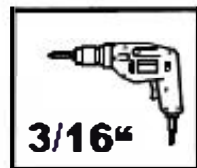
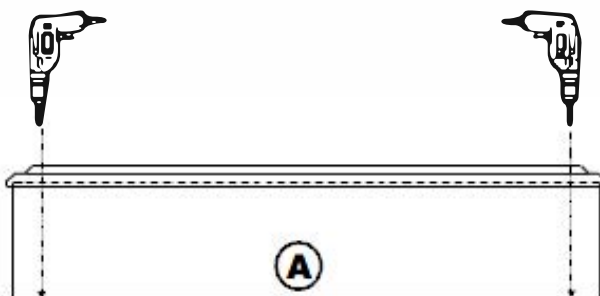

**5**

Attach fifth wheel toolbox (A) to the pickup truck bed using 1/4 x 1" sheet metal screws (B). Tighten them into place using a 3/8" wrench / or socket.

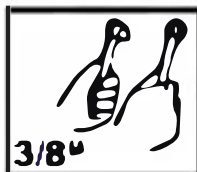
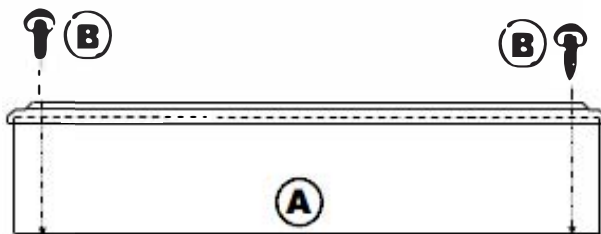

**MAINTENANCE INSTRUCTIONS:** All locks, latches, latching rods, and hinges should be lubricated regularly to assure smooth and proper operation for the life of the toolbox.

**Toolbox Paddle Latch Assembly**

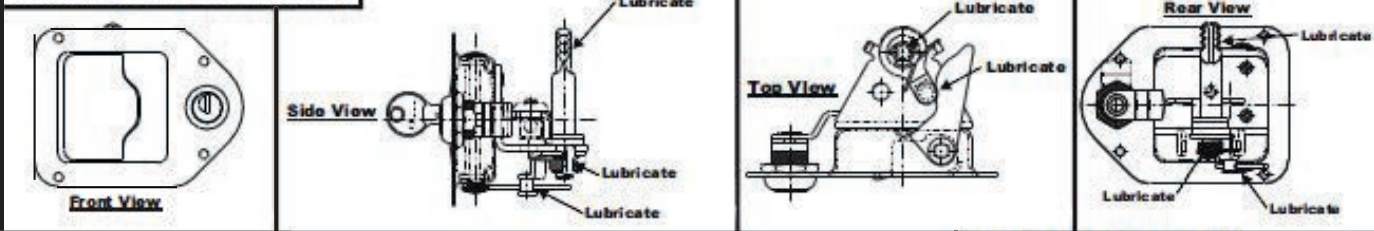

**Toolbox Catch Assembly**

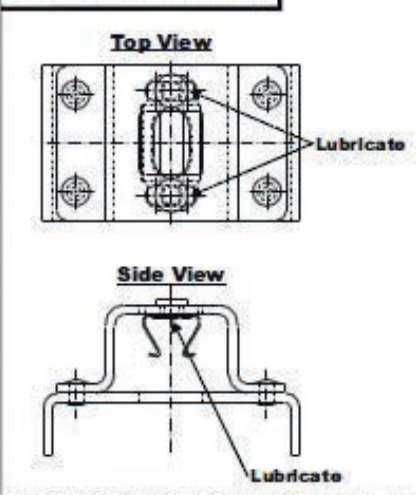

# Replacement Parts for 5th Wheel Toolbox

## Toolbox Hook-Paddle Latch Assembly

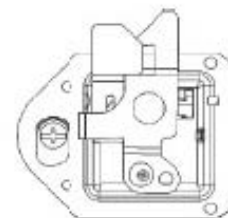
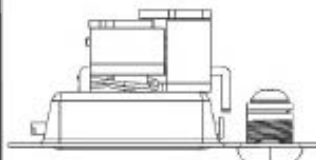
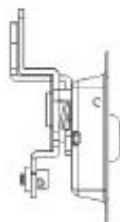
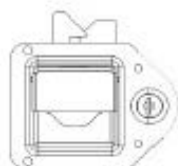

## Toolbox Hook-Catch Assembly

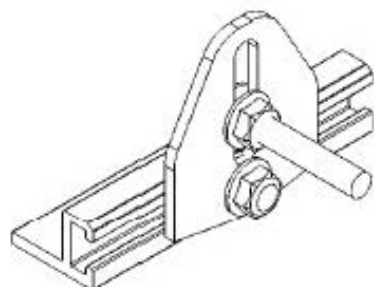

**C-Channel Extrusion**  
Part Number: B 1602



**Rotary Plate - Adjustable Latch**  
Part Number: B 1601



**1/4-20 Hex Head Cap Screw**  
Part Number: PN 708



**1/4-20 Threaded Stud**  
Part Number: PN 810



**1/4-20 Flange Locknut Zinc**  
Part Number: PN 178



**1/4-20 Nylon Locknut Ultra**  
Part Number: PN 341B



**Nylon Standoff**  
Part Number: PN 860



## Pushbutton - Blue Series

**Spacer Brace for Push Button**  
Part Number: B 1623



**Adjustable Latch**  
Part Number: B 1610



**Carburetor Clip 7R**  
Part Number: LCC-2



**Mounting Bracket**  
Part Number: B 1625



**Shock Mount**  
Part Number: 3L-09



**Nylon Bushing**  
Part Number: PN 118



**5/16-18 Nyl Insert Locknut**  
Part Number: PN 510



**10 x 1/8 Square Pan Self Drill**  
Part Number: PN 872



**Push Latch**  
Part Number: TB 85623



**Rotary Latch**  
Part Number: TB 85624



**Rod End Adaptor**  
Part Number: TB 85626



# Replacement Parts for 5th Wheel Toolbox Cont.

## Shocks

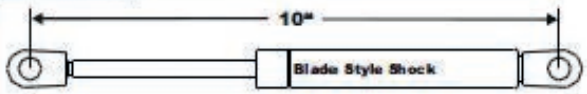

Blade Style Shock			
Shock #	20#	40#	70#
Part Number	SL1-20	SL1-40	SL1-70

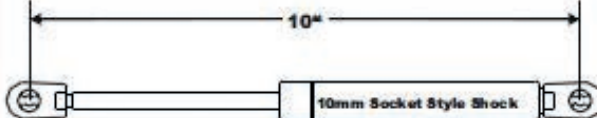

10mm Socket Style Shock			
Shock #	20#	40#	70#
Part Number	SL-3020	SL-3040	SL-3070

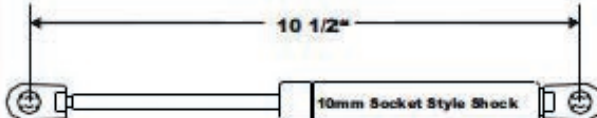

10mm Socket Style Shock					
Shock #	20#	40#	60#	80#	100#
Part Number	SL-3220	SL-3240	SL-3260	SL-3280	SL-321000

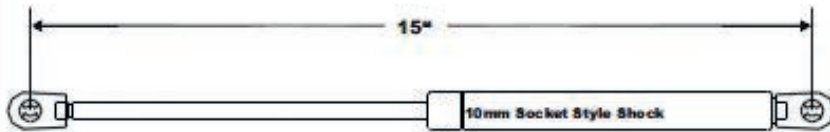

10MM Socket Style "Long" Style Shock		
Shock #	90#	40#
Part Number	SL-3390	SL-3340

## Miscellaneous Parts

Foam Latch Gasket  
Part Number: T88540B

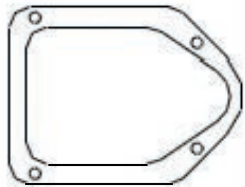

Shock Clip  
Part Number: SL-81



Striker Assembly  
Part Number: T885616



Shock Mount Nut  
Part Number: PN 301



Latch Cover Rivet  
Part Number: PN 285

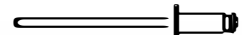

Latch Rivet  
Part Number: PN 157

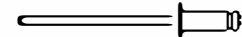

Hinge Rivet  
Part Number: PN 762

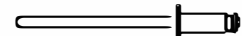

Shock Mount  
Part Number: SL-69

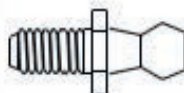

Rod Clip  
Part Number: L0C-1

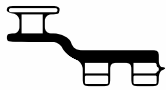

Rod Guide  
Part Number: T886616



1/4" Flat Washer  
Part Number: PN 72B



1/4 x 1" Sheet Metal Screw  
Part Number: PN 67B



1/4 x 1" Sheet Metal Screw  
Part Number: PN 67



1/4 x 1" Button Head Screw  
Part Number: PN 96B



1/4" Locknut  
Part Number: PN 341B



Mounting Bracket  
Part Number: T8BRACE1



Divider Mounting Channel  
Part Number: TB Channel



Toolbox Divider  
Part Number: TB Divider



Toolbox Divider Tape  
Part Number: CO-Tape



Rear View: Locking Latch  
Part Number: T885613

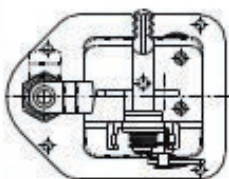

Rear View: Non-Locking Latch  
Part Number: T885614

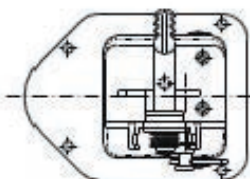

Rear View: Locking Hook  
Part Number: T885608

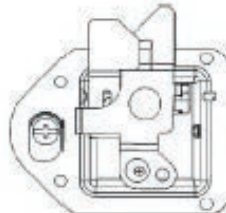

Rear View: Non-Locking Hook  
Part Number: T885608

