



**Before returning this product  
to the store of purchase**

Contact manufacturer if you experience the following problems:

- Missing Parts
- Installation Problems / Questions
- Warranty Questions



## Dee Zee Toolbox Installation Instructions

*Congratulations on your purchase of a quality Dee Zee product. Dee Zee is recognized as having the highest quality running boards and accessories on the market today. We have earned this reputation by offering our customers a product they can be proud to place on their vehicles. Dee Zee meets all the criteria of manufacturing a custom-fit product which guarantees it to be the easiest product to install.*

**Note:** Please take time to read all of the instructions before beginning this installation.

**Warning!** If it is necessary to drill any holes into the vehicle, Dee Zee recommends putting a sealant or rust inhibitor around all holes drilled into the body of the vehicle.

**Cleaning Instructions:** To maintain the bright finish of your Dee Zee Stainless Steel Toolbox, clean with a mild detergent and then apply a high grade automotive type wax.

# Side Mount / Topsider Toolbox Installation Instructions

This toolbox installation instruction is for both Single-Lid Toolboxes and Double-Lid Toolboxes.

Cette instruction d'installation de boîte à outils est pour des boîtes à outils de Single-Lid et des boîtes à outils de Double-Lid.

**A**

**Britetread Side Mount Toolbox:**





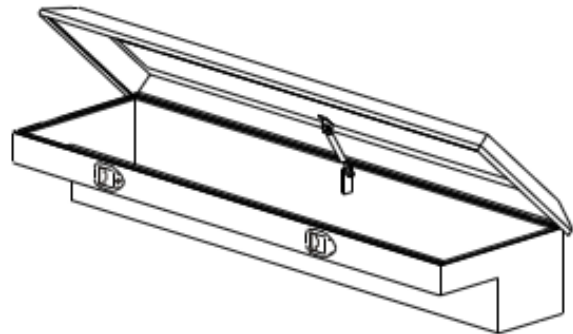

Toolbox lid design may vary from picture with different toolbox models.

**Boîte à outils De Support De Côté De Britetread:**

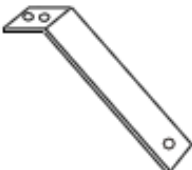
La conception de couvercle de boîte à outils peut changer de l'image avec différents modèles de boîte à outils.



**X1**

<p><b>B</b></p> <p>Mounting Bracket</p>  <p><b>X4</b></p>	<p><b>C</b></p> <p>Foam Tape</p>  <p><b>X2</b></p>	<p><b>D</b></p> <p>1/4" Flat Washer</p>  <p>Black</p> <p><b>X12</b></p>	<p><b>E</b></p> <p>1/4 x 1" Sheet Metal Screw</p>  <p>Black</p> <p><b>X4</b></p>	<p><b>F</b></p> <p>1/4 x 1" Sheet Metal Screw</p>  <p><b>X8</b></p>
<p><b>G</b></p> <p>1/4 x 1" hex cap screw</p>  <p><b>X8</b></p>	<p><b>H</b></p> <p>1/4" Nylon insert lock nut</p>  <p><b>X8</b></p>			

**Tools Required:  
Outils Nécessaires:**

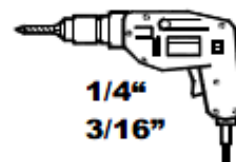
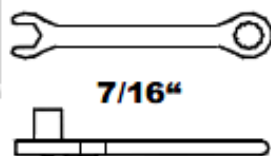

**1**

Use the pictures to the right as a guide in locating the side mount / tepsider toolbox (A). Note: If the side mount / tepsider toolbox (A) is to be installed with a front mount toolbox (As shown in Drawings B and C), be sure to leave enough space between the toolboxes to allow clearance to open both toolbox lids.

Utilisez les images vers la droite comme guide en localisant la boîte à outils de support de côté de britetread (a). Note: Si la boîte à outils de support de côté de britetread (a) est d'être installée avec une boîte à outils avant de support (comme montré dans les schémas B et C), soit sûr de laisser assez d'espace entre les boîtes à outils pour permettre au dégagement d'ouvrir les deux couvercles de boîte à outils.

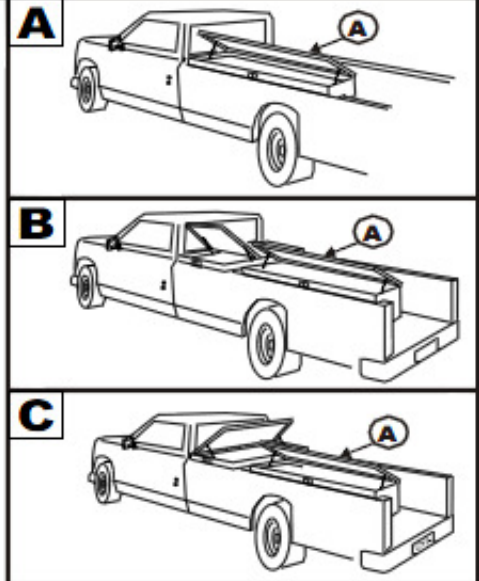
**2**

Pool backing off of foam tape (L).

Dégagement de peau de la bande de mousse (L).

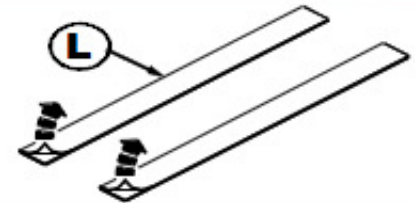
**3**

Place foam tape (L) onto the bottom of side mount / tepsider toolbox (A) to protect the bed rail of the vehicle.

Placez la bande de mousse (L) sur le bas de la boîte à outils de support de côté de britetread (a) pour protéger le rail de lit du véhicule.

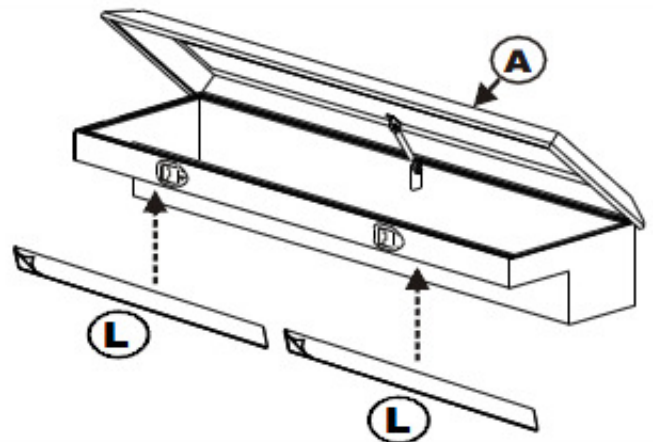
**4**

Drill 3/16" holes through the inside side mount / tepsider toolbox (A) and the pickup truck bed rail according to the part number listed below:

- 1) 48 / tepsider - Drill four holes through the bed rail.
- 2) 60, 68 - Drill six holes through the bed rail.
- 3) 87 - Drill eight holes through the bed rail.

Secure into position using 1/4 x 1" sheet metal screws (F). Tighten into place using a 7/16" wrench / or socket. Note: Do not overtighten the sheet metal screws. Make sure that if your vehicle already has a crossover toolbox installed, that you position your side mount toolbox so that it is aligned with the crossover toolbox.

Forez 3/16" des trous par la boîte à outils intérieure de support de côté de britetread (a) et le rail de lit de petit camion selon le numéro de la pièce énuméré ci-dessous:

- 1) 48 - Exercices quatre trous par le rail de lit.
- 2) 60, 68 - Exercices six trous par le rail de lit.
- 3) 87 - Exercices huit trous par le rail de lit.

Fixez en l'place en utilisant 1/4 x 1" les vis en métal de feuille (F). Serrez dans l'endroit en utilisant un 7/16" clé / ou plot. Note: Ne trop serrez pas les vis en métal de feuille. Assurez-vous que si votre véhicule a déjà une boîte à outils de pont installée, cela vous placent votre boîte à outils latérale de support de sorte qu'il soit aligné avec la boîte à outils de croisement.

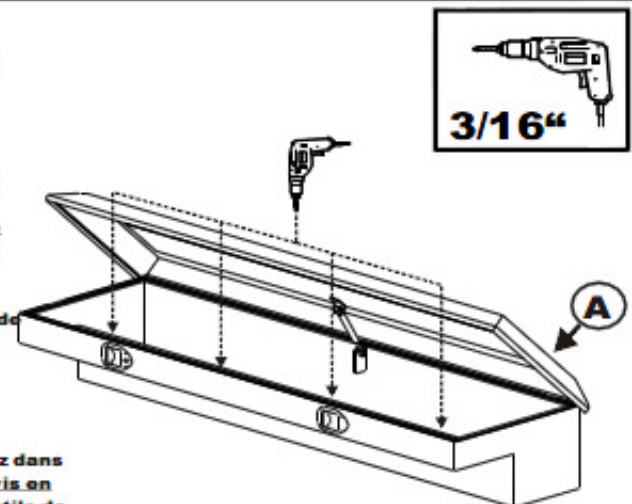



**5**

Hold the side mount / topsider toolbox (A) level while positioning mounting bracket (B) as shown below. Once the toolbox (A) is level and the mounting brackets (B/B) are in the desired position, use a pair of vise-grips to hold them together. Now use the existing holes in mounting bracket (B) as a guide to drill two 1/4" holes through mounting brackets (B/B). Secure both mounting brackets (B/B) together using a 1/4 x 1" button head bolt (G), 1/4" flat washer (D), and 1/4" hex nut (H) at each location. Tighten the 1/4" hex nut (H) until snug using a 7/16" wrench / or socket.

Reposition mounting brackets (B / B) and then re-check the toolbox (A) to make sure that it is level.

Use the existing holes in the bottom of mounting bracket (B) and mark the vehicle floor. Drill two 3/16" holes in the vehicle floor at the marked locations. Secure mounting brackets (B) to the vehicle floor using 1/4 x 1" black sheet metal screws (E) and 1/4" black flat washers (D). Tighten into place using a 7/16" wrench / or socket.

Now use the two existing holes in the top of mounting bracket (B) as a guide to drill two 1/4" hole through the bottom of toolbox (A). Secure the top of mounting bracket (B) to the side mount toolbox using a 1/4 x 1" Hex cap screw (G), 1/4" flat washer (D), and 1/4" hex nut (H). Tighten into place using a 7/16" wrench / or socket.

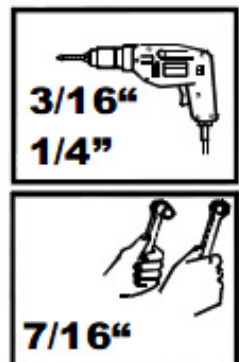
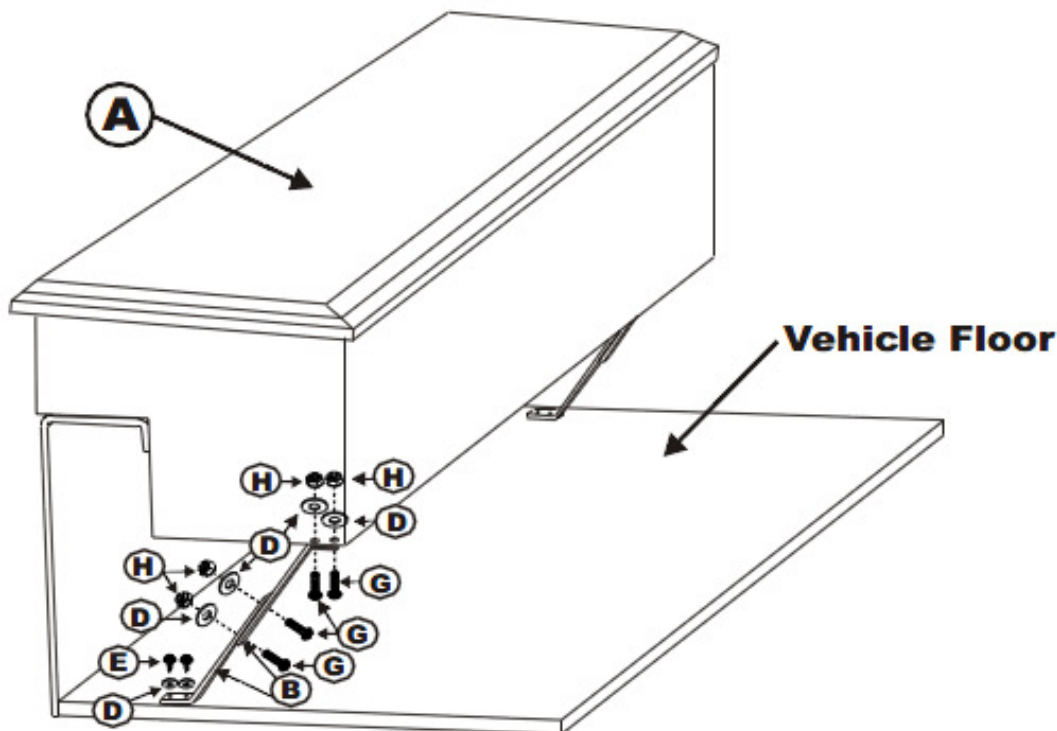

# TOOL BOX LATCH ADJUSTMENT

**NOTE: TOOL BOX LATCH WAS PRESET AT THE FACTORY. MAKE SURE THE LATCH IS ADJUSTED TO THAT OF YOUR DESIRED SEAL.**

**ALSO, PERIODIC ADJUSTMENT MAY BE NEEDED OVER TIME.**

**PLEASE REFER TO LATCH ADJUSTMENT INSTRUCTION BELOW.**

1. Keeping the striker plate perpendicular to the lid, adjust the striker location left and right to align the pin with the latch as shown below. The dot identified by the arrow shows the preferred location of the striker pin.

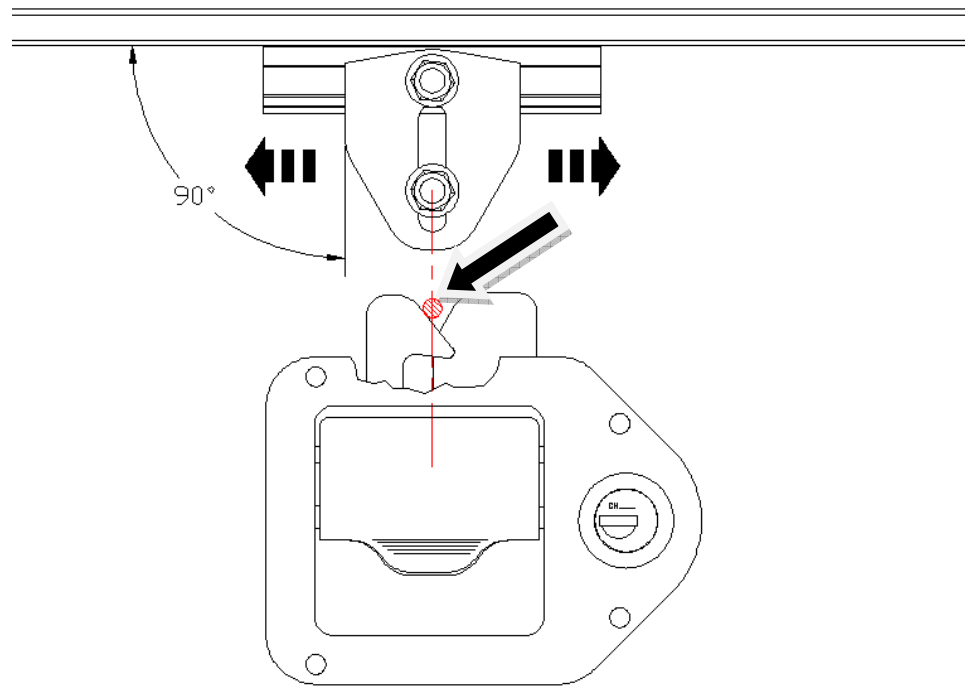

2. When the striker pin is correctly centered, tighten top bolt to set the location.

3. Set the pin depth to ensure that the head will clear the latch.

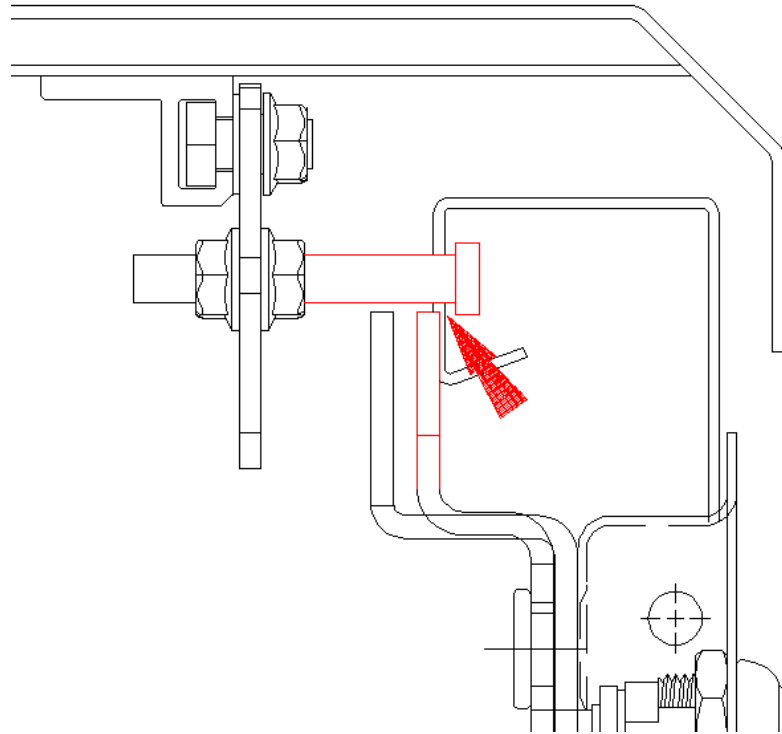

4. Tighten the pin in the lowest location, and close the lid. If the lid is able to move up and down when latched, the latch pin needs adjusted. Adjust the pin up the approximate amount the lid is able to move and retighten.

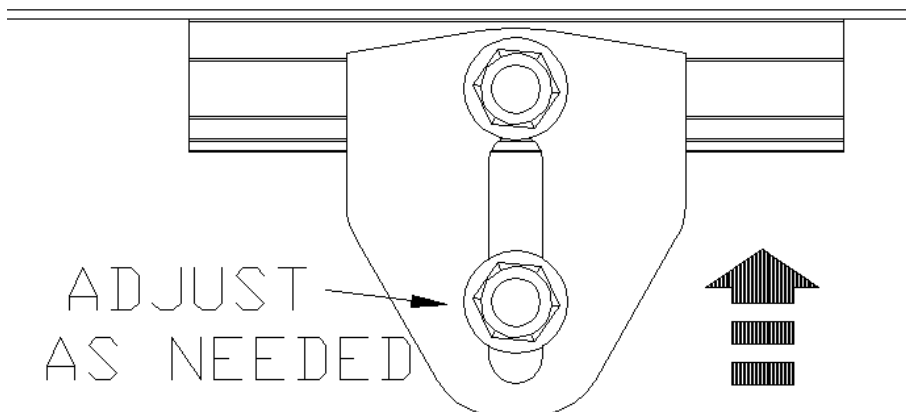
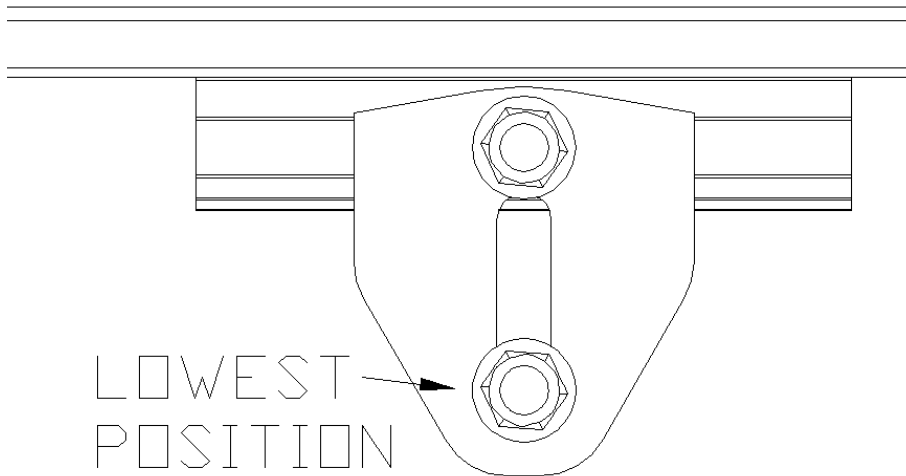

**MAINTENANCE INSTRUCTIONS:** All locks, latches, latching rods, and hinges should be lubricated regularly to assure smooth and proper operation for the life of the toolbox.

**INSTRUCTIONS D'Entretien:** Toutes les serrures, verrous, verrouillant des tiges, et des charnières devraient être lubrifiées régulièrement pour assurer l'exécution sans heurt et appropriée pendant la vie de la boîte à outils.

**Toolbox Paddle Latch Assembly**

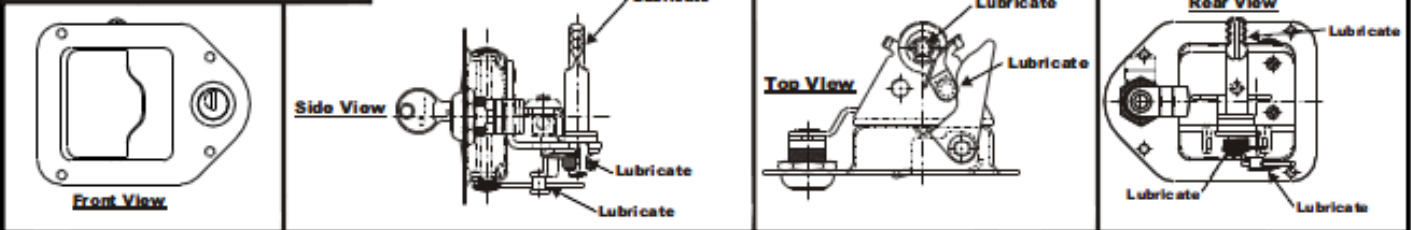

**Toolbox Catch Assembly**

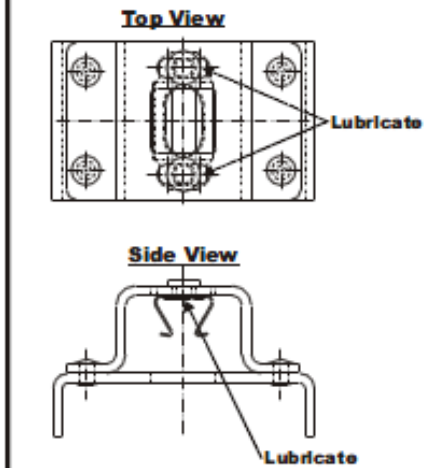

**Ever lose your keys? Save Yourself Time and Trouble?**

Order some extra keys now and have them when you need them. Please fill out and mail this portion to us.

Name: \_\_\_\_\_

Day Phone: \_\_\_\_\_ - \_\_\_\_\_ - \_\_\_\_\_

Address: \_\_\_\_\_  
 \_\_\_\_\_  
 \_\_\_\_\_

Method of Payment:

- Cash, Check, or Money Order
- Master Card
- Visa

City, State, Zip: \_\_\_\_\_

Expiration Date: \_\_\_\_\_

KEY and LOCK#: \_\_\_\_\_

Card Number: \_\_\_\_\_

**CLEANING INSTRUCTIONS:** To maintain the luster of your tool box, use a mild detergent.

\*\*Locks are provided as a deterrent to inadvertent opening or easy access to the contents of your toolbox. Contents stored in the toolbox are the responsibility of the user.

After drilling, it is recommended that a sealant or rust inhibitor be placed around all holes drilled into the body panel of the vehicle.



# Replacement Parts for Side Mount Toolbox

## Toolbox Hook-Paddle Latch Assembly

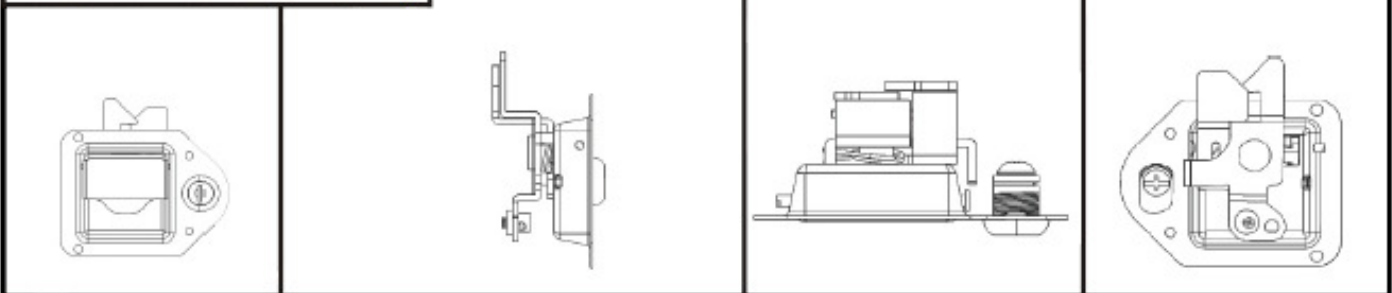



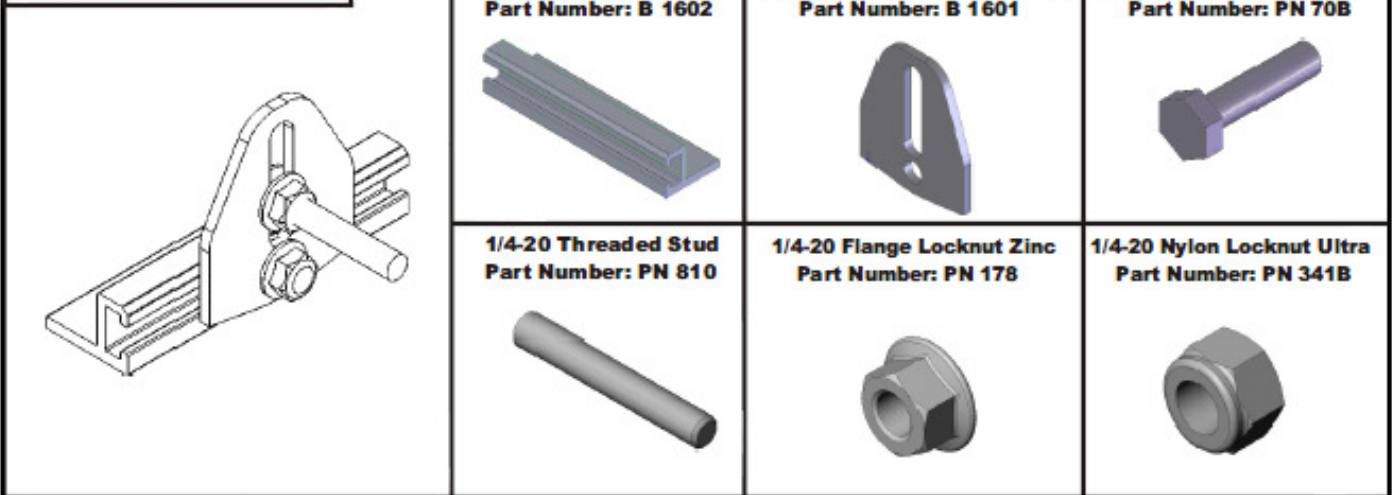



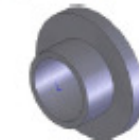



## Toolbox Hook-Catch Assembly



## Nylon Standoff Part Number: PN 860



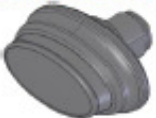
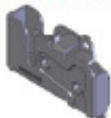

## Pushbutton - Blue Series





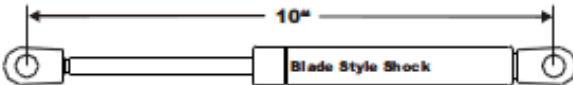
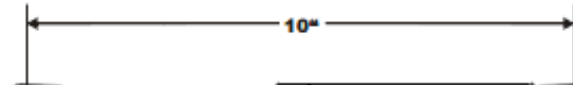
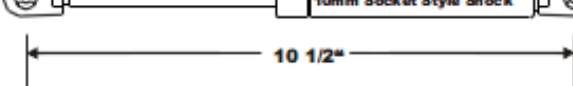

<p><b>Spacer Brace for Push Button</b> Part Number: B 1623</p> 	<p><b>Adjustable Latch</b> Part Number: B 1610</p> 	<p><b>Carburetor Clip 7R</b> Part Number: LCC-2</p> 	<p><b>Mounting Bracket</b> Part Number: B 1625</p> 
<p><b>Shock Mount</b> Part Number: SL-69</p> 	<p><b>Nylon Bushing</b> Part Number: PN 116</p> 	<p><b>5/16-18 Nylon Insert Locknut</b> Part Number: PN 510</p> 	<p><b>10 x 1/4 Square Pan Self Drill</b> Part Number: PN 872</p> 
<p><b>Push Latch</b> Part Number: TB 85623</p> 	<p><b>Rotary Latch</b> Part Number: TB 85624</p> 	<p><b>Rod End Adaptor</b> Part Number: TB 85626</p> 	



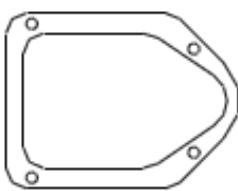

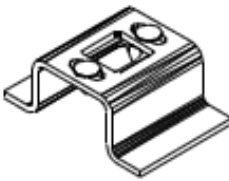

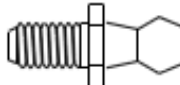

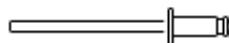

# Replacement Parts for Side Mount Toolbox Cont.

## Shocks

 <p>Blade Style Shock</p>	<b>Blade Style Shock</b>				
	Shock #	20#	40#	70#	
Part Number	SL1-20	SL1-40	SL1-70		
 <p>10mm Socket Style Shock</p>	<b>10mm Socket Style Shock</b>				
	Shock #	20#	40#	70#	
Part Number	SL-3020	SL-3040	SL-3070		
 <p>10mm Socket Style Shock</p>	<b>10mm Socket Style Shock</b>				
	Shock #	20#	40#	60#	80#
Part Number	SL-3220	SL-3240D	SL-3260D	SL-3280D	SL-32100D
 <p>10mm Socket Style Shock</p>	<b>10MM Socket Style "Long" Style Shock</b>				
	Shock #	90#	40#		
Part Number	SL-3390	SL-3340			

## Miscellaneous Parts

<b>Foam Latch Gasket</b> Part Number: TB85409 	<b>Shock Clip</b> Part Number: SL-81 	<b>Striker Assembly</b> Part Number: TB85616 	<b>Shock Mount Nut</b> Part Number: PN 301 	<b>Latch Cover Rivet</b> Part Number: PN 285 
	<b>Shock Mount</b> Part Number: SL-69 			<b>Latch Rivet</b> Part Number: PN 157 
				<b>Hinge Rivet</b> Part Number: PN 762 

<b>Rod Clip</b> Part Number: LCC-1 	<b>Rod Guide</b> Part Number: TB85615 	<b>1/4" Flat Washer</b> Part Number: PN 72B Black 	<b>1/4 x 1" Sheet Metal Screw</b> Part Number: PN 97B Black 	<b>1/4 x 1" Sheet Metal Screw</b> Part Number: PN 97 	<b>1/4 x 1" Bottom Head Screw</b> Part Number: PN 96B 
	<b>1/4" Locknut</b> Part Number: PN 341B 	<b>Mounting Bracket</b> Part Number: TBTRACE1 	<b>Divider Mounting Channel</b> Part Number: TB-Channel 	<b>Toolbox Divider</b> Part Number: TB-Divider 	<b>Toolbox Divider Tape</b> Part Number: CO-tape 

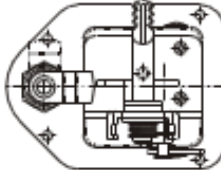
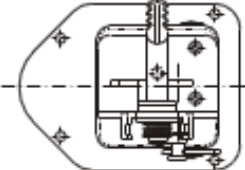
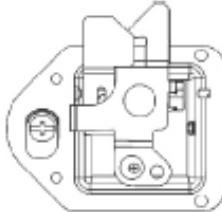
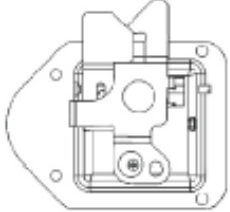
<b>Rear View: Locking Latch</b> Part Number: TB85613 	<b>Rear View: Non-Locking Latch</b> Part Number: TB85614 	<b>Rear View: Locking Hook</b> Part Number: Tb85608 	<b>Rear View: Non-Locking Hook</b> Part Number: Tb85608 
--	--	---	---