



**Installation Instructions:  
MT6 / MT8**

**TOYOTA TACOMA  
6'2" BED LENGTH**

**MT6 2005-2018 / MT8 2019-CURRENT**

**TOOLS REQUIRED**

- Adjustable wrench (that opens to about 1")
- 1/2" open end wrench
- #2 Phillips screwdriver,
- Short 7/32" hex wrench
- 7/16" deep socket
- 3/8" socket
- Electric drill
- 9/64" drill bit
- 1/4" drill bit
- 5/16" drill bit
- Drill stop
- T40 Torx Driver

# CONTENTS

## DECKED carton

- LEFT deck half - 1
- RIGHT deck half - 1
- Center vert - 1
- Cabside vert - 1
- Drawer - 2
- Left ammo can - 1
- Right ammo can - 1
- Left stud - 1
- Right stud - 1
- Ammo can lid - 2
- C-channel - 2
- Ruler - 1
- Hardware box - 1
- Torsion brace - 1

## Hardware box - unbagged components

(inside DECKED carton):

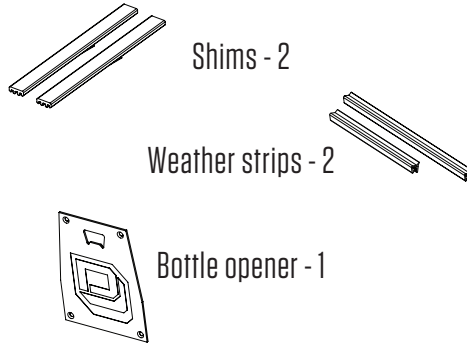

## HARDWARE box - bagged components

- PREP-MT6 or MT8 - 1
- S1 - 1
- S2 - 1
- N1 - 1
- J5 - 2
- DRAWER 1 - 1
- DRAWER 2 - 1
- WHEELS - 1
- FINAL MID - 1
- PREP-EXTRA - 1
- MS WASHERS - 1
- (MT8 ONLY) TACOMA TD - 1

## ASSEMBLY OVERVIEW

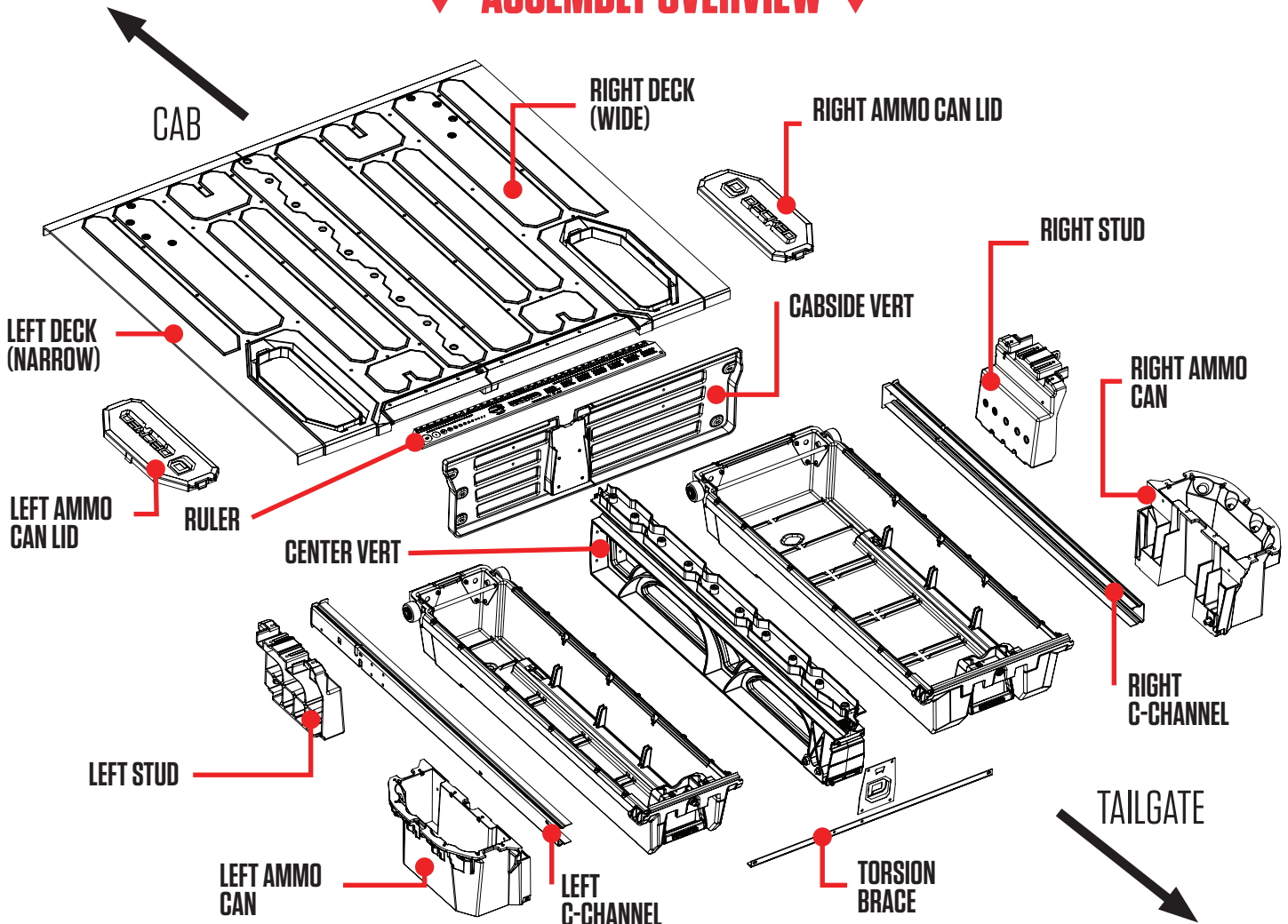

## ▼ HEY! TORQUE BOY: READ BEFORE YOU INSTALL DECKED ▼

1. **DON'T** over tighten bolts, get em' good 'ole hand-tight.
2. **DON'T** use power tools.
3. If you don't follow directions and do use power tools:
  - 1). Set clutch at a very low setting.
  - 2). Don't blow it.
  - 3). If you blow it, see NOTE.\*

**NOTE\*** Two extra threaded inserts are included in BAG **PREP-EXTRA**. That's all you get.

- 4). **DON'T** over tighten J-hooks during installation. Make 'em good and snug enough to keep the system from moving in the bed.
- 5). Start all bolts with fingers to avoid cross-threading.

**NOTE:** In your BAG **PREP-MT6** or **MT8**, you will have two types of 1" length bolts and flanged nuts. One bolt has a 1/4" diameter, and the other bolt has a 5/16" diameter. Don't screw this up! The flanged nuts only fit one type of bolt, so you better at least get that right...

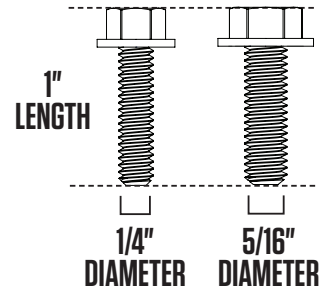

## PREP BED: MARK CENTER OF BED

- Use a marking pen or wax pencil to mark the center of the bed (blue) on the raised bead.

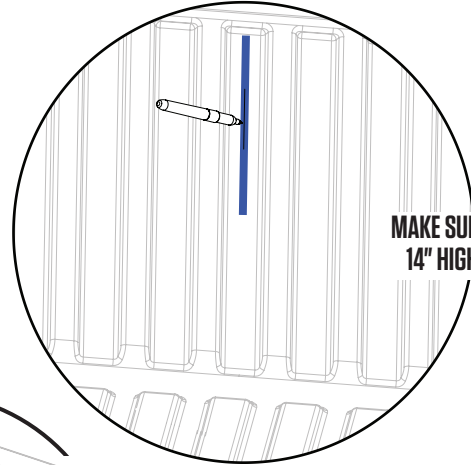

**MAKE SURE MARK SITS AT LEAST 14" HIGH (SO YOU CAN SEE IT)**

### DETAIL A

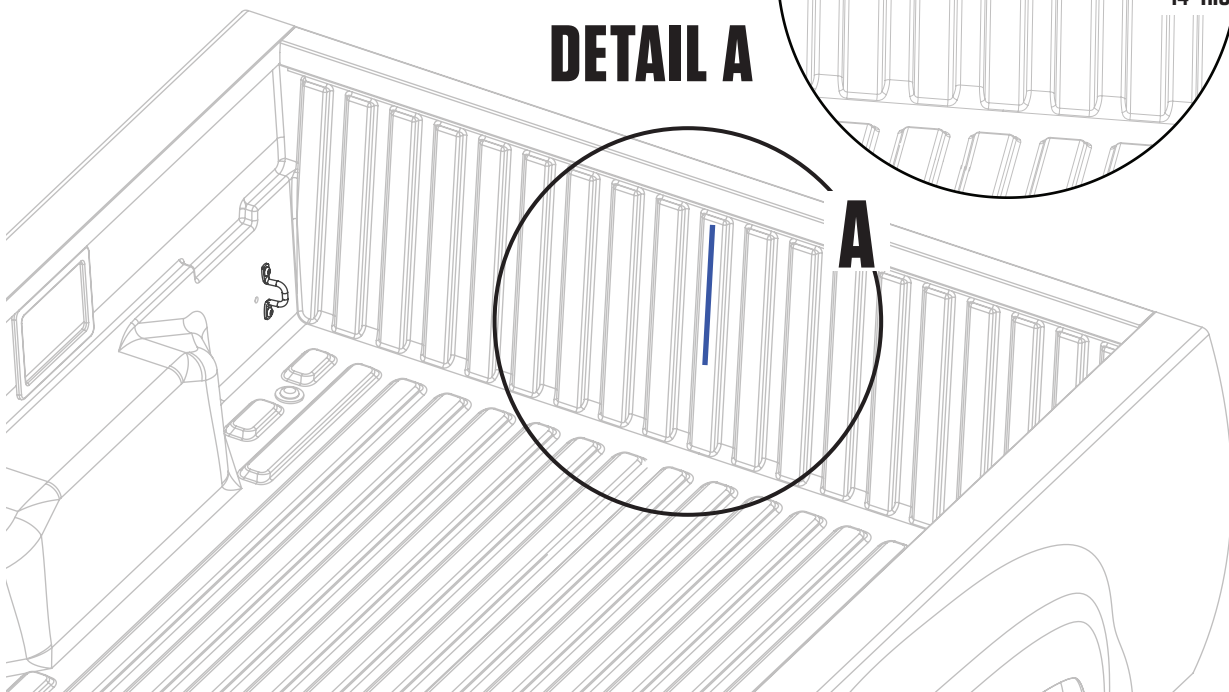

# PREP BED: SHIMS

- **2 SHIMS** that look like this can be found in your hardware kit.
- Using the information below:
  - 1) Clean the bed surface where the shims will be located. Isopropyl alcohol (do not drink) is recommended.
  - 2) Remove tape film and apply shim with the strength of 1000 men a.k.a push really hard.

## DETAIL B

Align shim to channel in floor shown. Place shim 8" from rear of bed (edge in red).

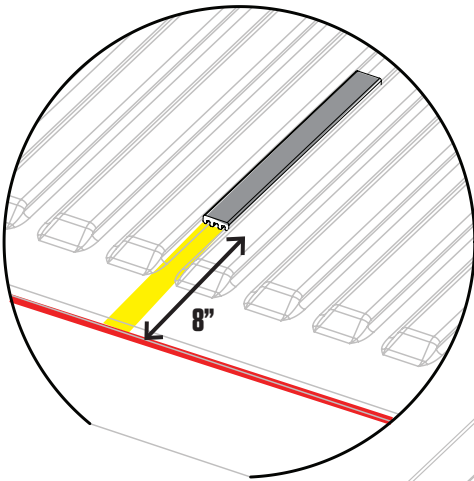

## DETAIL A

Align shim to channel in floor shown 3" from cabside panel of bed (edge in red).

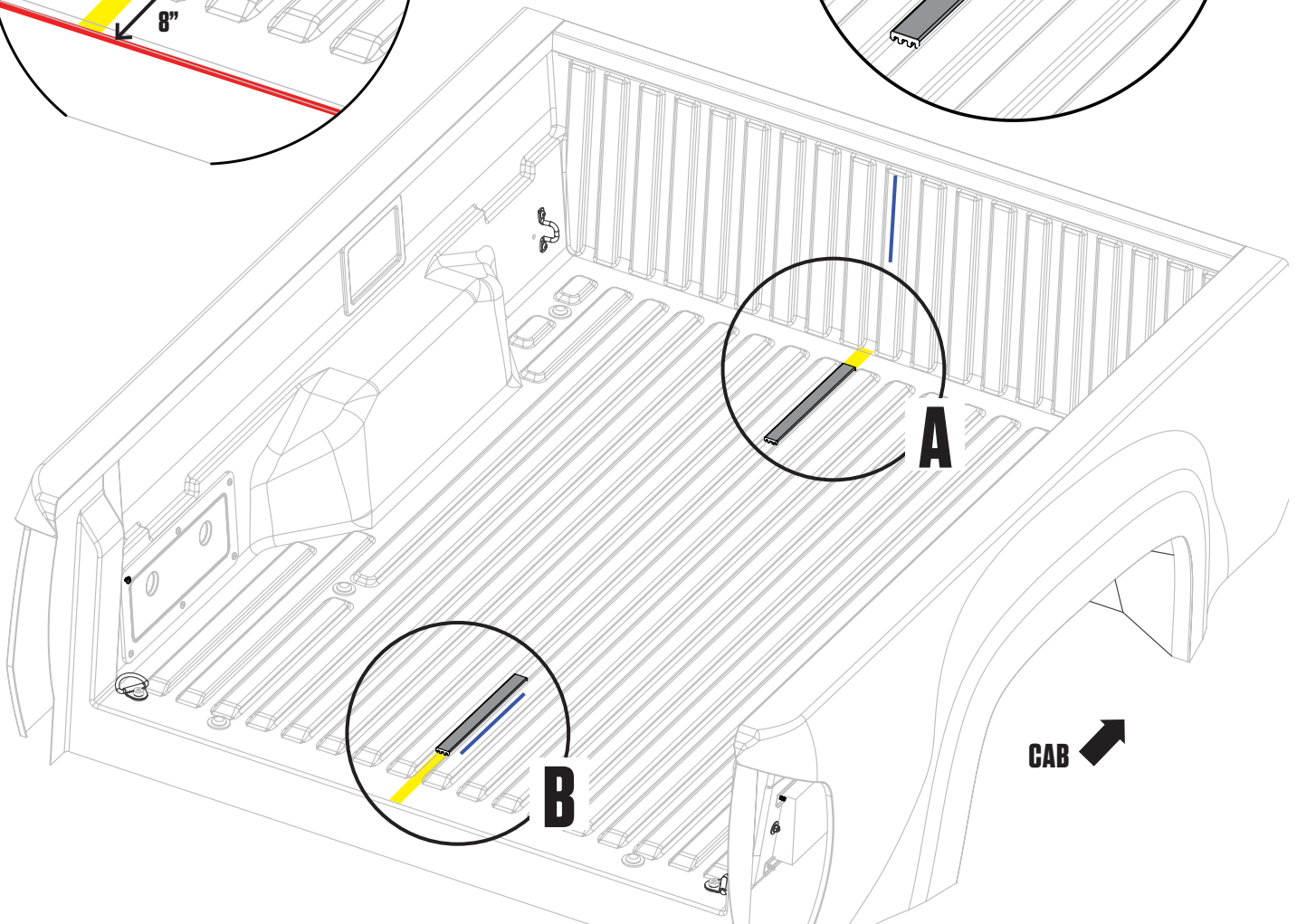
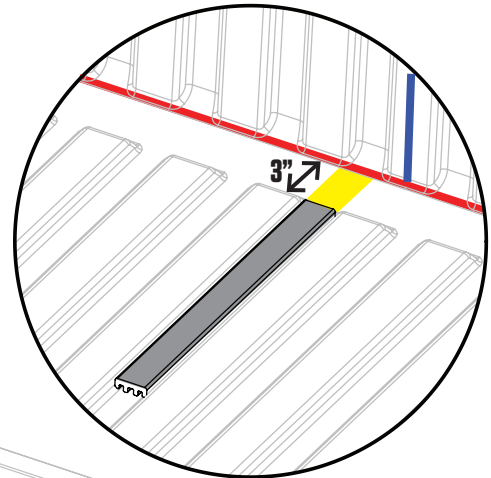





**Do you have a factory cabside tie down?**

**NO: GO TO PAGE 6**

**YES: GO TO PAGE 7**

# STOP:

Double check that you have a Tacoma without a cabside factory tie-down. If you have a model with a cabside factory tie-down (you're stoked!), go directly to page 7.

## PREP BED: CABSIDE BRACKET

- Follow STEP 1 - STEP 4; BAG PREP-MT6 or MT8.
- Repeat passenger side.

**RECOMMENDED TORQUE:**

**Bolts in labeled bag PREP-MT6 or MT8 - 27 in-lb.**

### STEP 1

Mark bottom hole location (blue) at 2 1/2" up from floor and 4" from cabside panel of bed. Mark top hole location (red) 2 3/4" up from bottom hole and 4" from cabside panel.

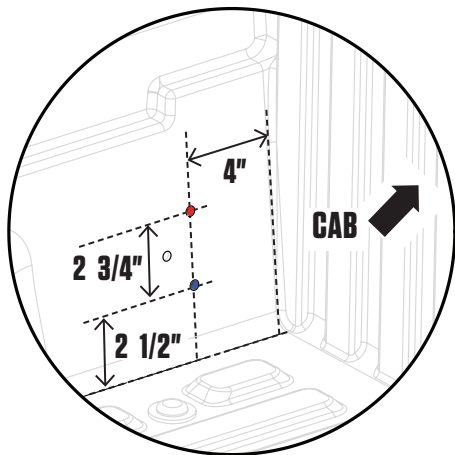

### STEP 2

Mark center hole (green) 1 3/8" up from lower hole center. Mark 1 1/8" toward tailgate from top hole center.

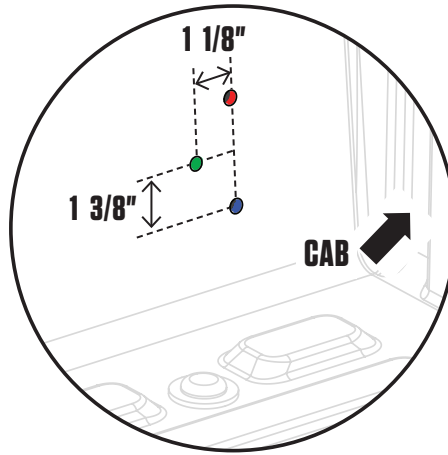

### STEP 3

At all three mark locations, drill a 5/16" hole using a 1/2" drill stop.



### STEP 4

Play Rock Paper Scissors with your pal. The loser needs to hold the backing plate inside the wheel well. Grab three 1" length x 5/16" diameter bolts and place two through the oval cabside bracket holes and one through the round tailgate side hole bracket. Install through backing plate holes shown (green). Securely tighten with flanged nuts.

**BACKER PLATE GOES OUTSIDE THE INNER PLASTIC BED ON THE INTERIOR WHEEL WELL WALL... TRY SAYING THAT THREE TIMES FAST.**

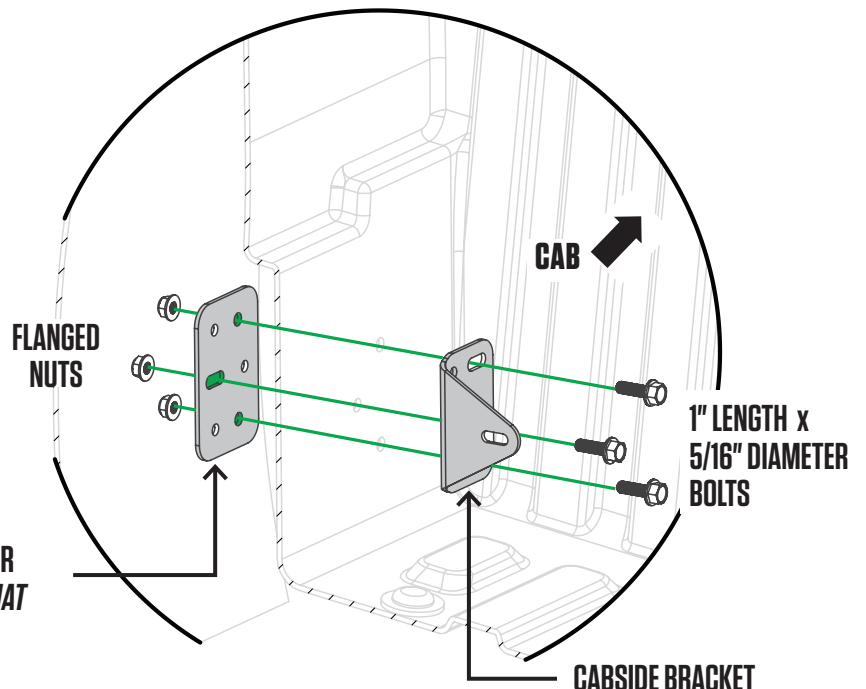

**NOTE: Do not attempt alone. Rock Paper Scissors for who lays on the ground to hold the backing plate.**

# STOP:

Double check that you have a Tacoma with a cabside factory tie-down. If you don't have a cabside factory tie-down, revert to page 6.

## PREP BED: CABSIDE BRACKET

- Follow STEP 1 - STEP 2; BAG PREP-MT6 or MT8.
- Repeat passenger side.

**RECOMMENDED TORQUE:**

**Bolts in labeled bag PREP-MT6 or MT8 - 27 in.-lb.**

**STEP 1** Remove factory cabside tie-down with a T40 torx driver. Keep bolts. Mark  $1\ 3/8"$  up from lower factory hole center. Mark  $1\ 1/8"$  toward tailgate from factory hole centers. At center mark (green), drill a  $5/16"$  hole using a  $1/2"$  drill stop.

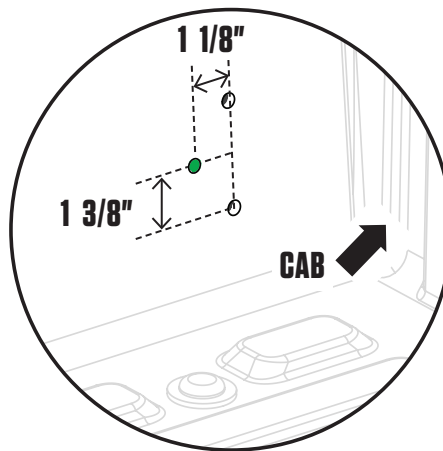
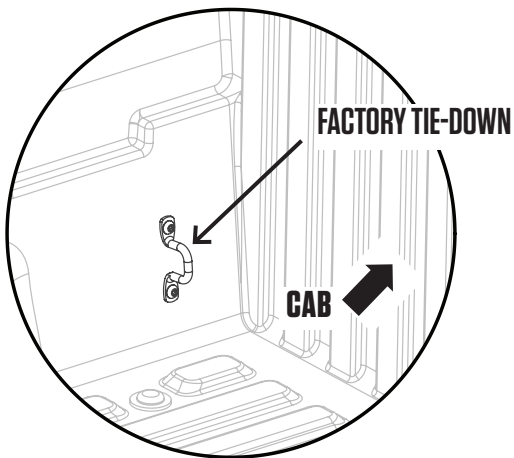

### STEP 2

Install cabside bracket with the two factory tie-down bolts inserted in the oval holes. Play Rock Paper Scissors with your pal. The loser needs to hold the backing plate inside the wheel well. Install one 1" length x  $5/16"$  diameter bolt through center cabside bracket hole into backing plate and install with flanged nut. **NOTE: You'll have four extra 1" bolts and four nuts that you won't need in your MT6 or MT8 bag. Do with them as you wish.**

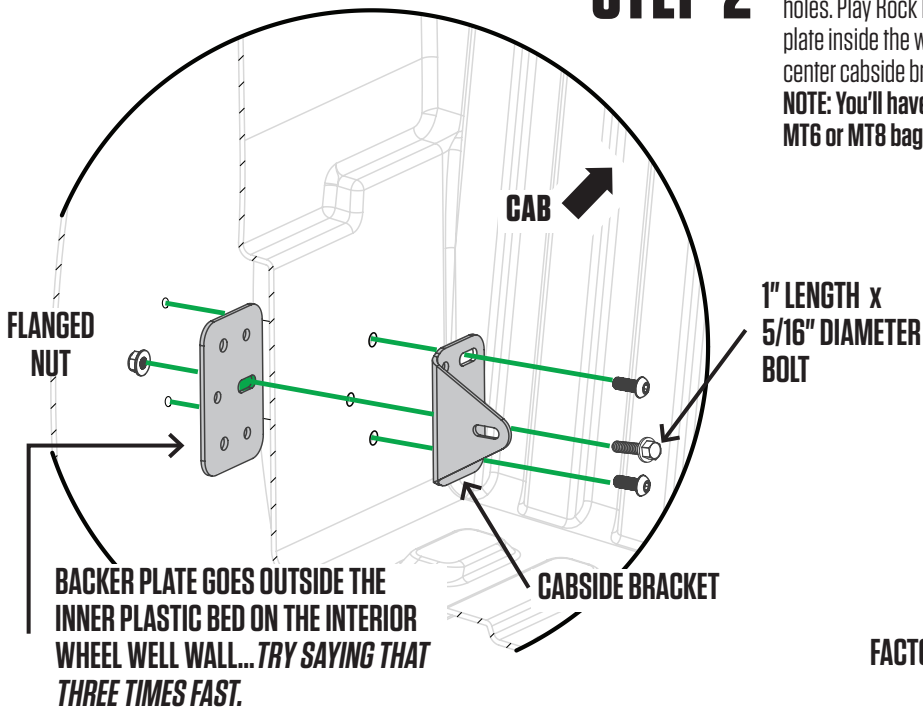

### VIEW FROM WHEEL WELL

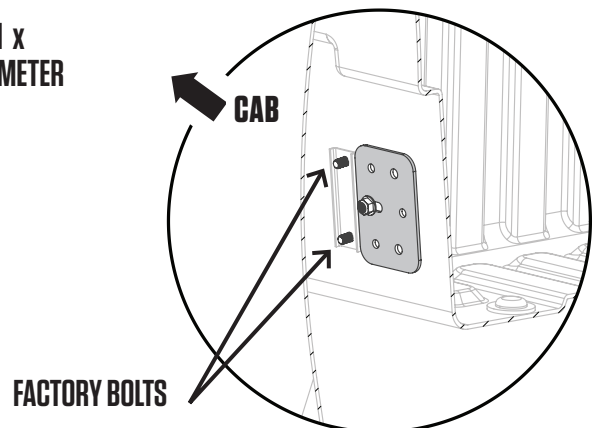

**NOTE: Do not attempt alone. Rock Paper Scissors for who lays on the ground to hold the backing plate.**

# PREP BED: TAILGATE BRACKET

**NOTE:** You will need to grab a pal for this step (or have incredibly long and flexible arms).

- Remove top rear factory compartment bolt from the passenger side with a T40 Torx Driver. Keep bolt.
- Loosely attach passenger side tailgate bracket with factory bolt in top hole. Make sure the tie down opening is angled toward the driver, not the tailgate; **BAG PREP-MT6 or MT8.**
- Align bracket so it's parallel with vertical edge of compartment. Tighten factory bolt at last!
- Using the bottom hole in bracket as a guide, drill a 5/16" hole with a 1/2" drill stop through compartment and bed wall.
- Install a 1" bolt through the bracket and bed wall. Install 1" washer and flanged nut and tighten securely; **BAG PREP-MT6 or MT8.**
- Repeat driver side unless you don't have a driver's side cubby. If not, follow the instructions for driver's side on next page. **NOTE: On passenger side ONLY, you will need to add a washer; BAG PREP-MT6 or MT8...**  
**We know it's strange, trust us.**

## DRIVER SIDE

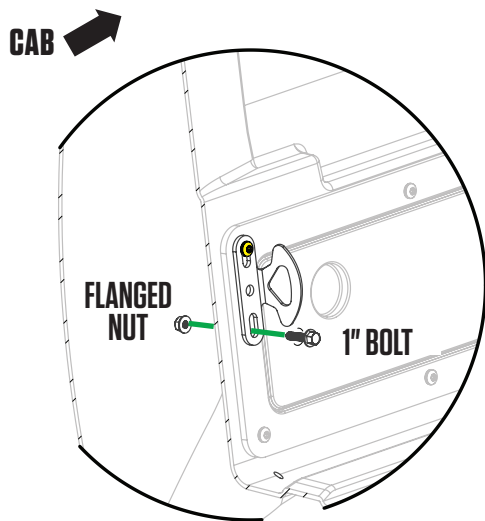

## PASSENGER SIDE

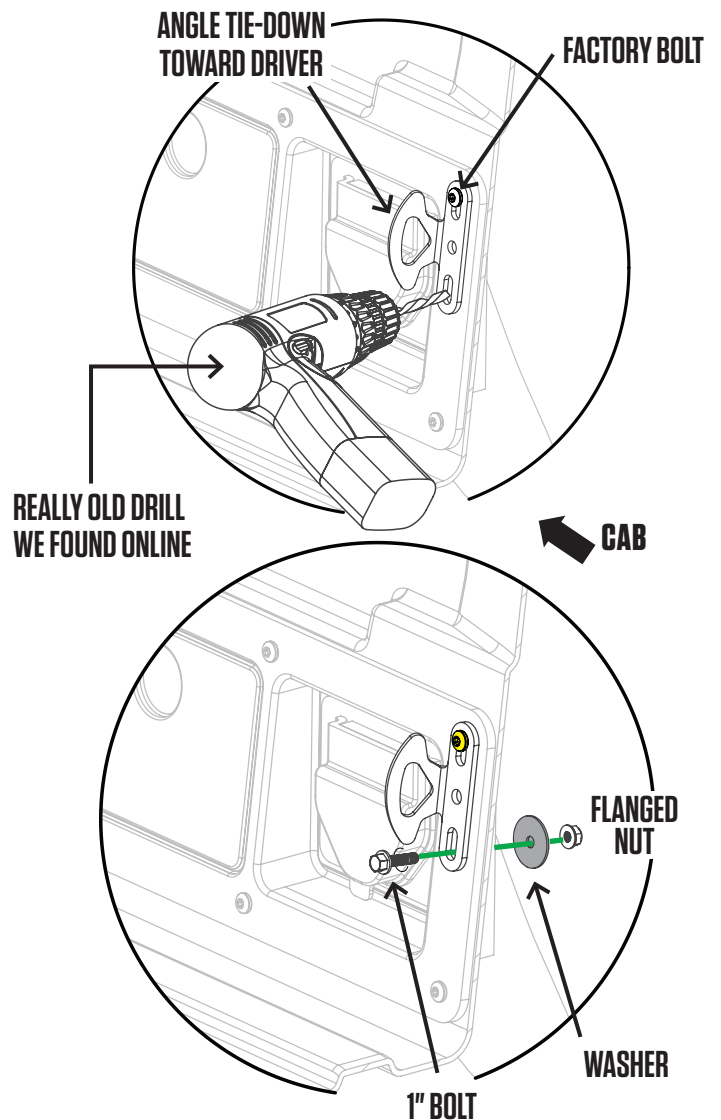

### RECOMMENDED TORQUE:

Bolts in labeled bag PREP-MT6 or MT8 - 53 in-lb.

**HELPFUL TIP:** Feel free to remove doors of cubbies so you can still somewhat use them. Use will be compromised, but hey, life ain't always fair, right?!

**HELPFUL TIP:** The power outlet can still be used if you insert a flat head pigtail extension cord **BEFORE** you install the decks. Make sure to have the outlet capped to keep water out.

# PREP BED: TAILGATE BRACKET

(FOR TACOMAS WITH NO DRIVER SIDE TAILGATE CUBBY)

**NOTE:** Disregard this page if you **HAVE** a driver's side tailgate cubby.

- Referencing dimensional info in **DETAIL A** mark hole locations and drill (2) 5/16" holes (with drill stop set at .62").
- Referencing **DETAIL A** install J-hook mounting bracket as shown with bolts, backing plate and nuts.  
**Tighten bolts securely.** BAG PREP-MT8, BAG TACOMA TD.

## DETAIL A

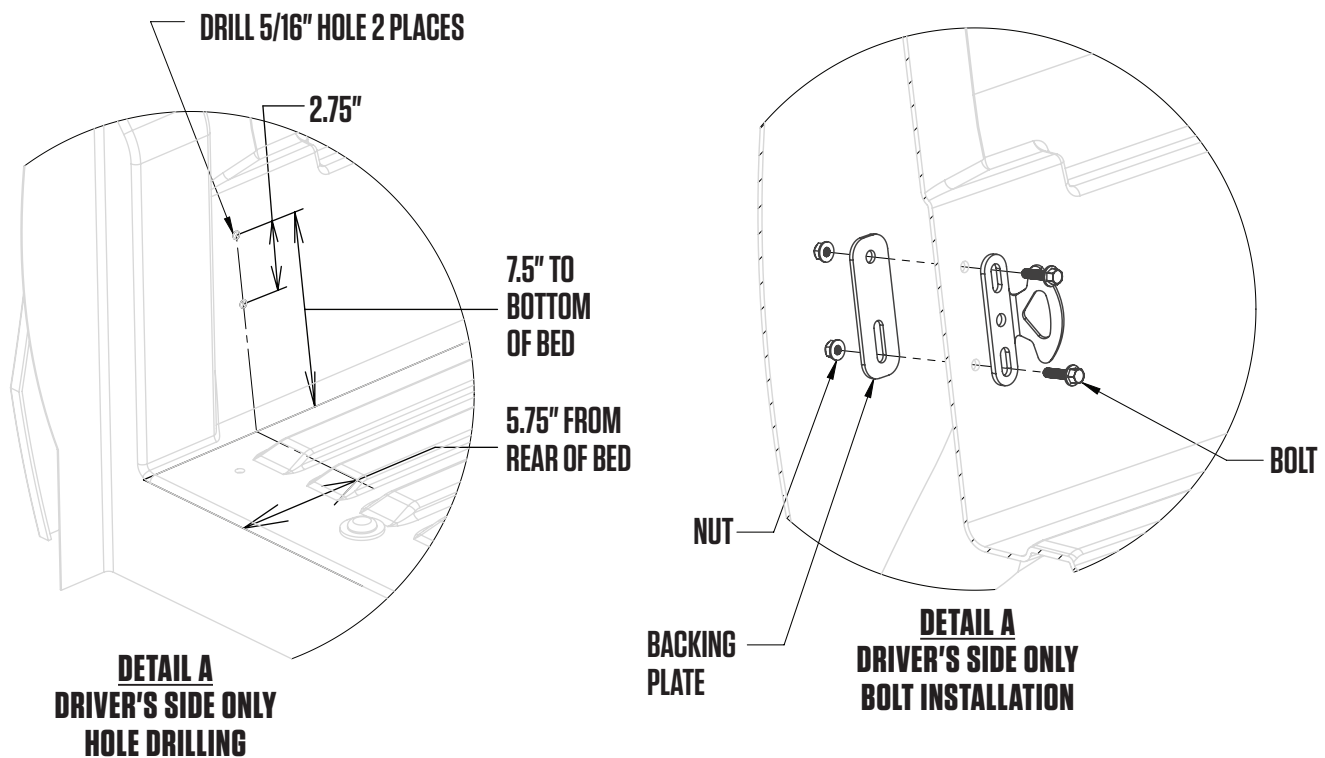

**RECOMMENDED TORQUE:**  
Bolts in labeled bag PREP-MT8 - 53 in-lb.

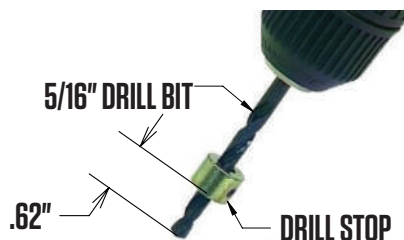

# ASSEMBLY: CENTER VERT + CABSIDE VERT

**NOTE:** Perform the next few steps on a flat surface like a garage floor.

- Attach center vert to cabside vert with four bolts. Alternate to tighten; BAG S1.

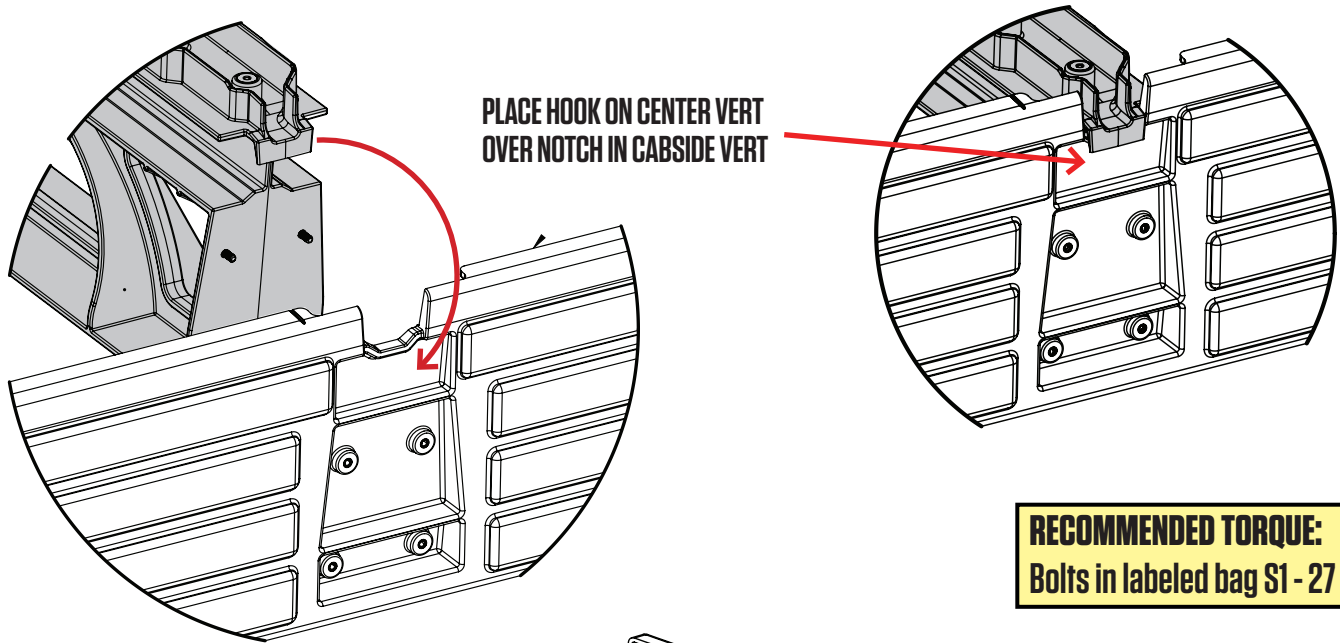

**RECOMMENDED TORQUE:**  
Bolts in labeled bag S1 - 27 in-lb.

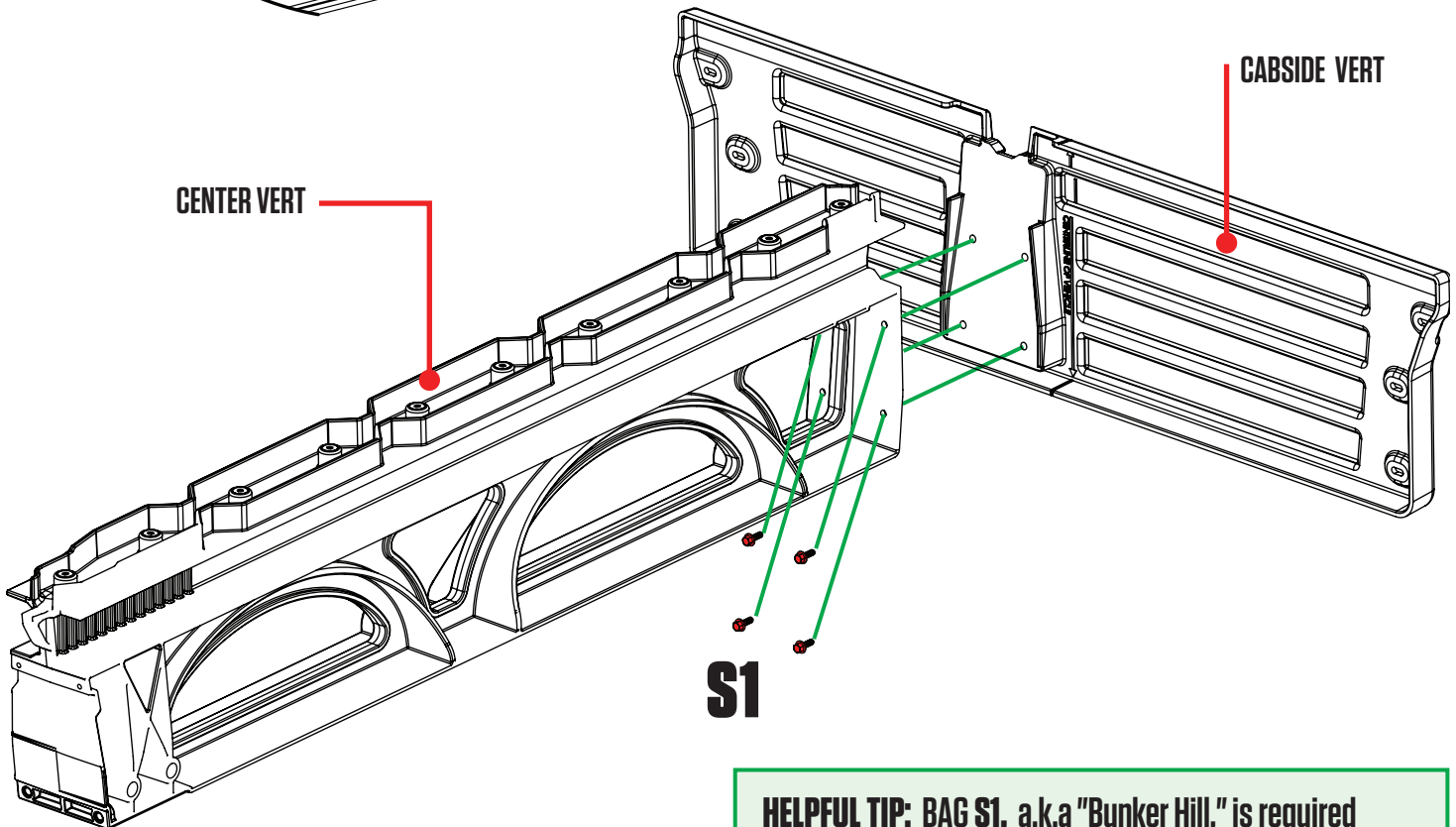

**HELPFUL TIP:** BAG S1, a.k.a "Bunker Hill," is required for most of the steps, so keep it close! These bolts are highlighted throughout instructions in **RED**.



# ASSEMBLY: LOOSELY ATTACH STUDS (YUP)

- **LOOSELY** attach studs to cabside vert with six bolts; **BAG S1**.

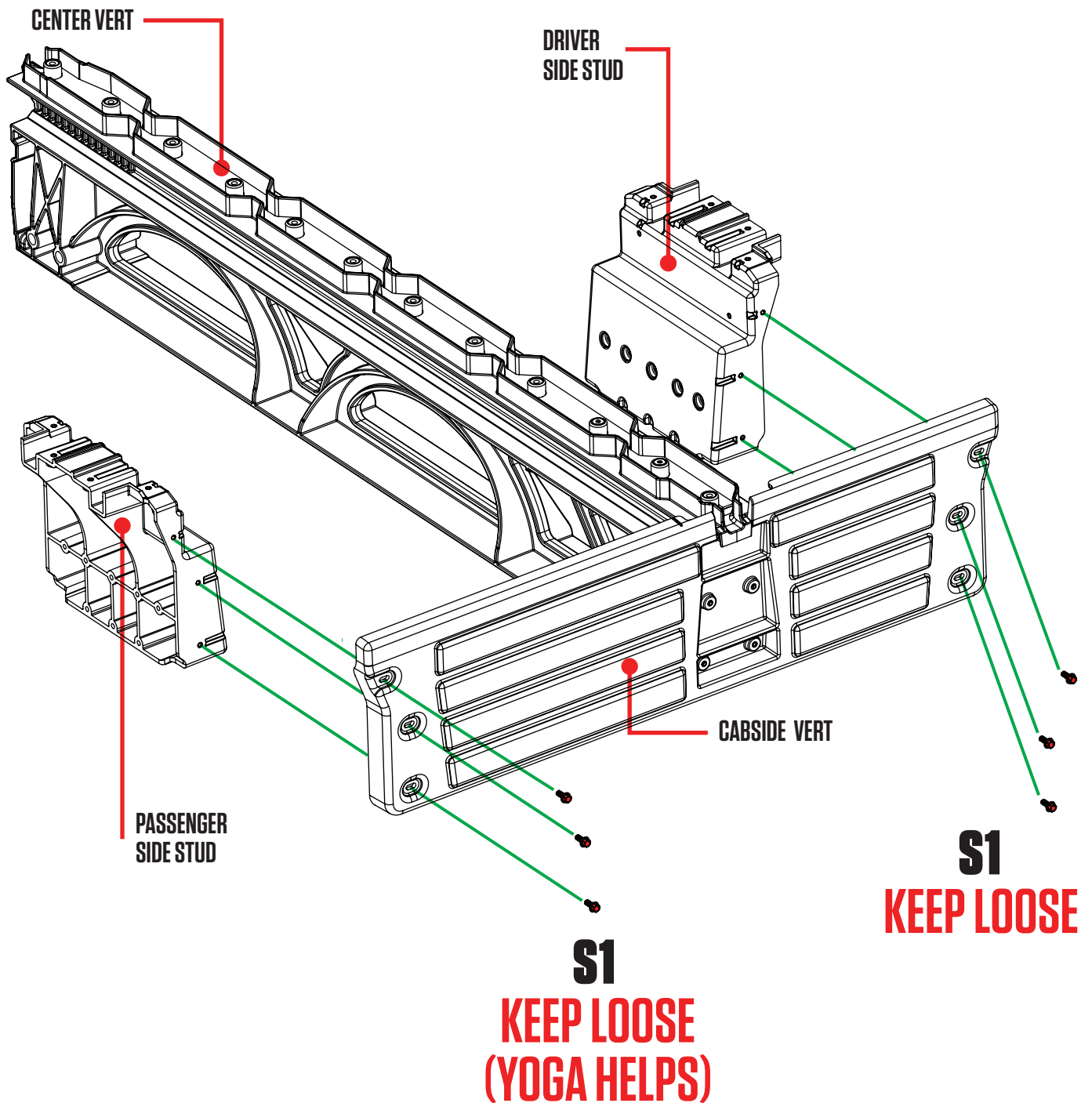

# ASSEMBLY: ALIGN & TIGHTEN STUDS (YUP)

**NOTE:** This step ensures the studs are properly located before tightening bolts. It's important.

- Place ammo cans to support tailgate end of deck panels.
- Lift deck panels on center vert + stud + cabside vert assembly.
- Slide studs around L-R until deck panels are seated.
- **DETAIL A:** Loosely secure four bolts to hold decks onto studs; **BAG S1**.
- Now you can securely tighten the bolts that hold the studs to the cabside vert.
- Unbolt deck from studs, remove deck panels, save bolts, remove ammo cans and set aside for later assembly.

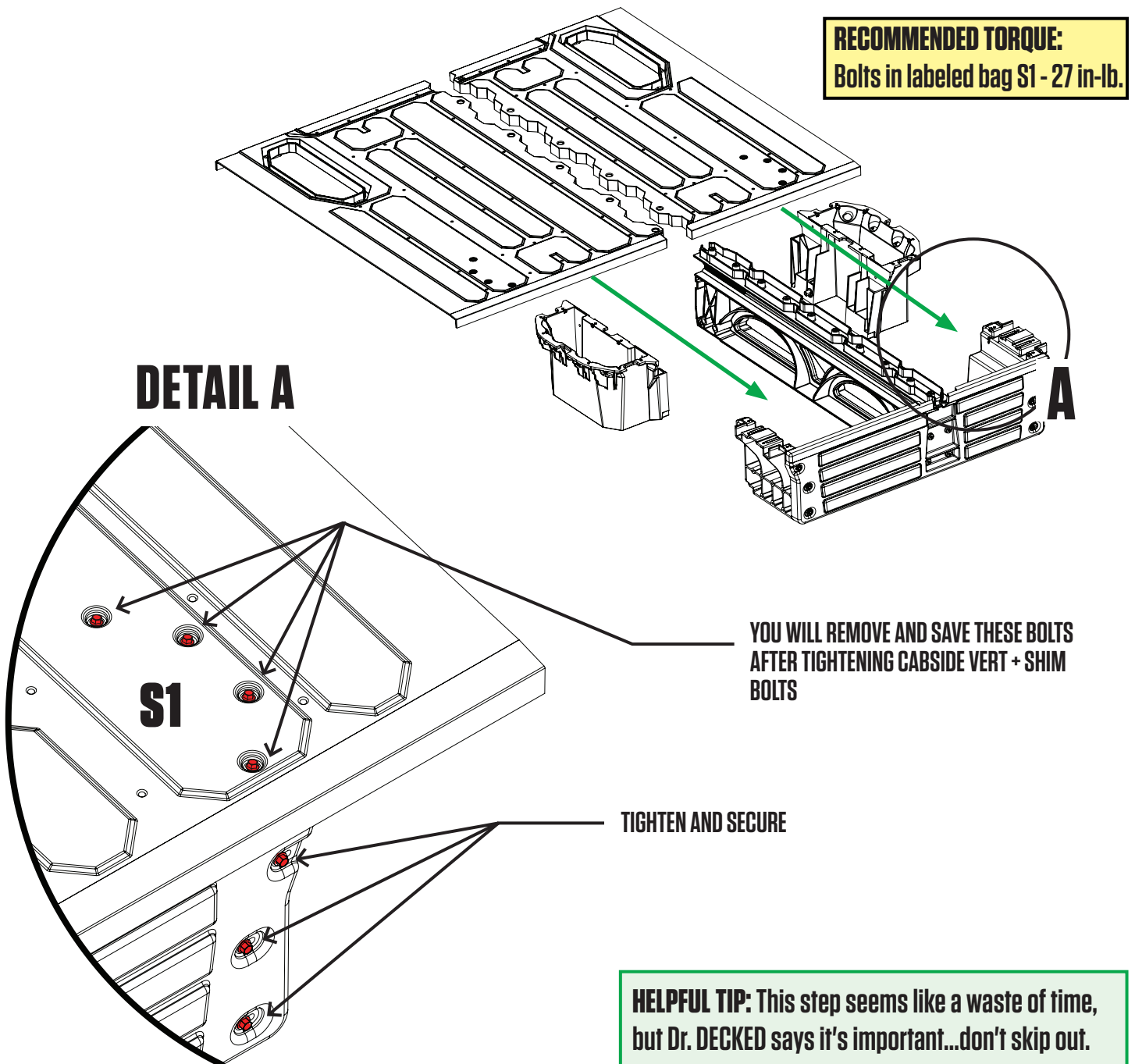

# ASSEMBLY: STUD BRACKETS

- **DETAIL A:** Securely attach stud bracket to driver side stud using three 3 1/2" length bolts and flanged nut in holes shown; BAG PREP-MT6 or MT8.
- **DETAIL B:** Securely attach stud bracket to passenger side stud using three 3 1/2" length bolts and flanged nut; BAG PREP-MT6 or MT8.

## DETAIL A

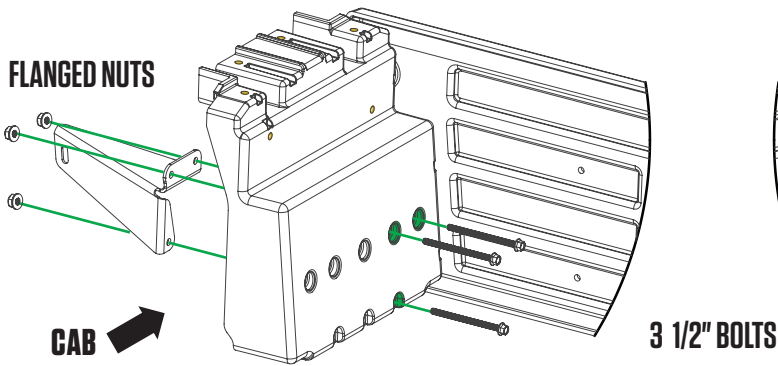

## DETAIL B

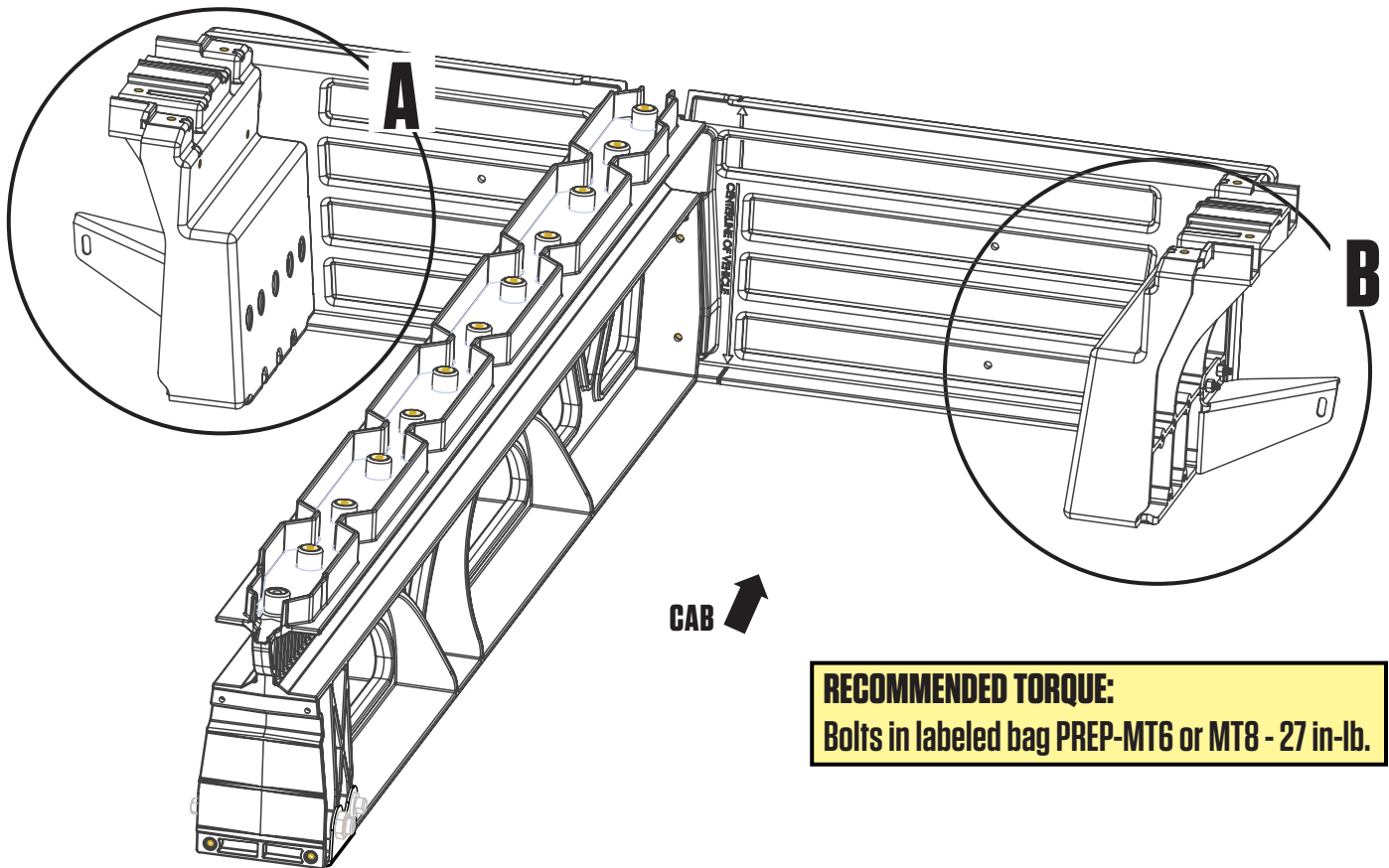
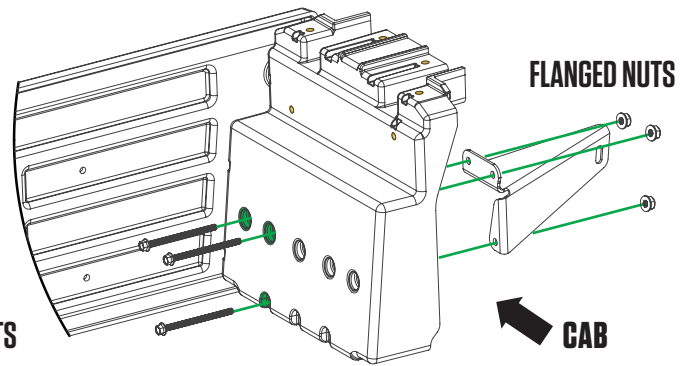

**RECOMMENDED TORQUE:**  
Bolts in labeled bag PREP-MT6 or MT8 - 27 in-lb.

# INSTALL: MOUNTING + CABSIDE ATTACHMENT

- While supporting both ends, lift center vert + stud + cabside vert assembly in truck bed. Position against cabside panel of bed with stud bracket **cabside** of cabside bracket.
- **DETAIL A:** Install a 3/4" length bolt and flanged nut and tighten securely; BAG PREP-MT6 or MT8.
- Repeat passenger side.

**RECOMMENDED TORQUE:**  
Bolts in labeled bag PREP-MT6 or MT8 - 53 in-lb.

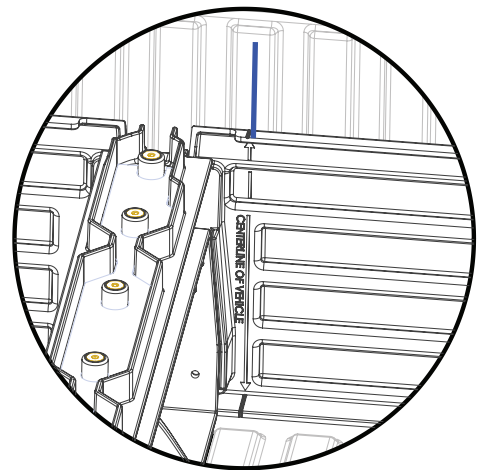
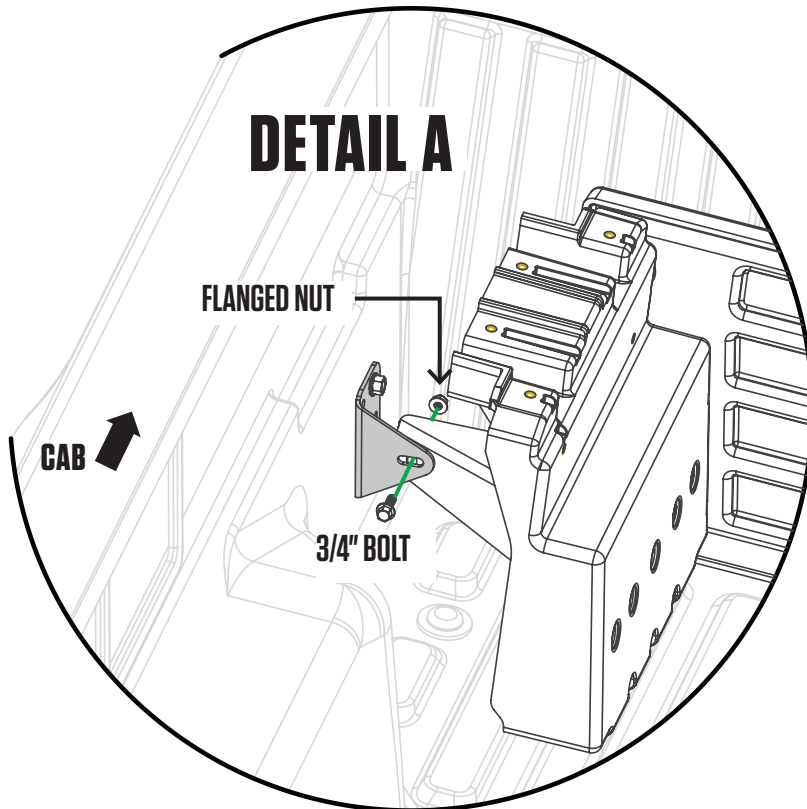

**NOTE:** Make sure centerline arrows on cabside vert are aligned with your centerline mark (blue).

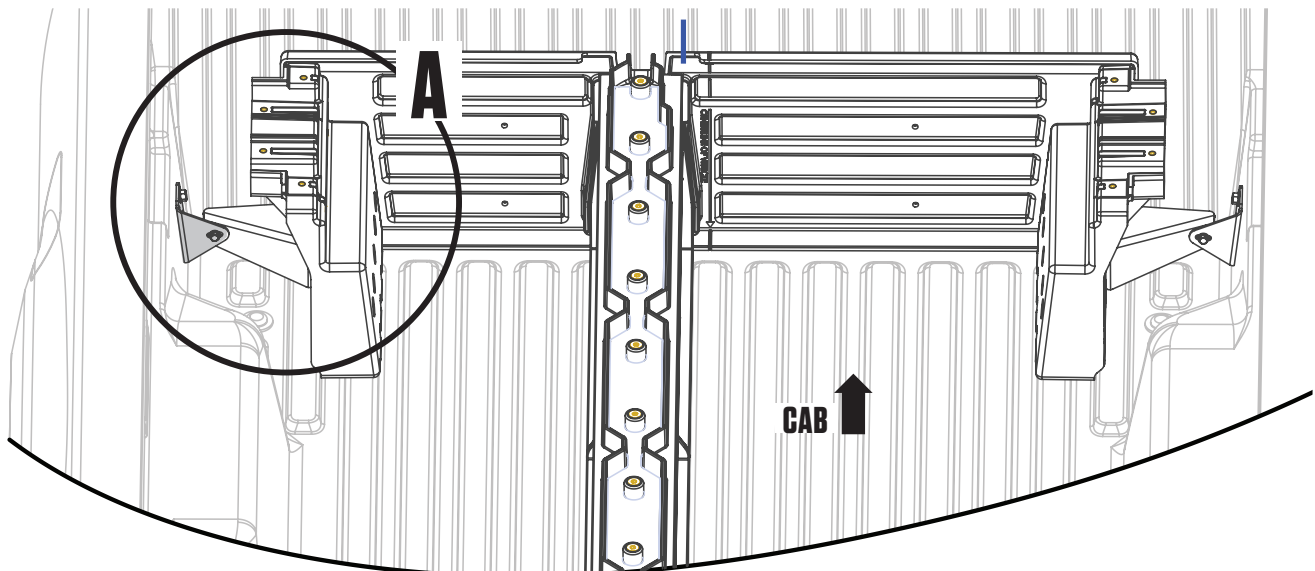

# INSTALL: C-CHANNEL

- Loosely place driver side ammo can at tailgate corner of bed. **The axles should be on the tailgate side of the truck.**
- Place driver side C-channel on ledge of stud and ammo can with end plate cabside.
- **DETAIL A:** Insert two bolts through C-channel into ammo can and **loosely** fasten with nut; **BAG S2, BAG N1.**
- **DETAIL B:** Tightly attach C-channel to stud; **BAG S1.**
- Repeat passenger side.

**RECOMMENDED TORQUE:**  
Bolts in labeled bag S1 - 27 in-lb.

## DETAIL A KEEP LOOSE

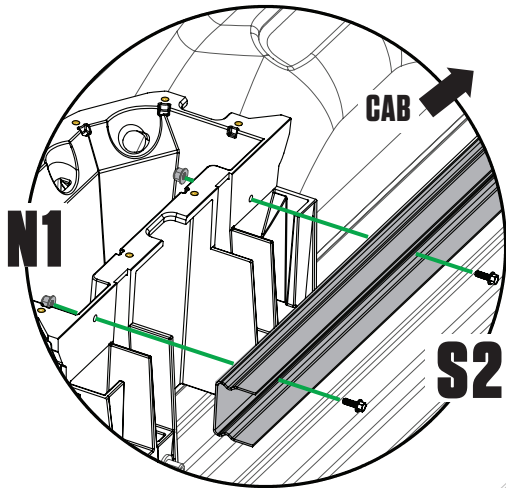

## DETAIL B TIGHTEN

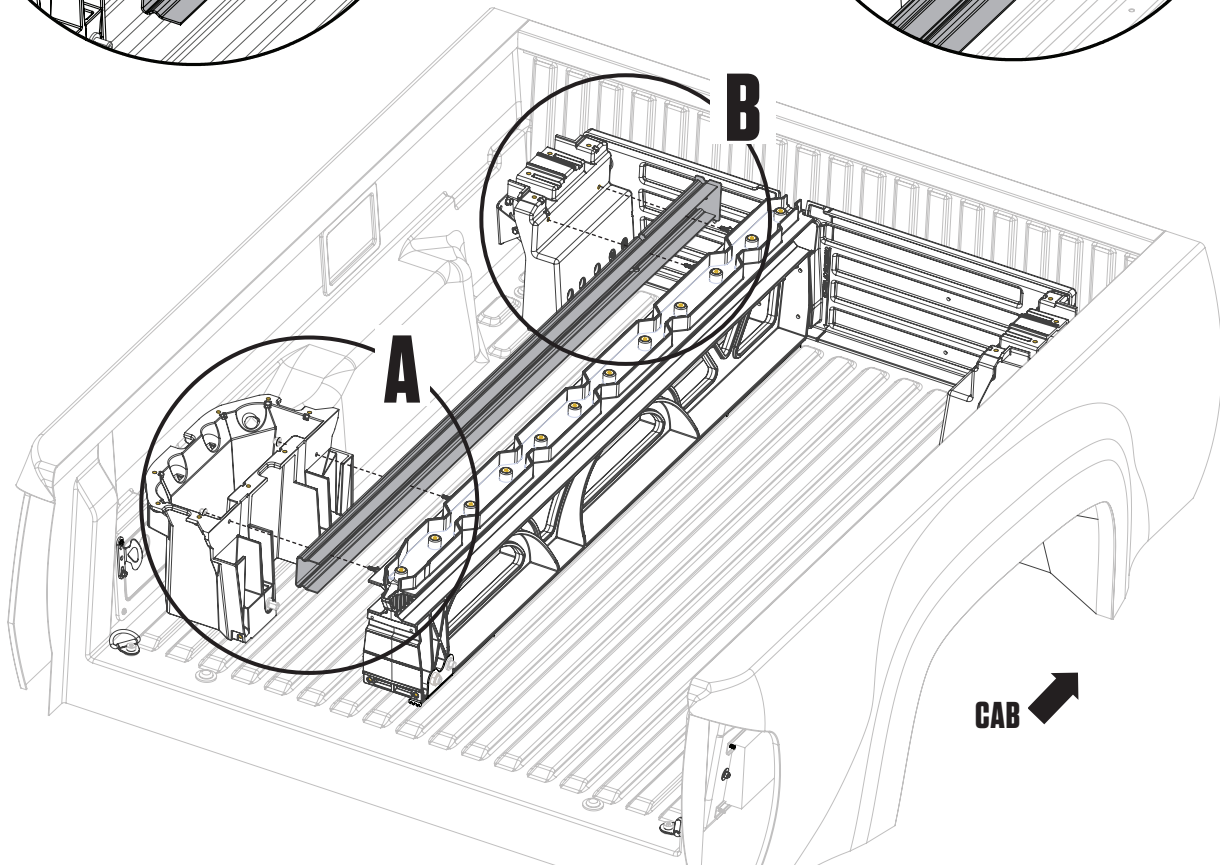
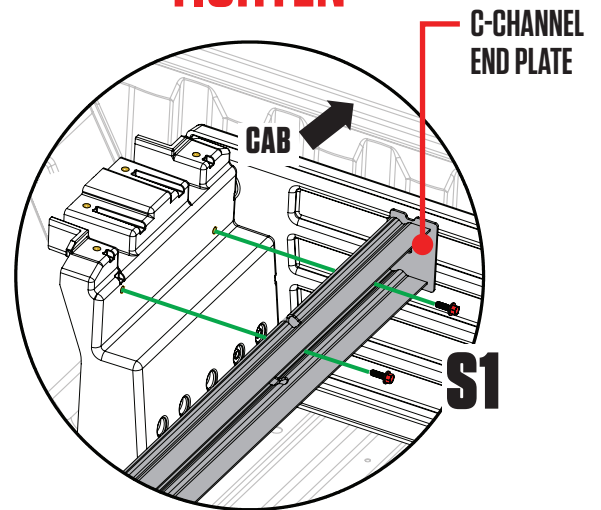



# INSTALL: DECK HALVES

- Loosely place driver side deck panel on driver side stud, center vert and ammo can.
- Shift tailgate ammo can forward, rearward, L-R, as necessary to align with fully seated deck panel.
- Loosely assemble:
  - Six bolts (without washers) through deck panel into center vert; **BAG S1**.
  - Four bolts with nylon and rubber washers installed in order shown in **DETAIL A** through deck panel into stud; **BAG S1, BAG MS WASHERS**.
  - Eight bolts with nylon and rubber washers installed in order shown in **DETAIL A** through deck panel into tailgate ammo can; **BAG S1, BAG MS WASHERS**.
  - Tighten all **S1** bolts.
  - **Securely tighten driver side C-Channel/ammo can nut and bolt.**
- Repeat passenger side (**make sure you don't forget to securely tighten passenger side C-Channel/ammo can nut and bolt**).

**RECOMMENDED TORQUE:**  
Bolts in labeled bag S1 - 27 in-lb.

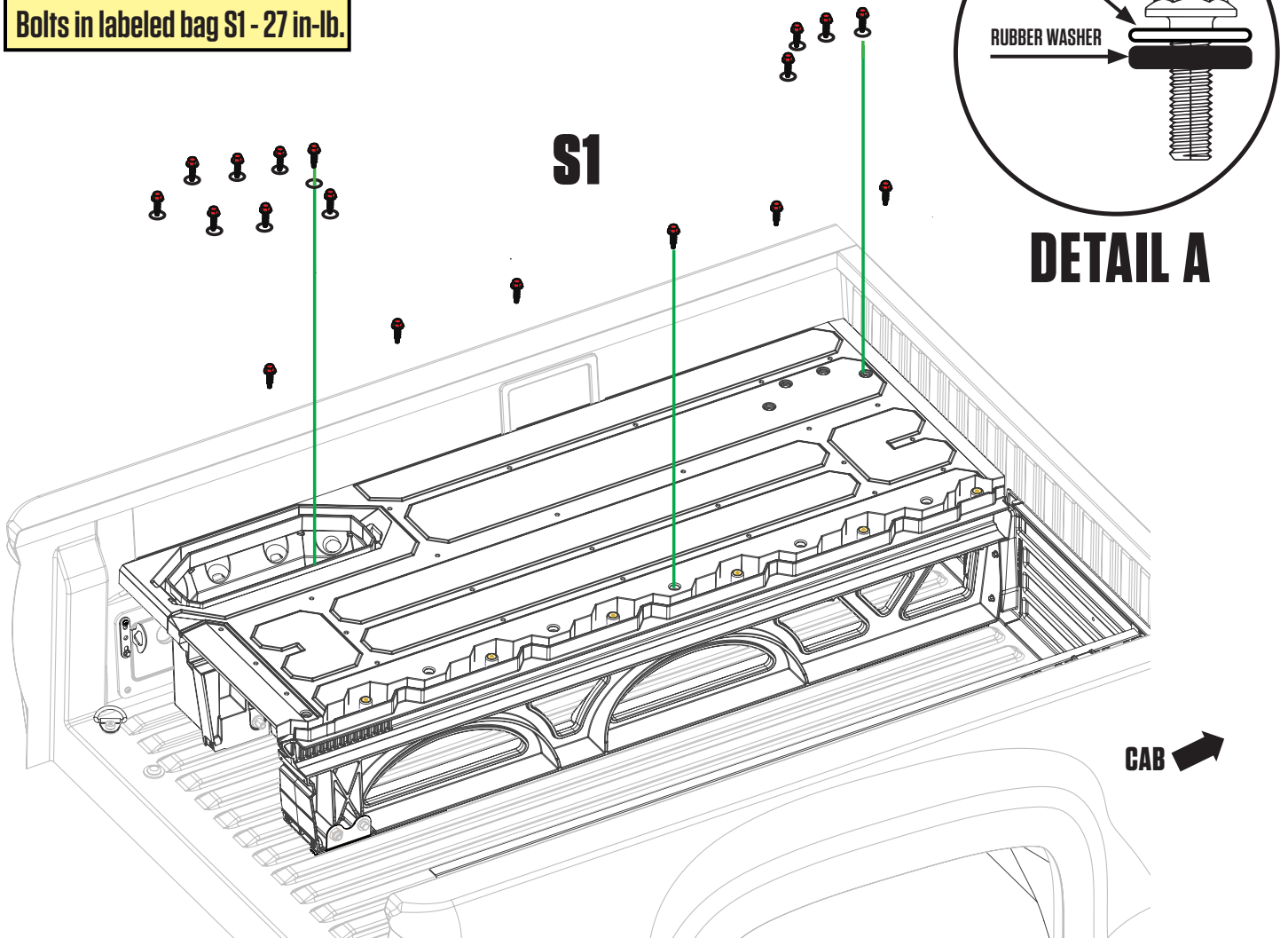



# INSTALL: J-HOOKS

- **Loosely** assemble driver side J-hook assembly in order shown through tailgate side hole in ammo can; **BAG J5**.
- Repeat passenger side.

**DRIVER SIDE AMMO CAN**  
**KEEP LOOSE**

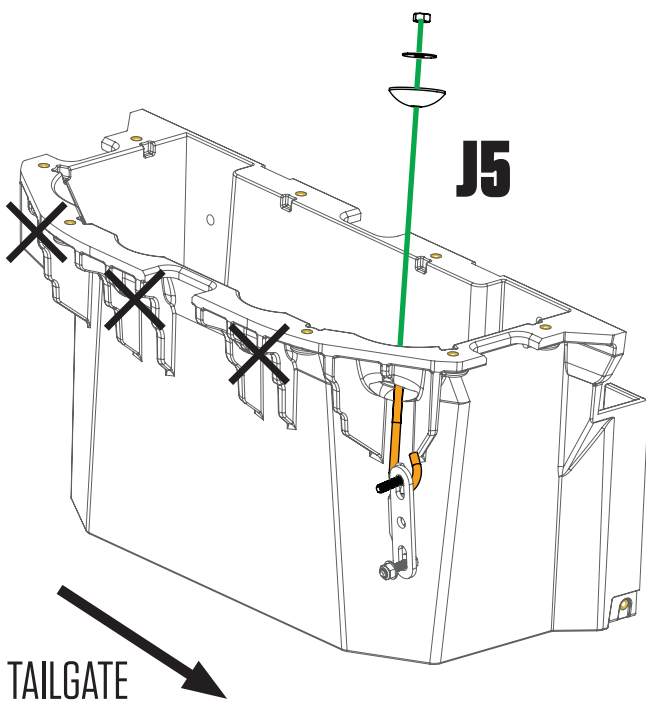

**PASSENGER SIDE AMMO CAN**  
**KEEP LOOSE**

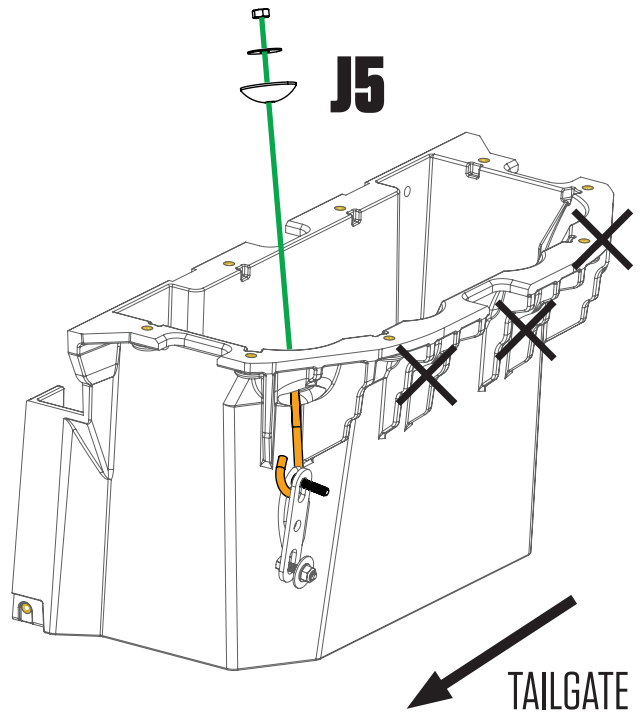

**HELPFUL TIP:** Make sure the hooks  
open toward tailgate.

# DRAWERS: BRACKETS + WHEELS

- Each drawer has a left and a right bracket. Bolt brackets into place via bottom two holes in bracket with 3/4" length bolts. Use the 2" length bolt for the upper cabside wall hole in bracket; **BAG DRAWER 1.**
- Install a tube brace in each drawer with two 3/4" length bolts; **BAG DRAWER 1, BAG DRAWER 2.**
- Attach wheels onto drawer brackets with a 7/32" hex wrench; **BAG WHEELS.**

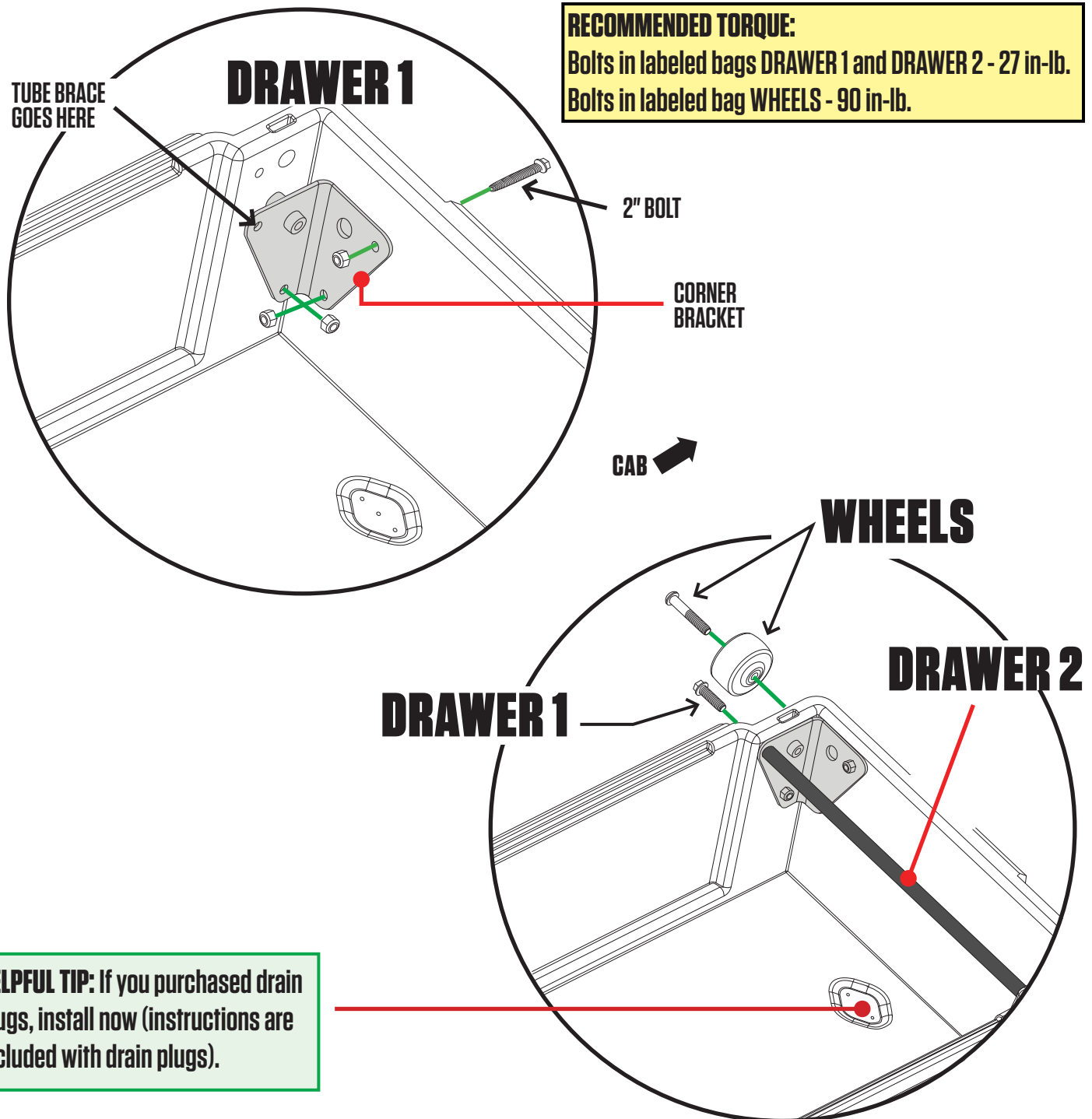

# DRAWERS: AXLE WHEELS + WEATHERSTRIPS

- Slide narrow drawer into driver side drawer cavity. **NOTE: It is easier to fully install narrow drawer first.**
- **DETAIL A:** Install two tailgate wheels onto narrow drawer axles with a 7/32" hex wrench; **BAG WHEELS.**
- Repeat with wide drawer.
- **DETAIL B:** Install weatherstrips on top of drawer edges **WITH WIPER BLADE POINTING TOWARD DRIVER.**  
**IMPORTANT: Facing the weatherstrip the wrong way will funnel water into drawer: DUH!**

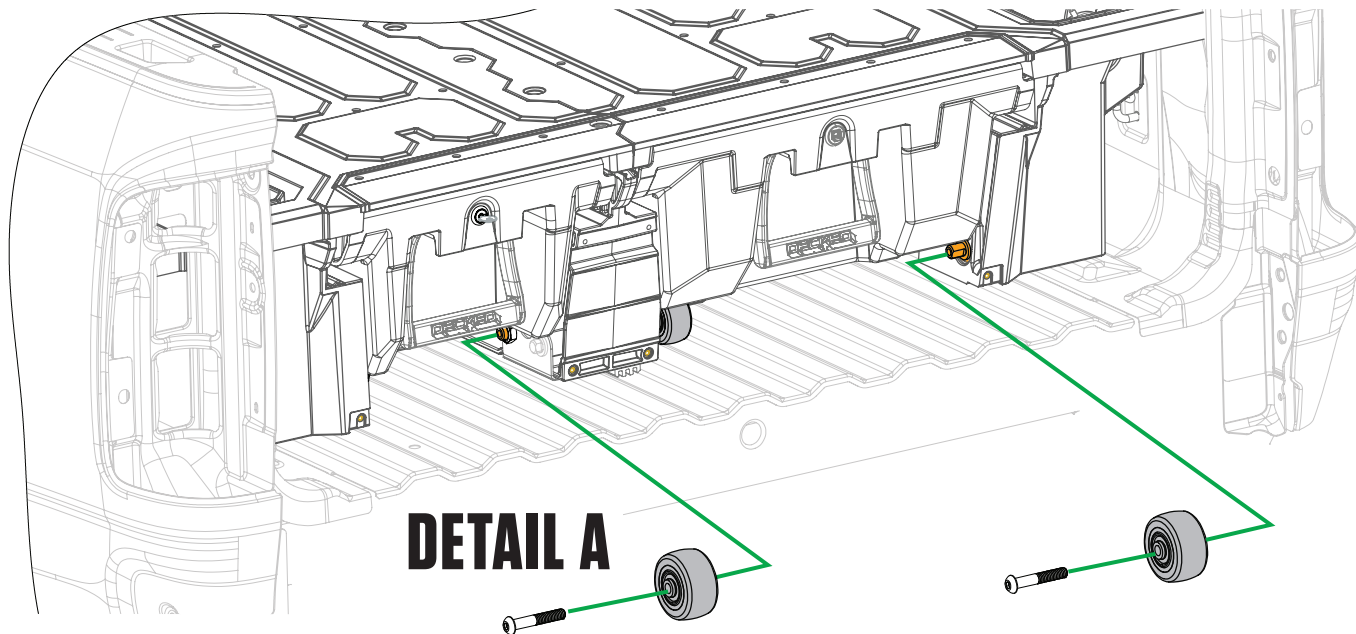

**RECOMMENDED TORQUE:**  
Wheel bolts - 90 in-lb.

**HELPFUL TIP:** To make this step easier, jam a 2" piece of material under drawer, or get your pal to pinch the drawer up to the deck to give you better leverage.

**HELPFUL TIP:** Cut weatherstrips if they overhang.

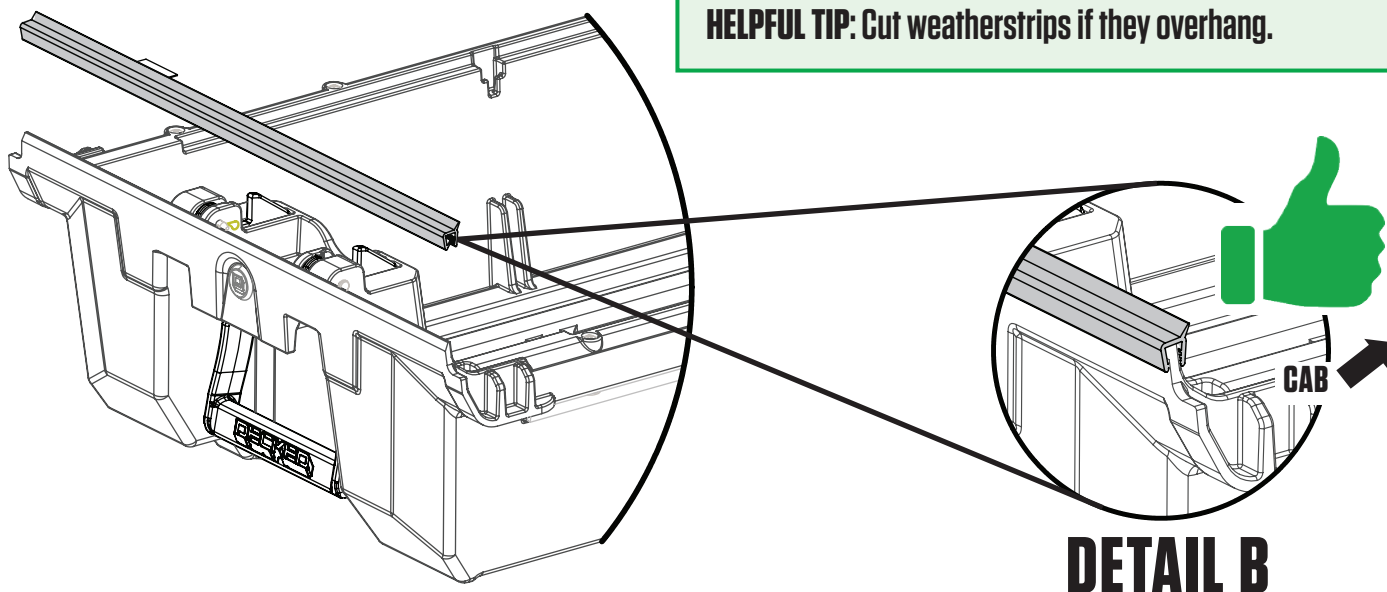

# FINAL STEPS: TORSION BRACE + BOTTLE OPENER

- Slide torsion brace under center vert and tailgate ammo cans.

**NOTE: If you jumped the gun and tightened the J-hooks when installing, loosen them.**

- Loosely install:

- Two bolts with nylon washers through the end holes in torsion brace into ammo cans; **BAG S1.**
- Two bolts with nylon washers through the bottom bottle opener holes and torsion brace into center vert; **BAG S1.**
- Two 1/2" length bolts through upper holes in bottle opener into center vert; **BAG FINAL MID.**

- Align bottle opener to edges of center vert and tighten four bottle opener bolts.

- Tighten end bolts into tailgate ammo cans.

- **Finally.....Tighten the J-hooks! DO NOT OVER TIGHTEN, just make snug. Make sure the gap between the sidewall of the bed and the deck is equal on both sides.**

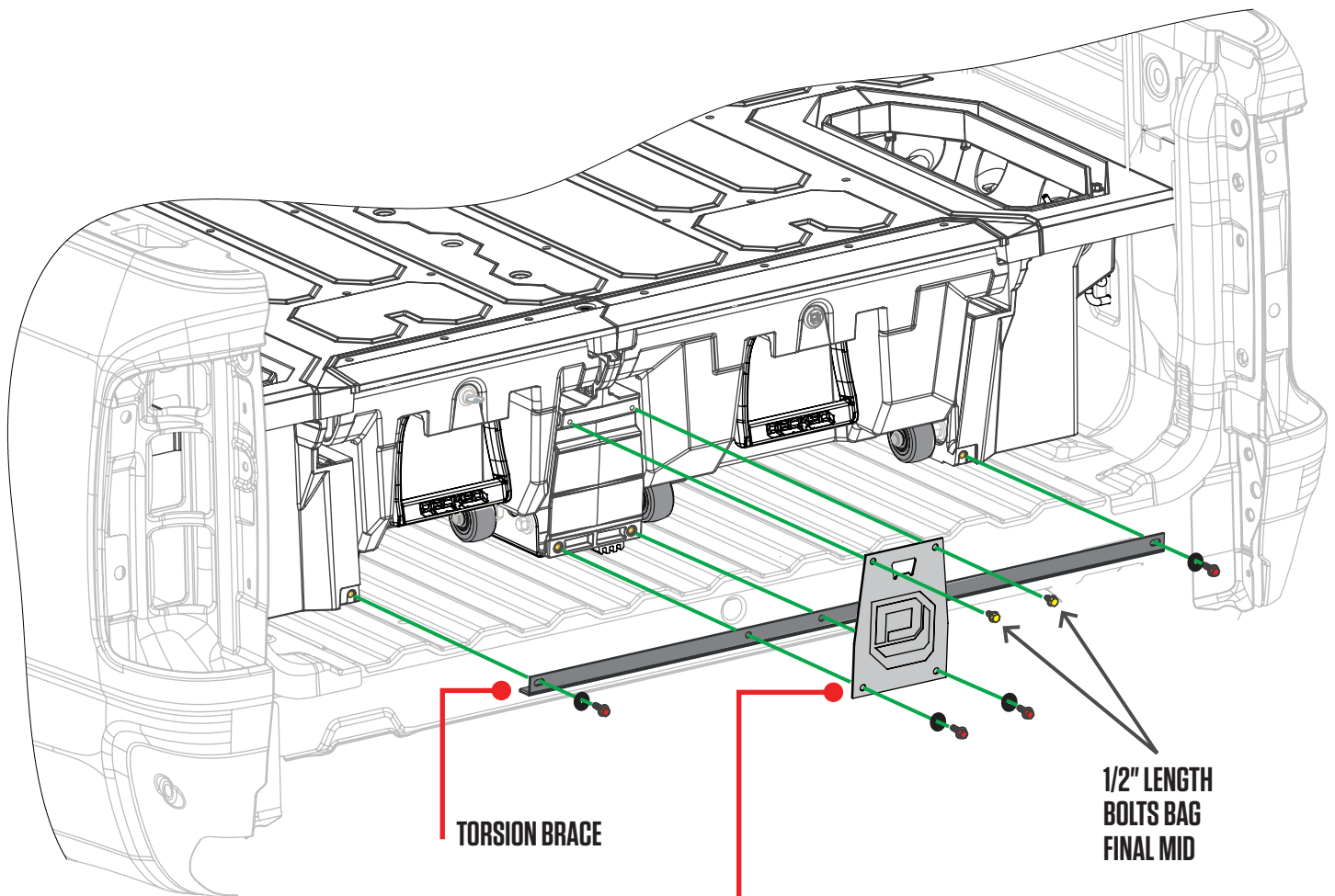

**HELPFUL TIP:** Bottle opener goes outside of torsion brace.

BOTTLE OPENER

## RECOMMENDED TORQUE:

.905" Bolts - 27 in-lb. | J-hooks - 9 in-lb.  
1/2" Bolts & 1/4" Ruler screw - 18 in-lb.

# BAM BAM: THE RULER

- Center ruler in embossed area and screw three 1/2" length Phillips screws through the tailgate side holes directly into deck panels; **BAG FINAL MID.**  
**NOTE: These are small gauge screws. Tighten to a light snuggle ONLY.**
- For the three cabside ruler mounting holes, drill each with a 9/64" bit and a drill stop set to 1/2". There is a lateral steel tube that runs on the underside of the deck at this location. (SEE UNDERSIDE VIEW OF DECK).  
**IMPORTANT: Only drill through TOP of steel tube; do not drill through bottom of tube, 'lest you want to pull a Niagara Falls and funnel water into your drawers.**
- Screw three 3/4" length Phillips screws into the cabside ruler holes you just drilled; **BAG FINAL MID.**

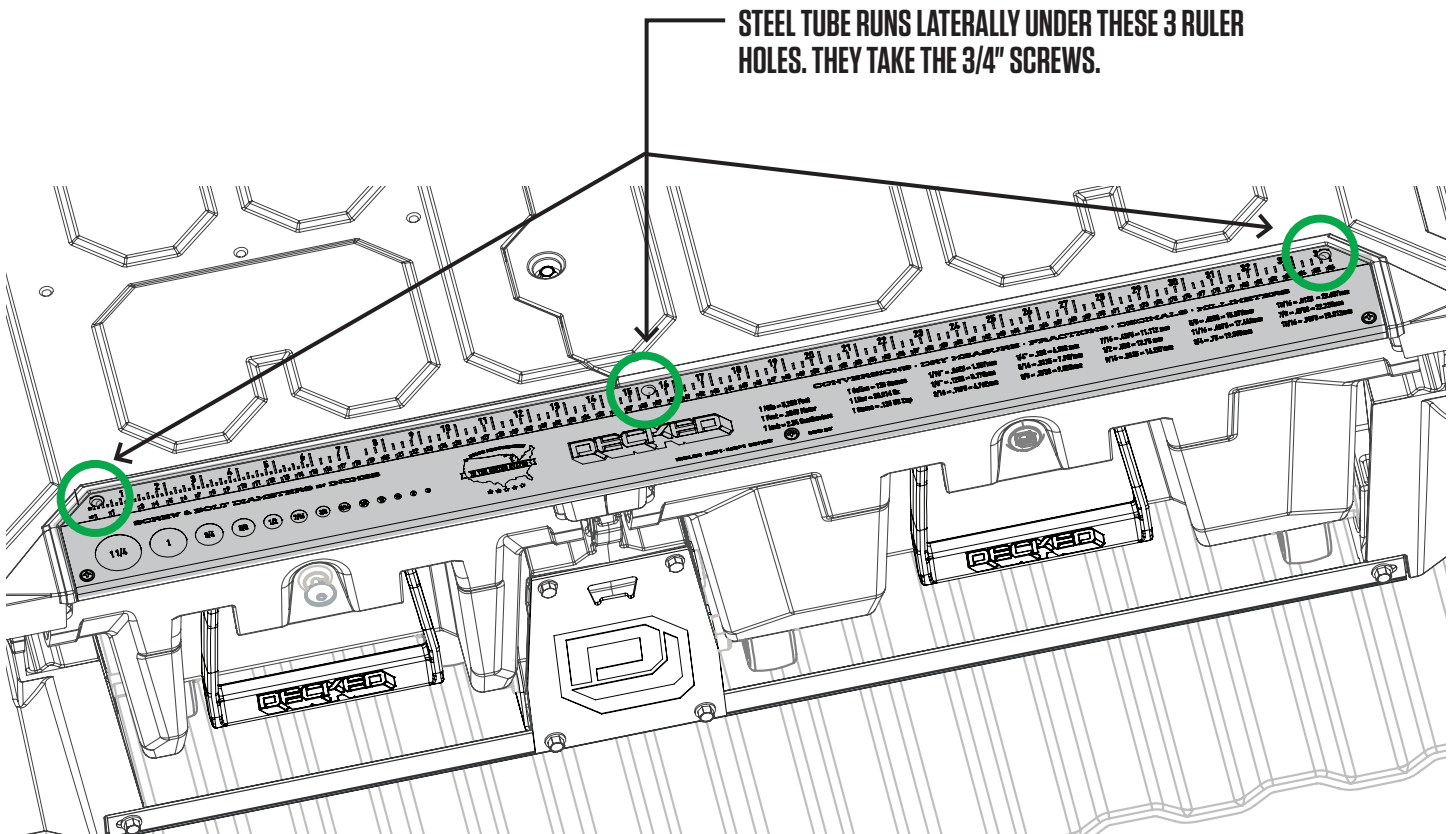

## UNDERSIDE VIEW OF DECK

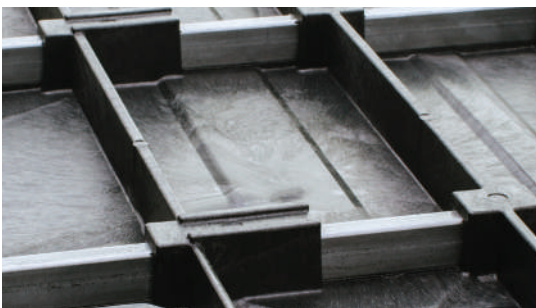

**DO:** Drill through the top of steel tube ONLY.

**DO NOT:** Drill through both sides of steel tube = **YOU'RE FIRED!**





# FINAL STEPS: AMMO CAN LIDS

- **DETAIL A:** Ammo can lids are driver (marked L) and passenger (marked R) side specific.
- **DETAIL B:** Holding lid in orientation shown, insert tab on tailgate end of ammo can lid and push the cabside end of lid down to secure. Don't be afraid to give'r the Fonzi to close, it's rugged.
- Insert lock hole plugs, unless you ordered drawer locks! Install drawer locks now (instructions with locks); **BAG FINAL MID.**

**IMPORTANT:** Grab your favorite beverage, crack 'er open in the bottle opener and christen this ship! You did it. Immediately post a photo of your significant other, child or canine (in no order of significance) appreciating your accomplishment.

## DETAIL A

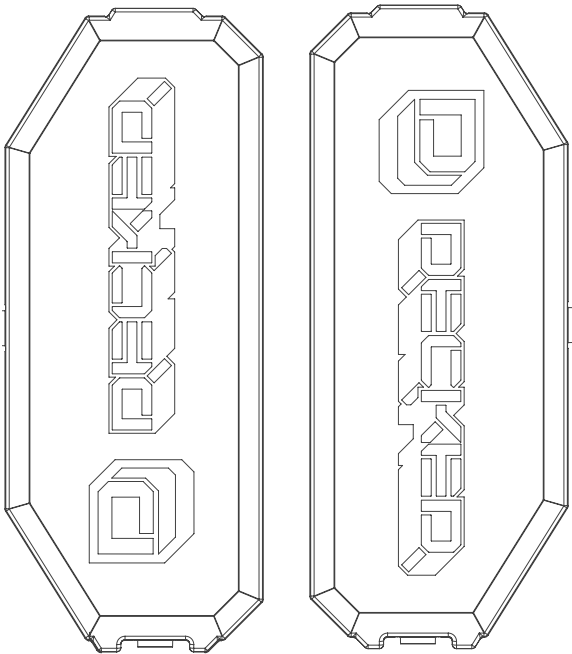

DRIVER SIDE  
AMMO CAN LID

PASSENGER SIDE  
AMMO CAN LID

## DETAIL B

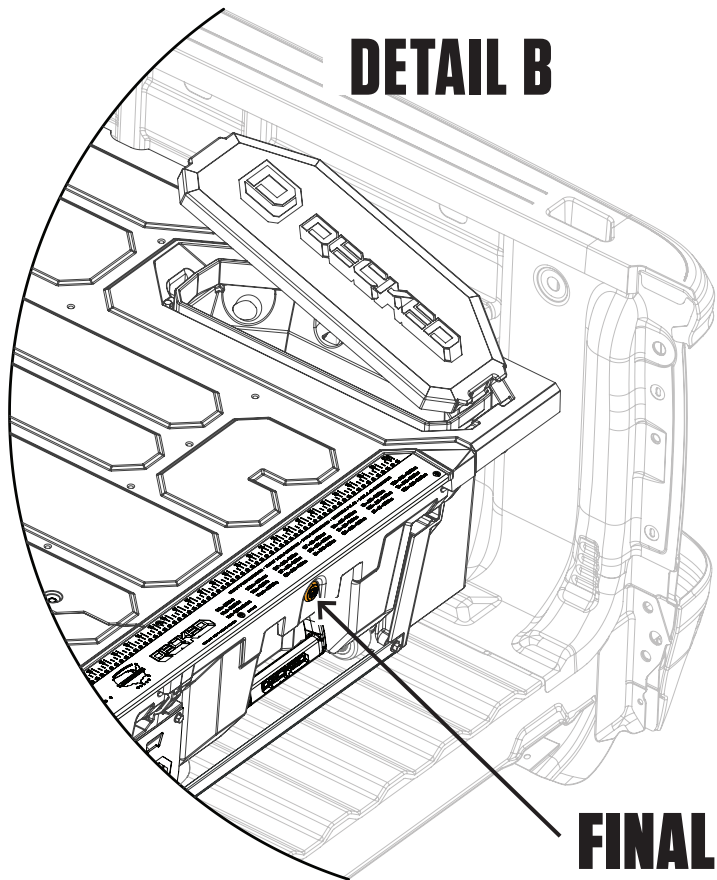

**FINAL MID**

When it comes to quality truck bed accessories, [DECKED](#) is the brand you can depend on.