



Installation Instructions: MG3 - MG4

CHEVY COLORADO/GMC CANYON 5'2" or 6'4" BED LENGTH

NOTE: Most of the images in these instructions are of the short bed, but they apply to both length beds

2015-CURRENT

TOOLS REQUIRED

- Adjustable wrench (that opens to about 1")
- 1/2" open end wrench
- #2 Phillips screwdriver,
- Short 7/32" hex wrench
- 7/16" deep socket
- 3/8" socket
- Electric drill
- 9/64" drill bit
- Drill stop

▼ HEY! TORQUE BOY: READ BEFORE YOU INSTALL DECKED ▼

1. **DON'T** over tighten bolts, get em' good 'ole hand-tight.
2. **DON'T** use power tools.
3. If you don't follow directions and do use power tools:
 - 1). Set clutch at a very low setting.
 - 2). Don't blow it.
 - 3). If you blow it, see NOTE.*

NOTE* Two extra threaded inserts are included in BAG PREP-EXTRA. That's all you get.

- 4). **DON'T** over tighten J-hooks during installation. Make 'em good and snug enough to keep the system from moving in the bed.

- 5). Do read these instructions closely.

NOTE: Most of the images in these instructions depict the short CHEVY/GMC bed, but they apply to both length beds.

▼ ASSEMBLY OVERVIEW ▼

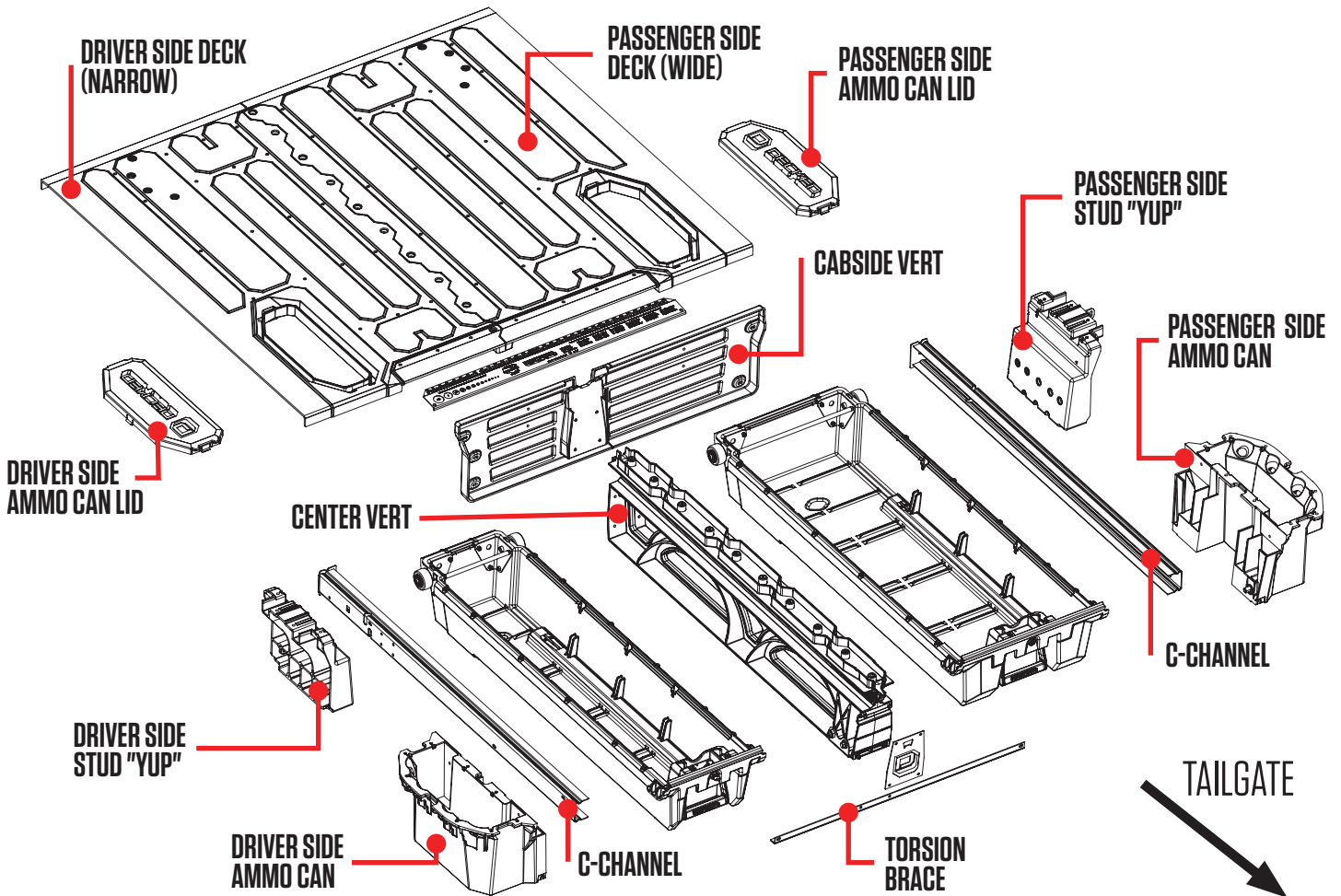

PREP BED: MARK CENTER OF BED

- Use a marking pen or wax pencil to mark a centerline (blue) on the raised center bead.

DETAIL A

MAKE SURE MARK SITS AT LEAST
14" HIGH (SO YOU CAN SEE IT)

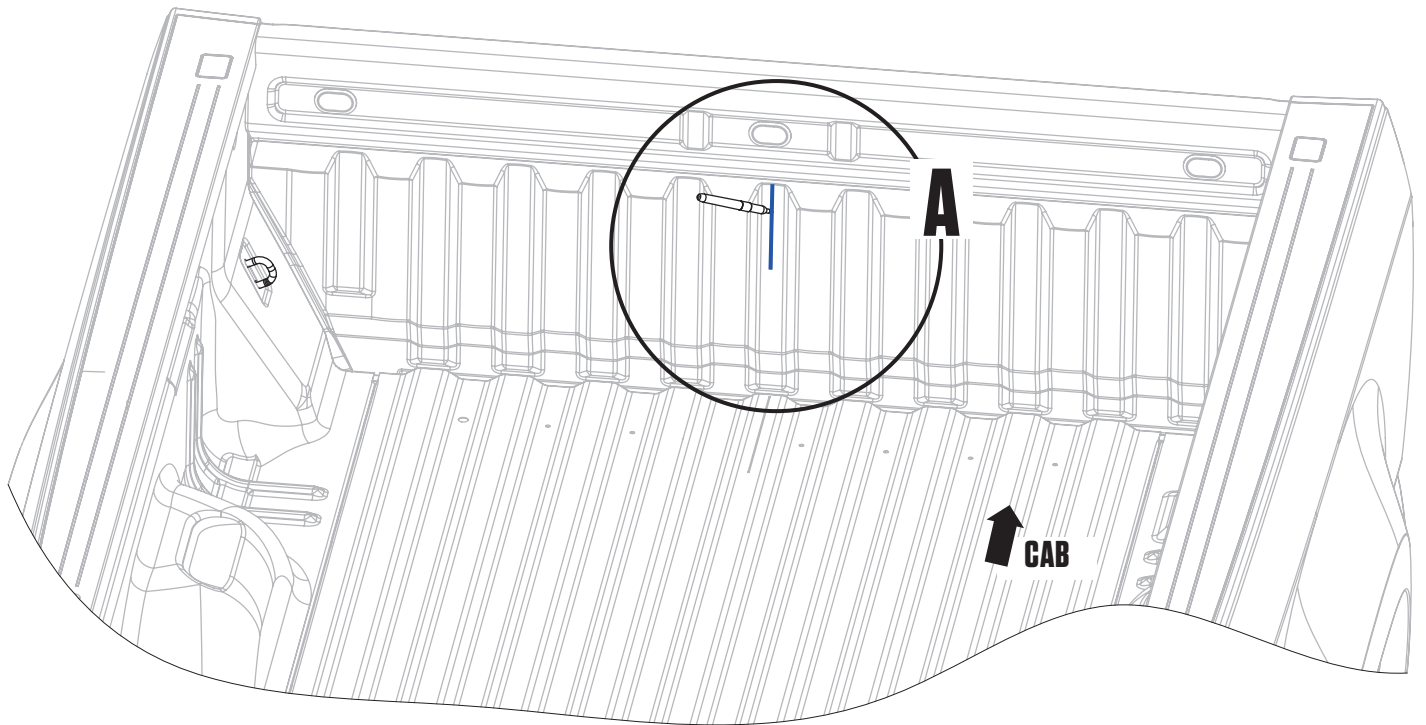
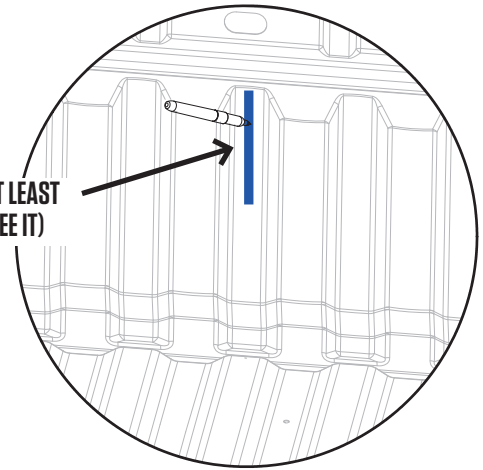

PREP BED: SHIMS

- **2 SHIMS** that look like this can be found in your hardware kit.
- Using the information below:
 - 1) Clean the bed surface where the shims will be located. Isopropyl alcohol (do not drink) is recommended.
 - 2) Remove tape film and apply shim with the strength of 1000 men a.k.a push really hard.

DETAIL B

Align shim to channel in floor shown. Place shim 7" from rear of bed (red).

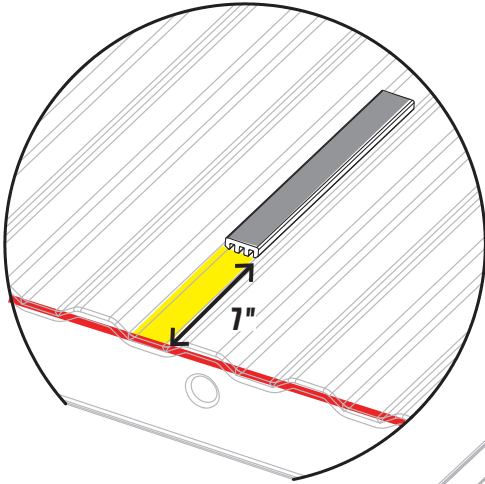

DETAIL A

Align shim to channel in floor shown 3" from cabside panel of bed (red).

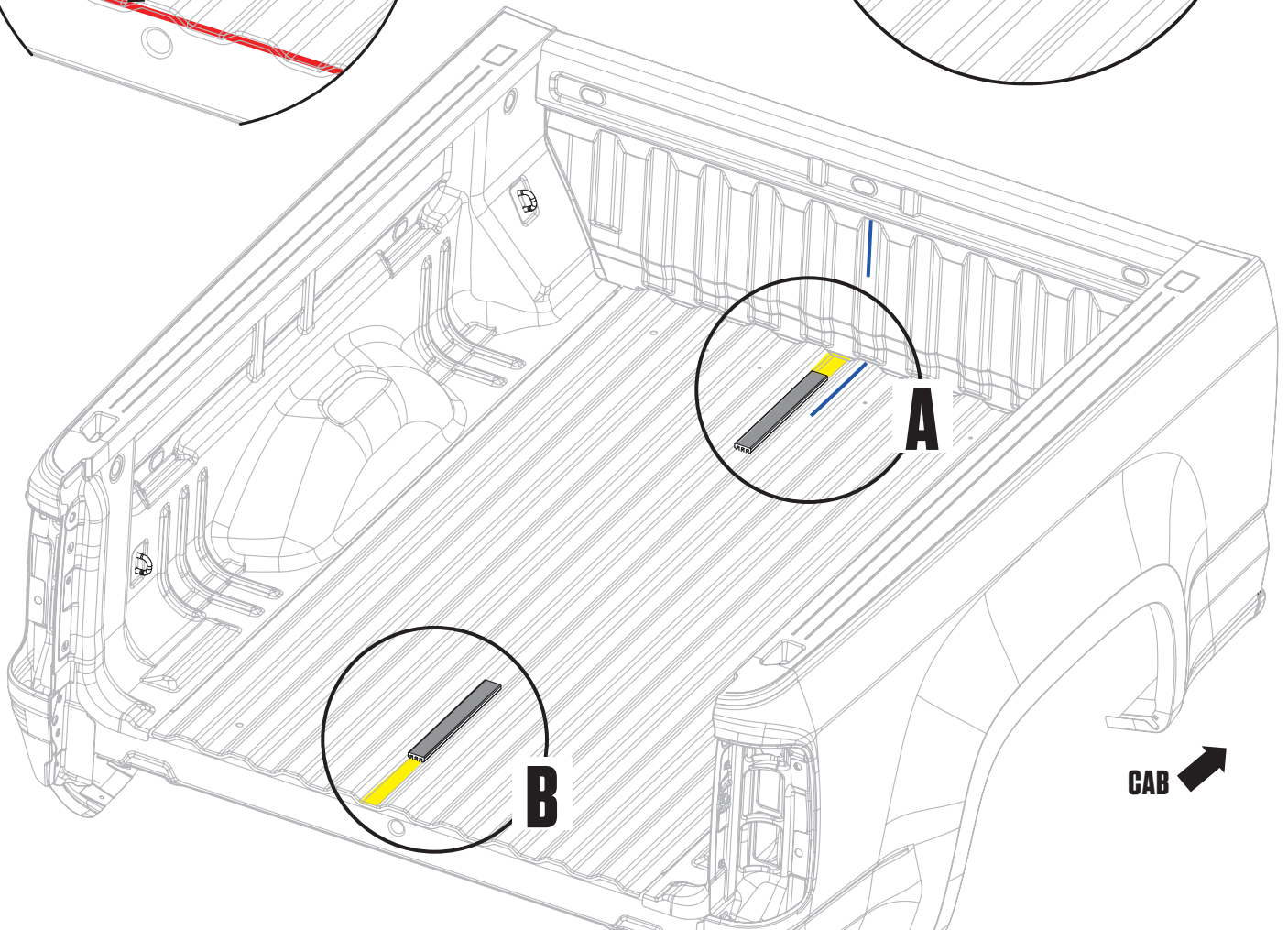
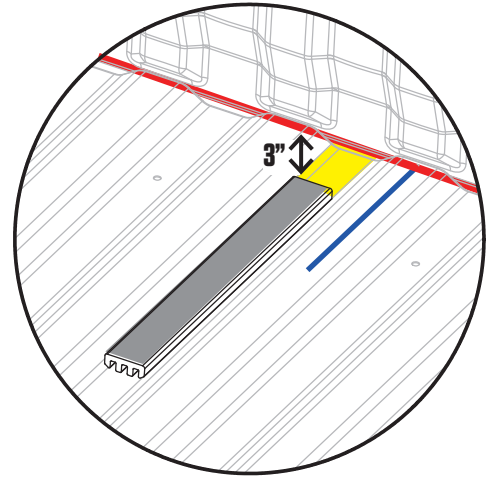

PREP BED: CABSIDE TIE-DOWNS

- Sandwich the factory driver side tie-down (green) in between the cabside tie-down bracket (yellow) and the clamp plate (red); BAG **PREP-MG34**
- Fasten securely through the circular holes with 1" bolt and flanged nut; BAG **PREP-MG34**
- Repeat passenger side.

DETAIL A

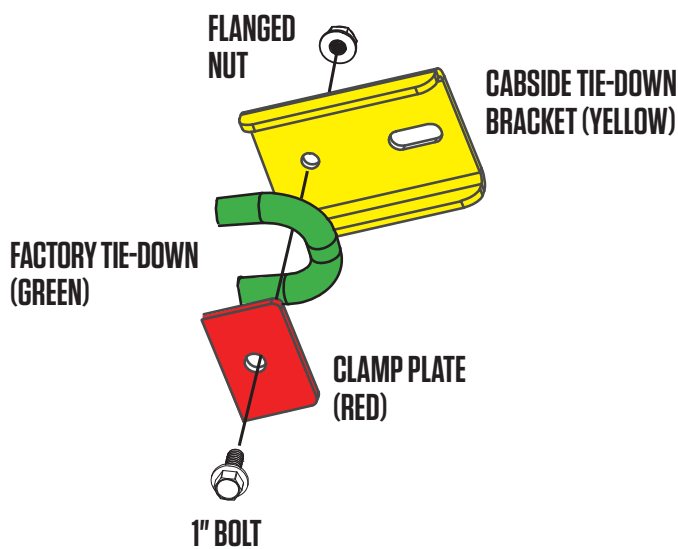

DETAIL A INSTALLED

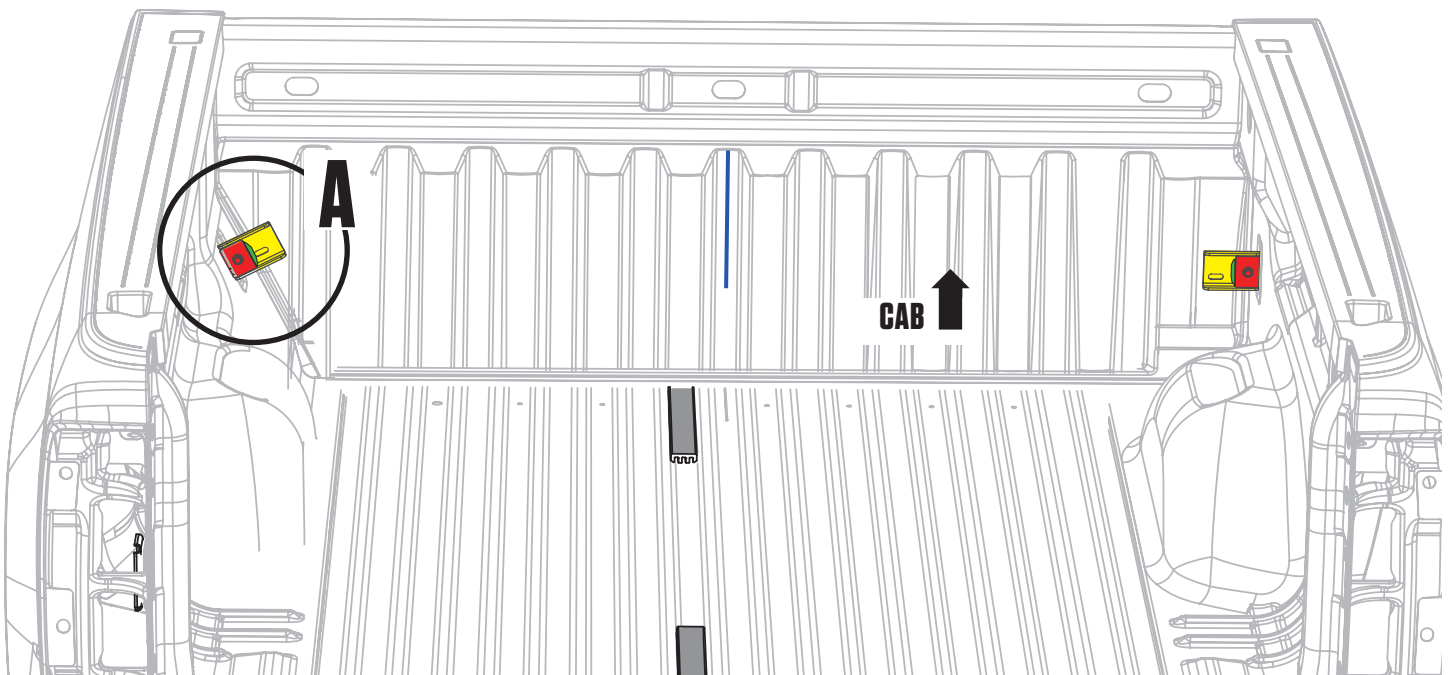
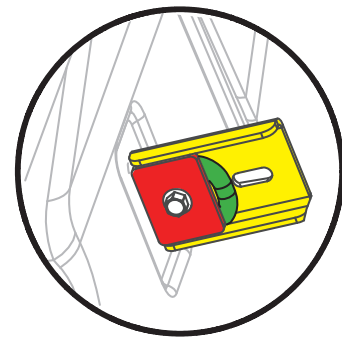

ASSEMBLY: CENTER VERT + CABSIDE VERT

NOTE: Perform the next few steps on a flat surface like a garage floor.

- Attach center vert to cabside vert with four bolts. Alternate to tighten; BAG S1.

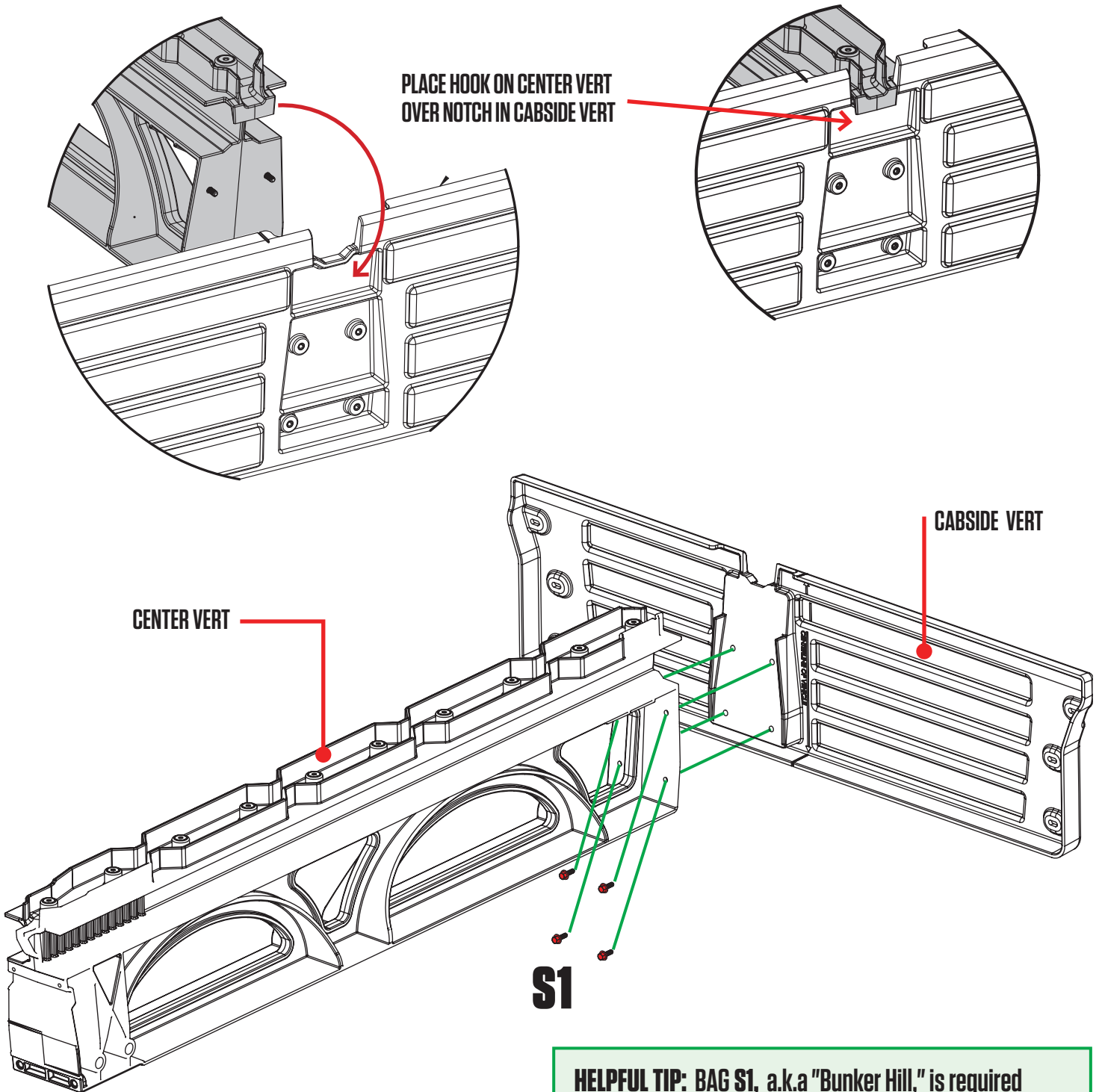

HELPFUL TIP: BAG S1, a.k.a "Bunker Hill," is required for most of the steps, so keep it close! These bolts are highlighted throughout instructions in **RED**.

ASSEMBLY: LOOSELY ATTACH STUDS (YUP)

- **LOOSELY** attach studs to cabside vert with six bolts; BAG **S1**.

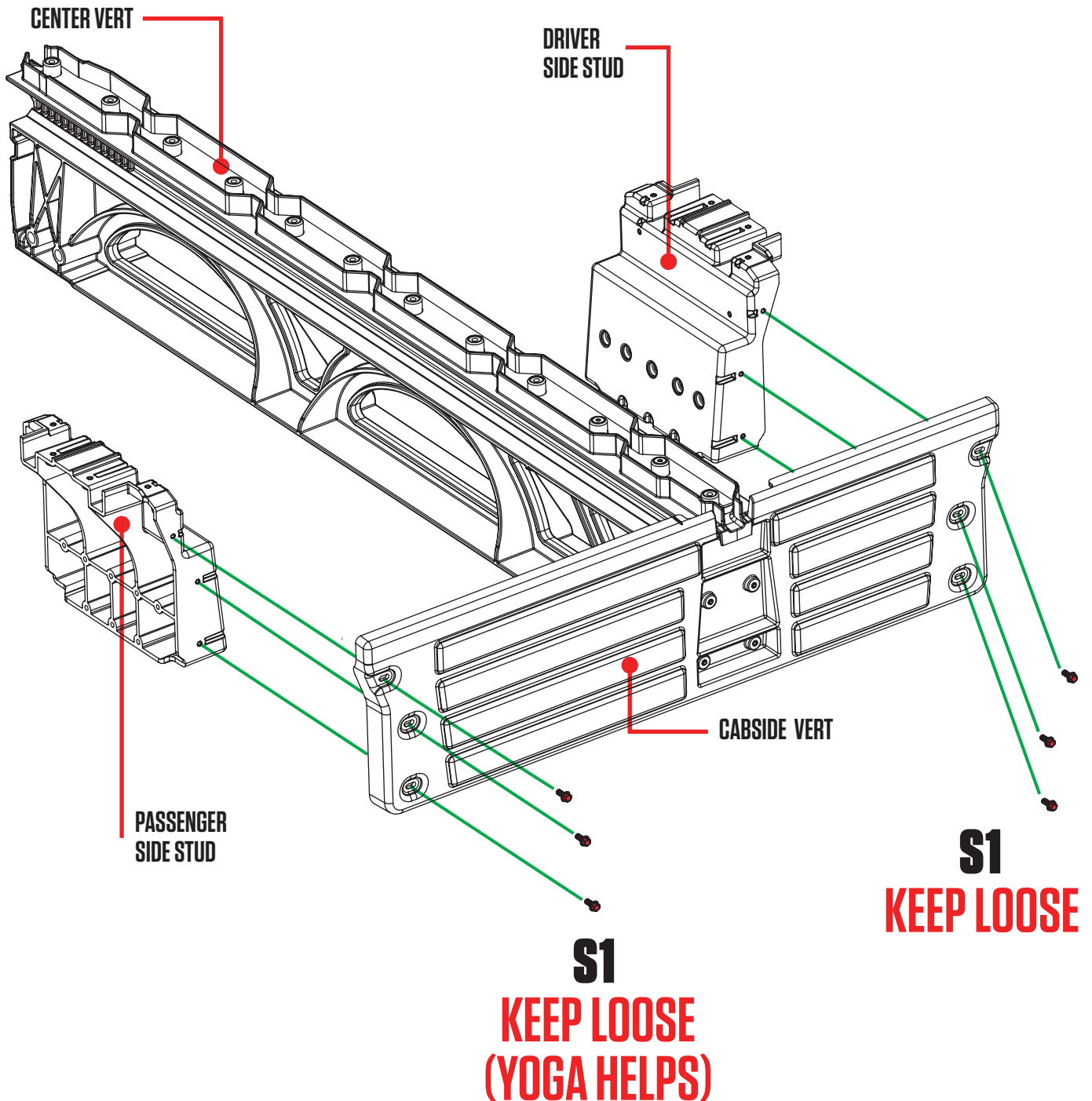

ASSEMBLY: ALIGN & TIGHTEN STUDS (YUP)

NOTE: This step ensures the studs are properly located before tightening bolts. It's important.

- Place ammo cans to support tailgate end of deck panels.
- Lift deck panels on center vert + stud + cabside vert assembly.
- Slide studs around L-R until deck panels are seated.
- **DETAIL A:** Loosely secure four bolts to hold decks onto studs; **BAG S1**.
- Now you can securely tighten the bolts that hold the studs to the cabside vert.
- Unbolt deck from studs, remove deck panels, save bolts, remove ammo cans and set aside for later assembly.

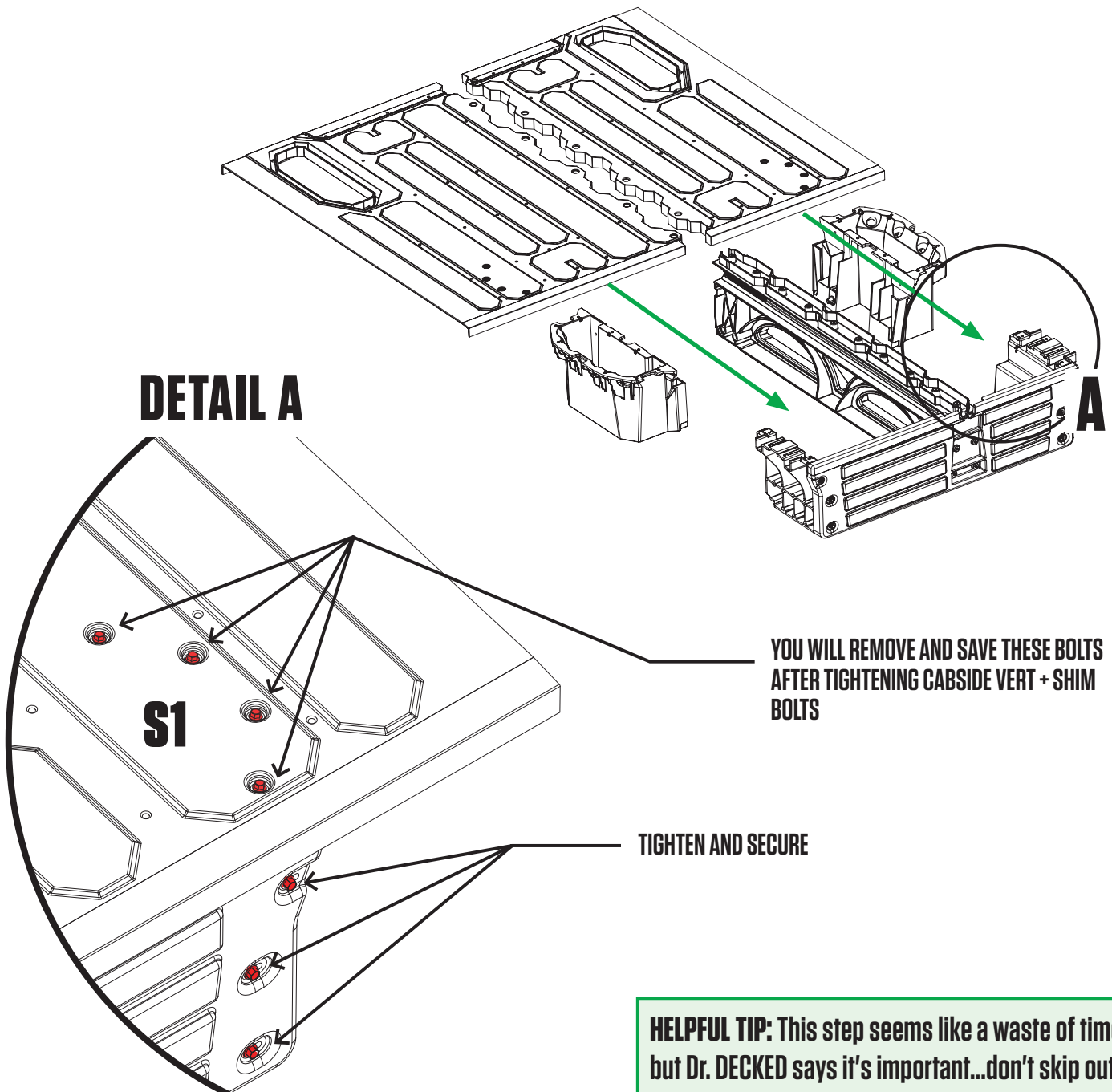

ASSEMBLY: STUD BRACKETS

- **DETAIL A:** Attach driver side stud bracket to driver side stud using three 3 1/2" bolts and three flanged nuts into proper hole locations (green). Tighten securely; BAG PREP-MG34
- **DETAIL B:** Repeat steps in DETAIL A on passenger side.

DETAIL A

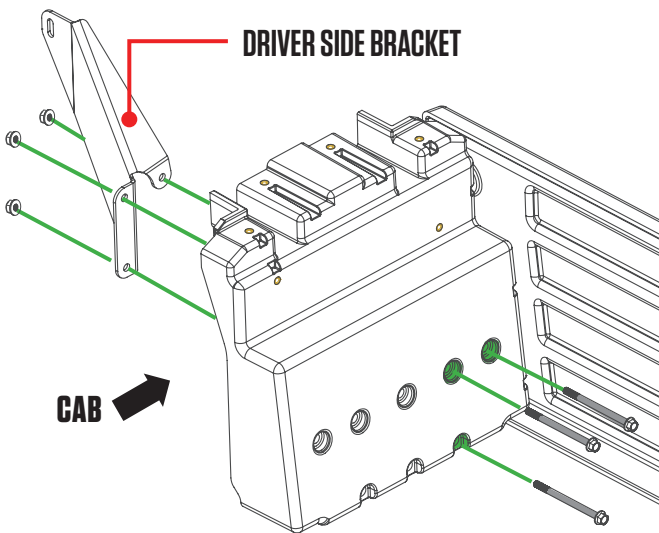

DETAIL B

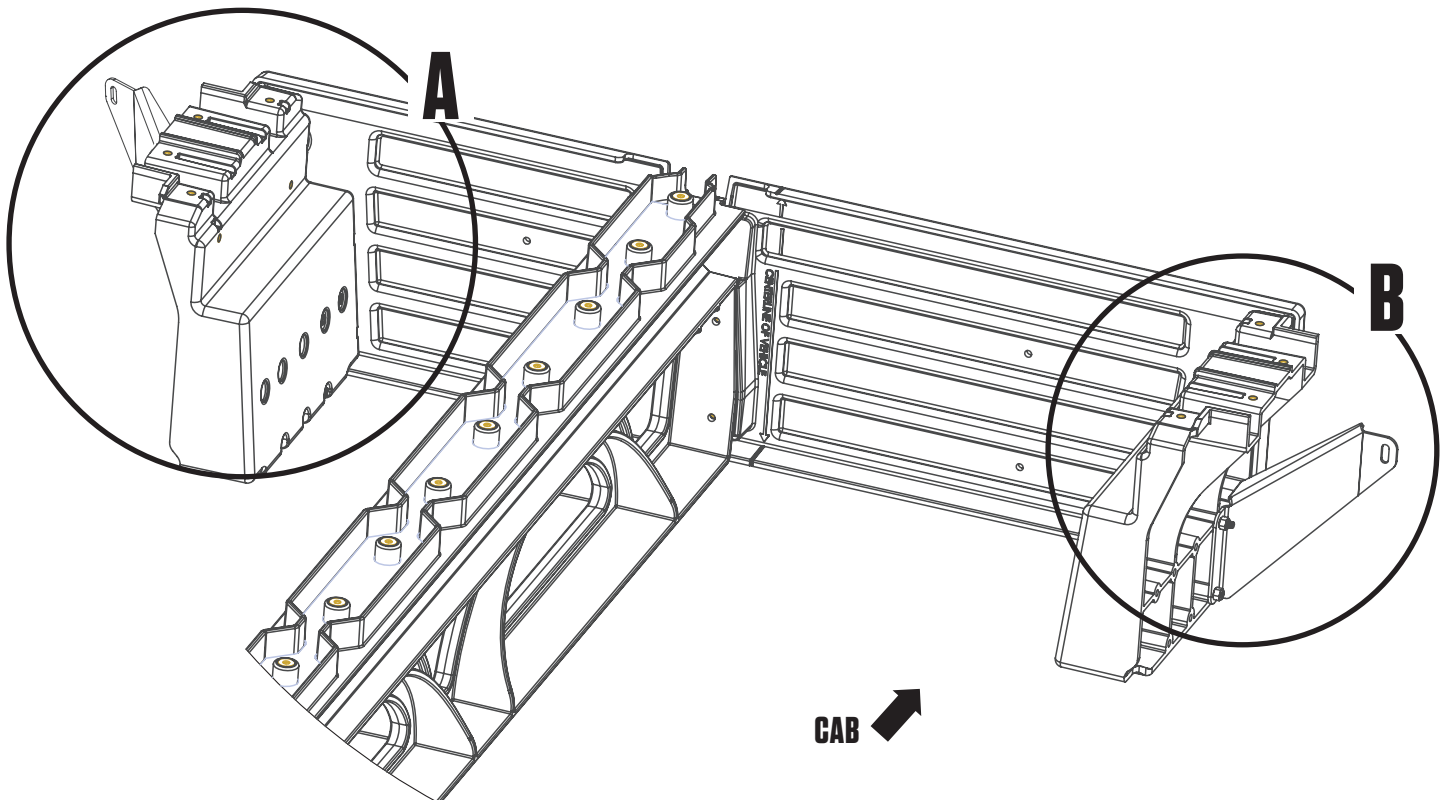
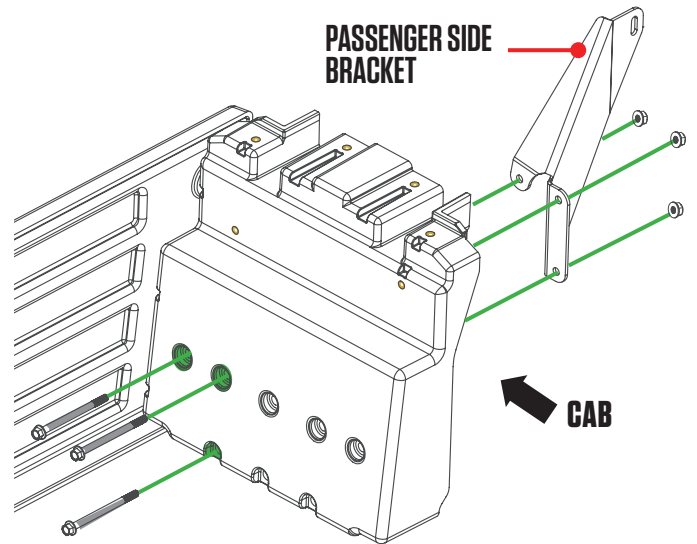

ASSEMBLY: MOUNT ASSEMBLY

- **DETAIL A:** While supporting both ends, lift center vert + stud + cabside vert assembly in truck bed.
NOTE: Make sure centerline arrows on cabside vert are aligned with your centerline marks (blue).
- **DETAIL B:** Place stud brackets cabside of cabside brackets (yellow). Loosely fasten with 3/4" bolt and flanged nut; BAG PREP-MG34.
- Repeat passenger side.
- Make sure assembly is still on centerline, then securely tighten both sides.

DETAIL A

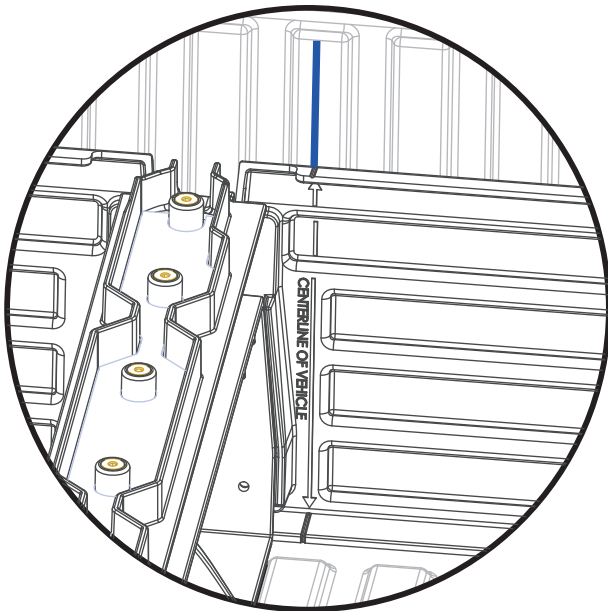

↑ CAB

DETAIL B

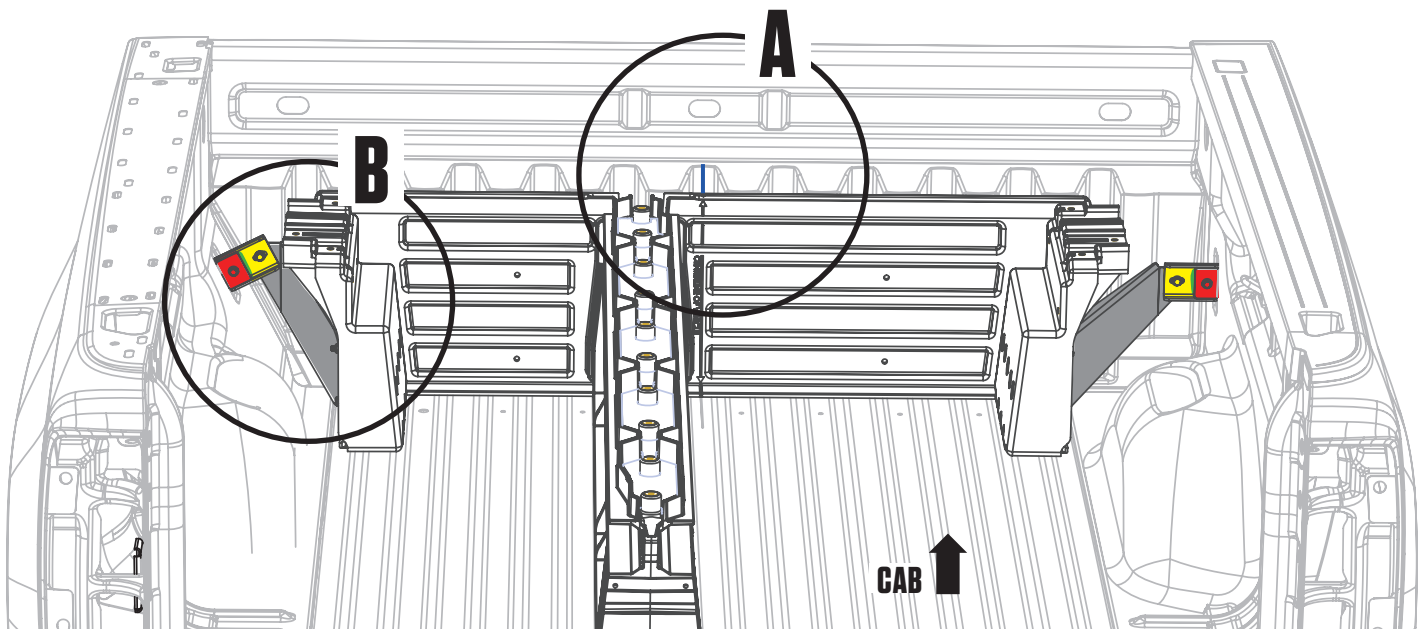
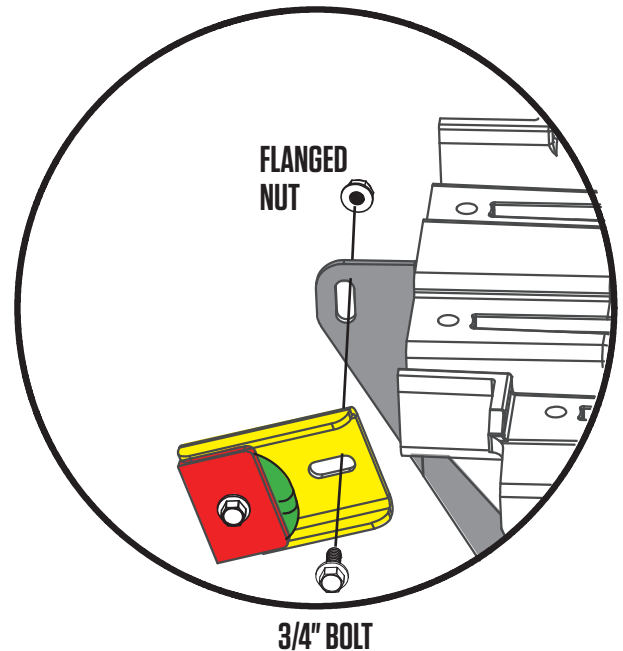

INSTALL: C-CHANNEL

- Loosely place driver side ammo can at tailgate corner of bed.
- Place driver side C-channel on ledge of stud and ammo can with end plate cabside.
- **DETAIL A:** Insert two bolts through C-channel into ammo can and loosely fasten with nut; BAG **S2**, BAG **N1**.
- **DETAIL B:** Tightly attach C-channel to stud; BAG **S1**.
- Repeat passenger side.

DETAIL A KEEP LOOSE

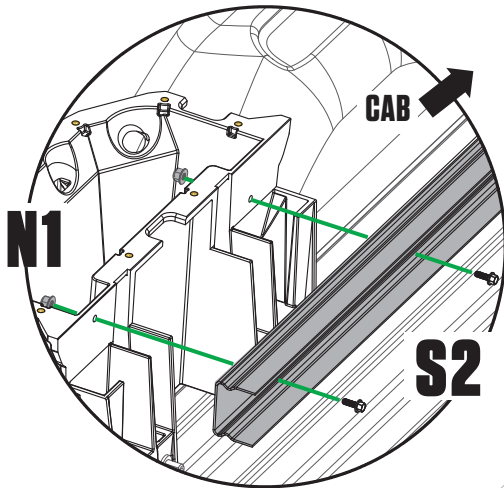

DETAIL B TIGHTEN

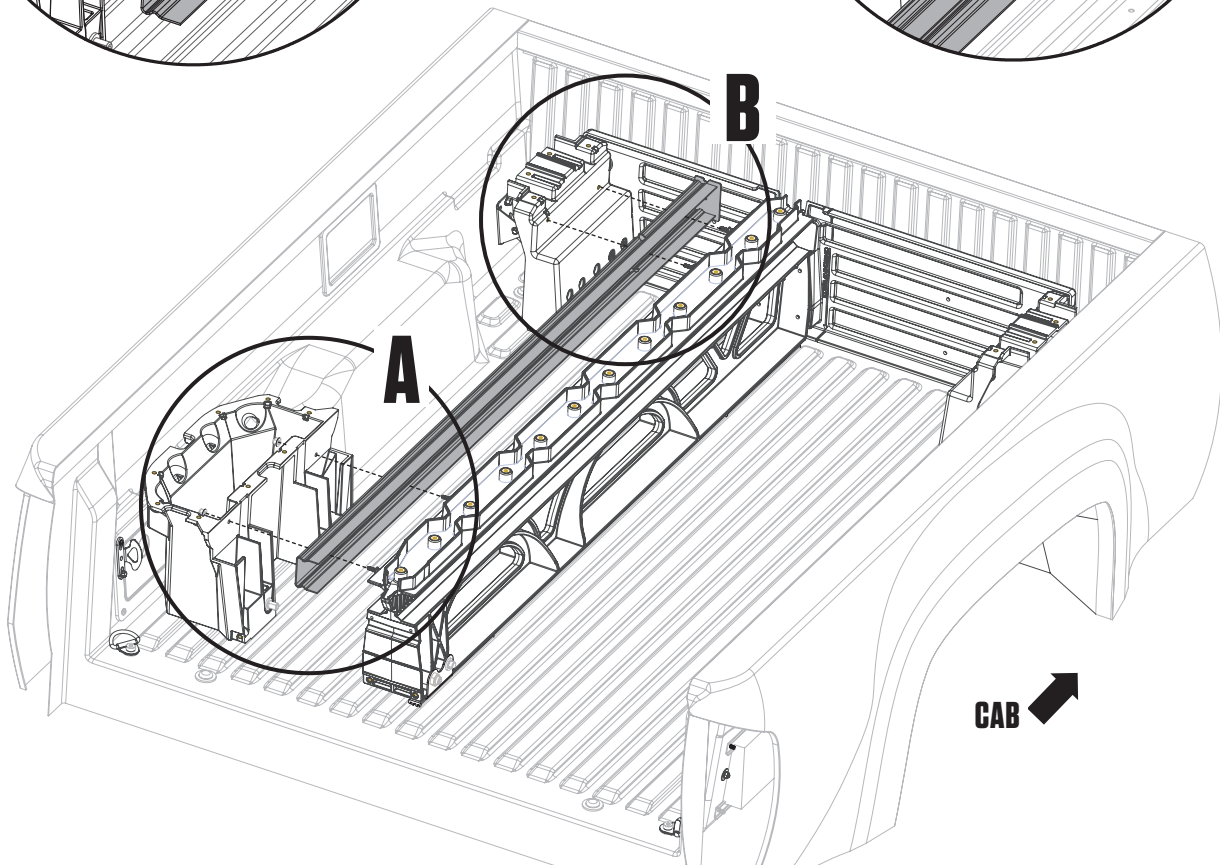
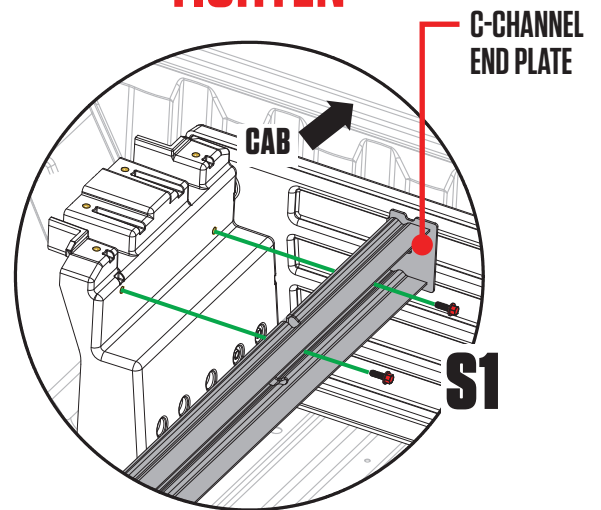

INSTALL: DECK HALVES

- Loosely place driver side deck panel on driver side stud, center vert and ammo can.
- Shift ammo can forward, rearward, L-R, as necessary to align with fully seated deck panel.
- Loosely assemble:
 - Five (5'2" bed) or six (6'4" bed) bolts through deck panel into center vert; BAG **S1**.
 - Four bolts with O-rings through deck panel into stud; BAG **S1**, BAG **O-RINGS**.
 - Eight bolts with O-rings through deck panel into ammo can; BAG **S1**, BAG **O-RINGS**.
 - Tighten all S1 bolts.
 - **Securely tighten driver side C-Channel/ammo can nut and bolt.**
- Repeat passenger side (make sure you don't forget to securely tighten passenger side C-Channel/ammo can nut and bolt).

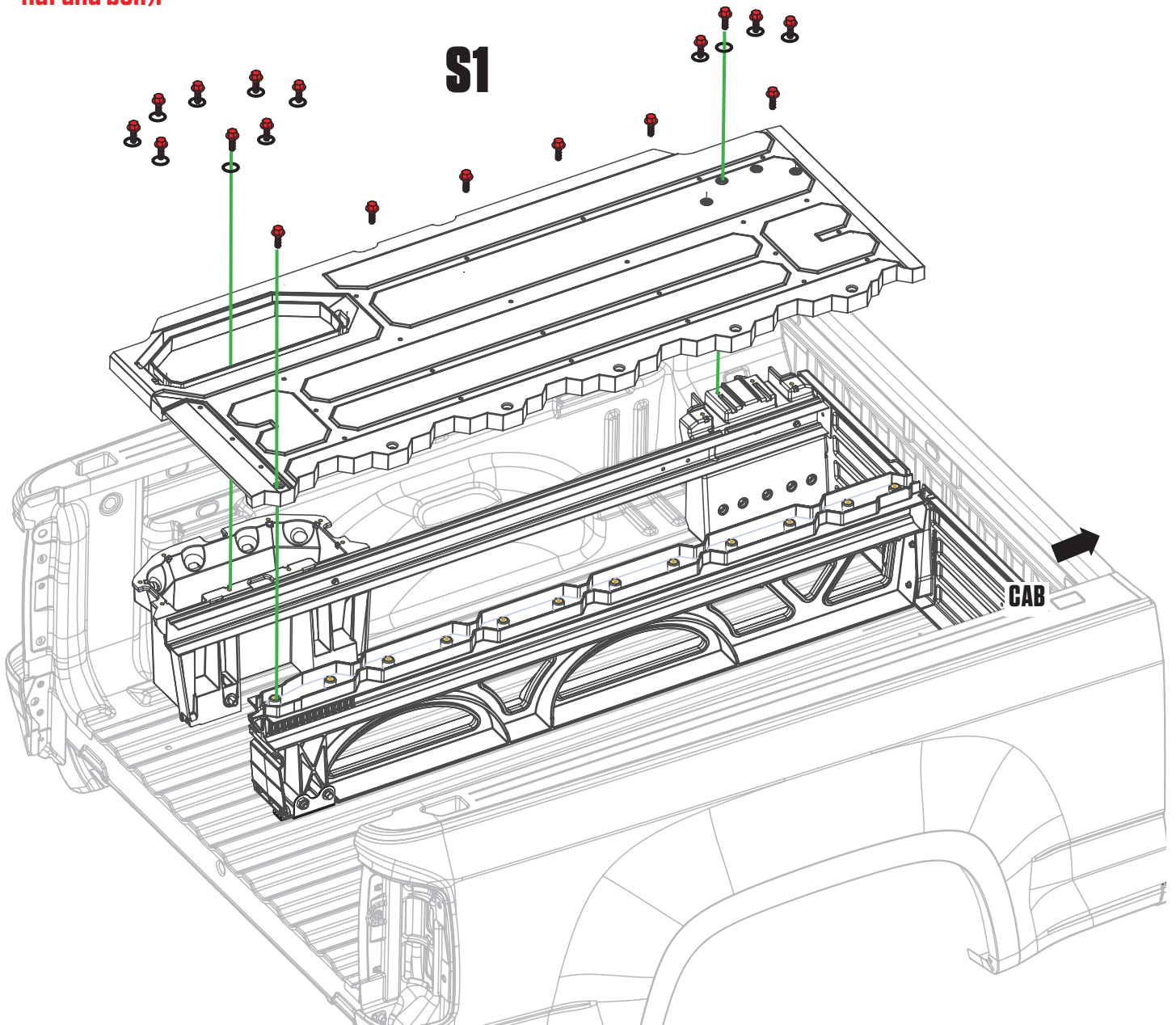

INSTALL: J-HOOKS

- **Loosely** assemble driver side J-hook assembly in order shown through second closest tailgate side hole in ammo can as shown; **BAG J5**.
- Repeat passenger side.

DRIVER SIDE AMMO CAN
KEEP LOOSE

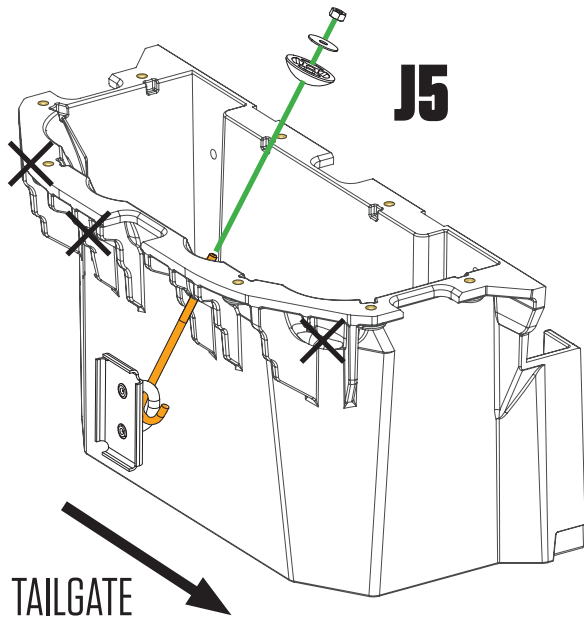

PASSENGER SIDE AMMO CAN
KEEP LOOSE

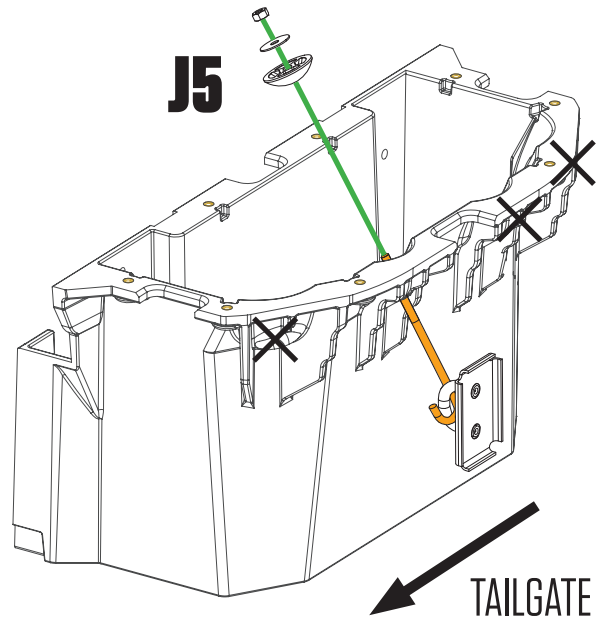

HELPFUL TIP: Make sure the hooks
open toward tailgate.

DRAWERS: BRACKETS + WHEELS

- Each drawer has a left and a right bracket. Bolt brackets into place via bottom two holes in bracket with 3/4" length bolts. Use the 2" length bolt for the upper cabside wall hole in bracket; BAG **DRAWER 1**.
- Install a tube brace in each drawer with two 3/4" length bolts; BAG **DRAWER 1**, BAG **DRAWER 2**.
- Attach wheels onto drawer brackets with a 7/32" hex wrench; BAG **WHEELS**.

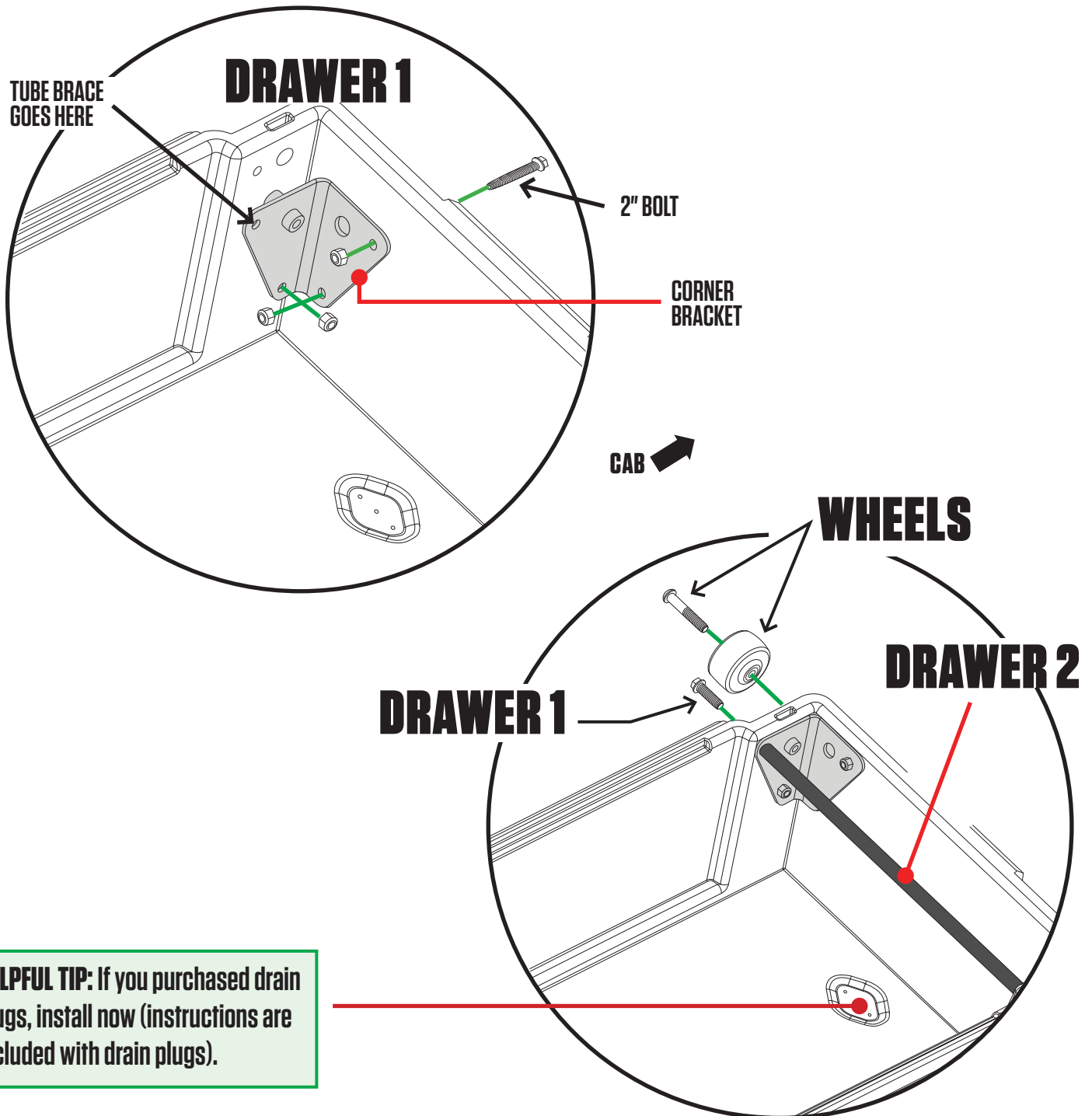

DRAWERS: AXLE WHEELS + WEATHERSTRIPS

- Slide narrow drawer into driver side drawer cavity. **NOTE: It is easier to fully install narrow drawer first.**
- **DETAIL A:** Install two tailgate wheels onto narrow drawer axles with a 7/32" hex wrench; **BAG WHEELS.**
- Repeat with wide drawer.
- **DETAIL B:** Install weatherstrips on top of drawer edges **WITH WIPER BLADE POINTING TOWARD DRIVER.**
IMPORTANT: Facing the weatherstrip the wrong way will funnel water into drawer: DUH!

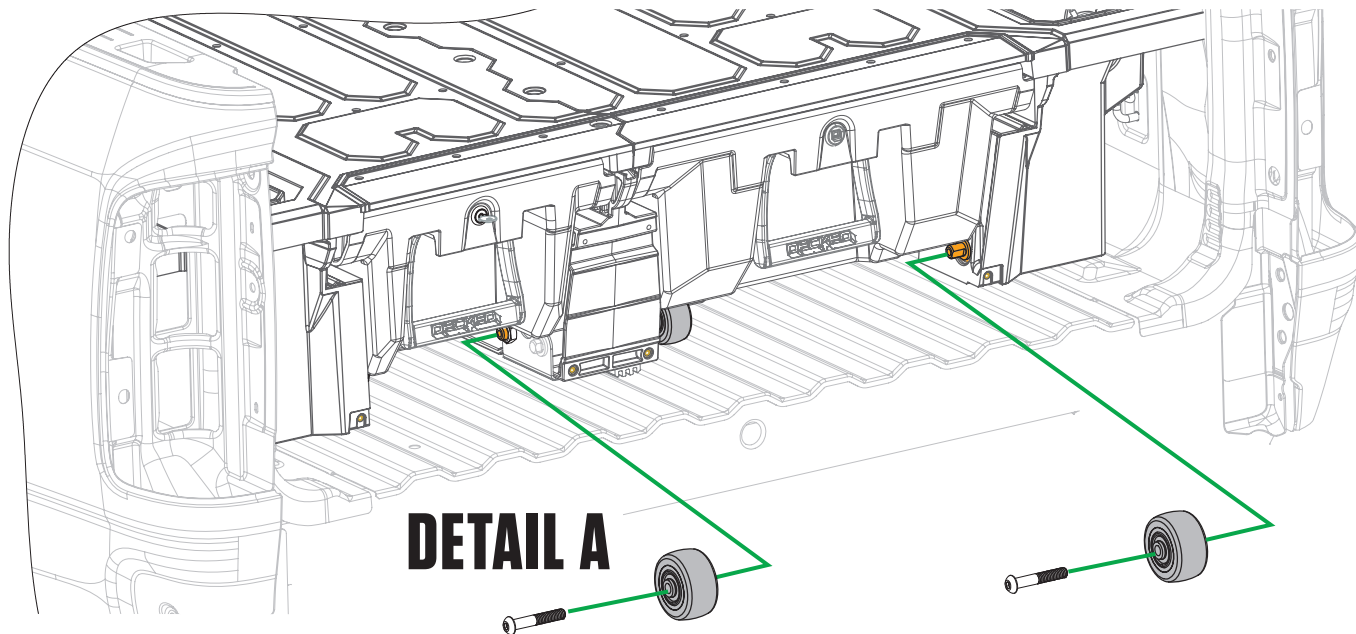

HELPFUL TIP: To make this step easier, jam a 2" piece of material under drawer, or get your pal to pinch the drawer up to the deck to give you better leverage.

HELPFUL TIP: Cut weatherstrips if they overhang.

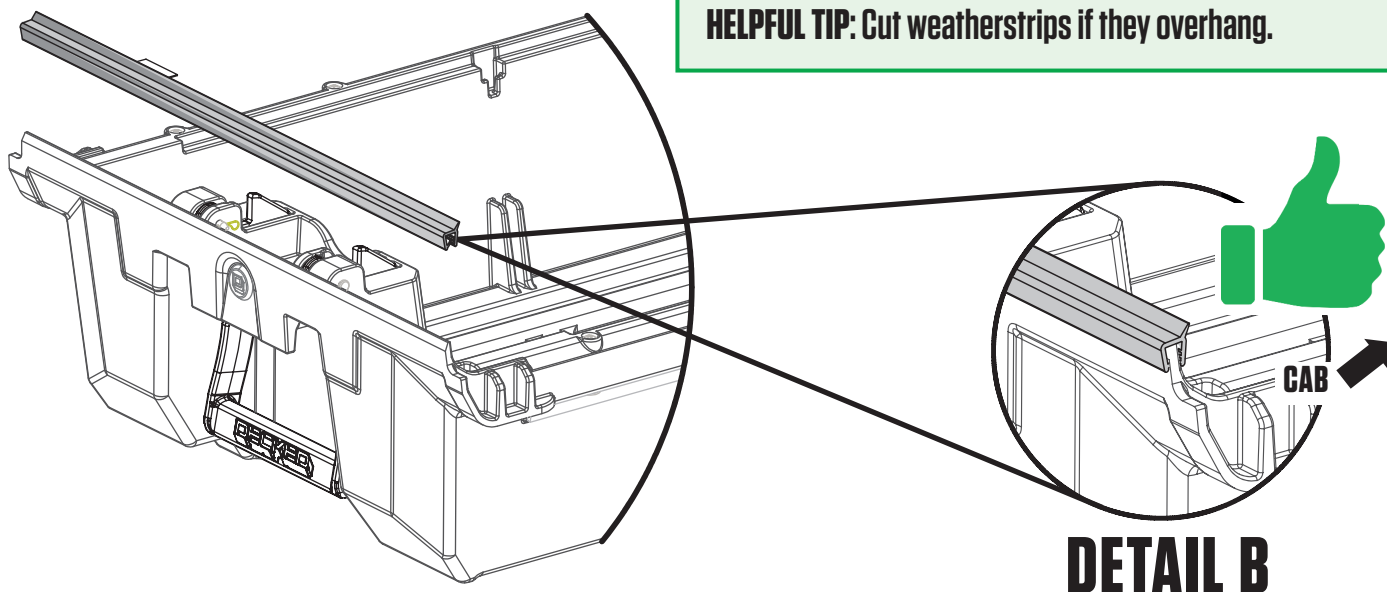

FINAL STEPS: TORSION BRACE + BOTTLE OPENER

- Slide torsion brace under center vert and tailgate ammo cans.

NOTE: If you jumped the gun and tightened the J-hooks when installing, loosen them.

- Loosely install:

- Two bolts with nylon washers through the end holes in torsion brace into ammo cans; BAG **S1**.
- Two bolts with nylon washers through the bottom bottle opener holes and torsion brace into center vert; BAG **S1**.
- Two 1/2" length bolts through upper holes in bottle opener into center vert; BAG **FINAL MID**.

- Align bottle opener to edges of center vert and tighten four bottle opener bolts.

- Tighten end bolts into tailgate ammo cans.

- **Finally.....Tighten the J-hooks! DO NOT OVER TIGHTEN, just make snug. Make sure the gap between the sidewall of the bed and the deck is equal on both sides.**

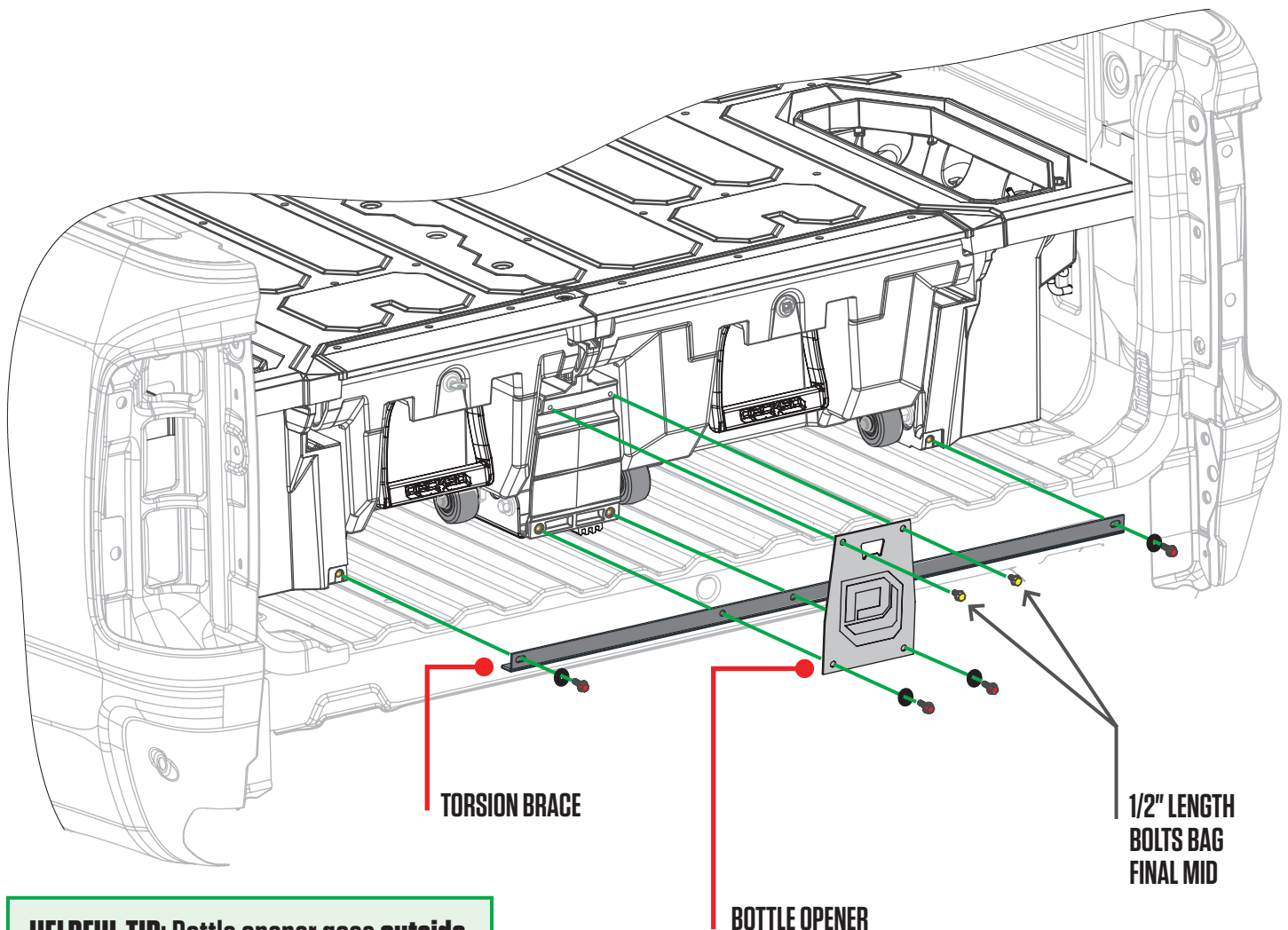

HELPFUL TIP: Bottle opener goes outside of torsion brace.

BAM BAM: THE RULER

- Center ruler in embossed area and screw three 1/2" length Phillips screws through the tailgate side holes directly into deck panels; BAG **FINAL MID**.

NOTE: These are small gauge screws. Tighten to a light snuggle **ONLY**.

- For the three cabside ruler mounting holes, drill each with a 9/64" bit and a drill stop set to 1/2". There is a lateral steel tube that runs on the underside of the deck at this location. (SEE UNDERSIDE VIEW OF DECK).

IMPORTANT: Only drill through **TOP** of steel tube; do not drill through bottom of tube, 'lest you want to pull a Niagara Falls and funnel water into your drawers.

- Screw three 3/4" length Phillips screws into the cabside ruler holes you just drilled; BAG **FINAL MID**.

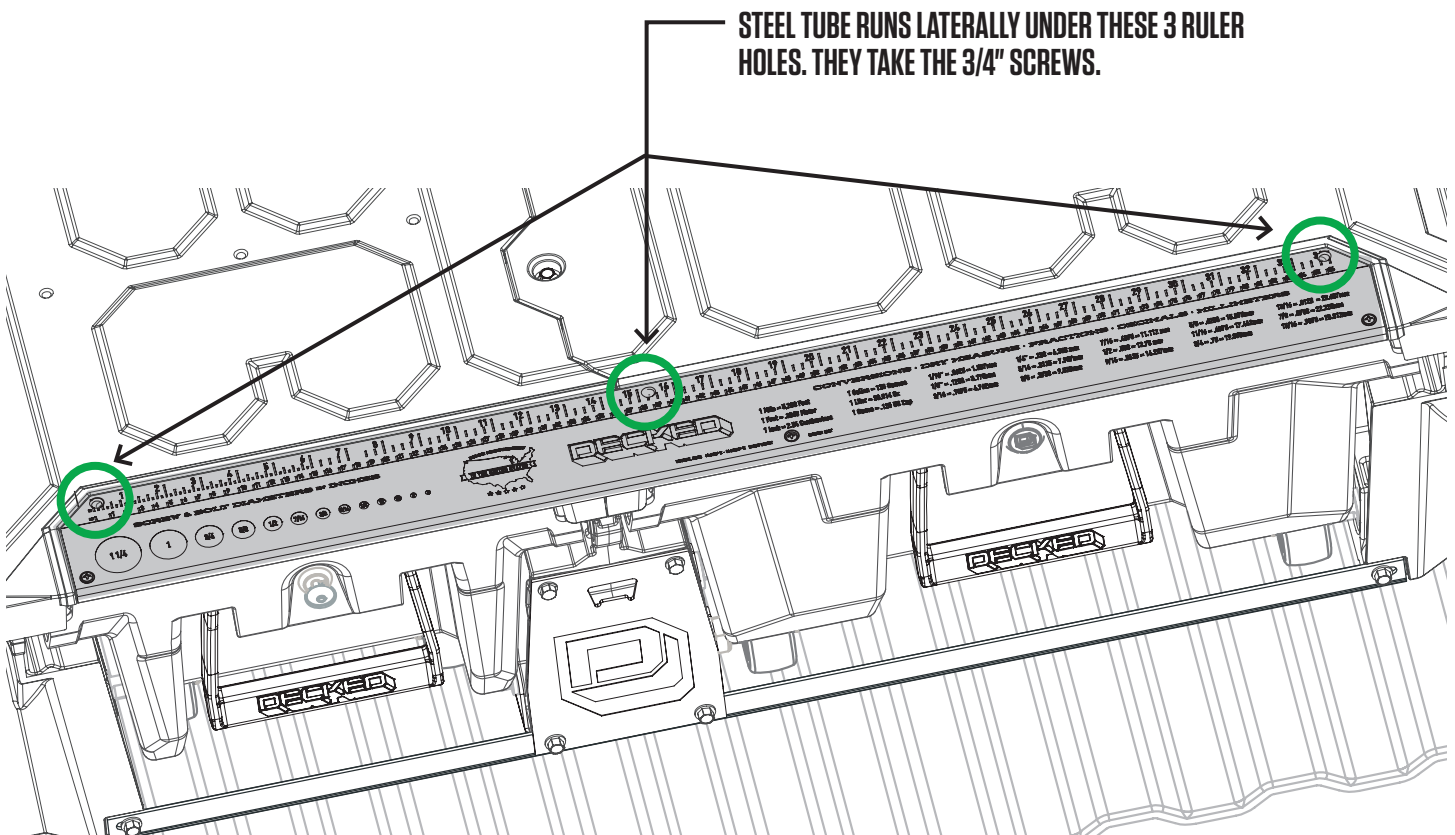

UNDERSIDE VIEW OF DECK

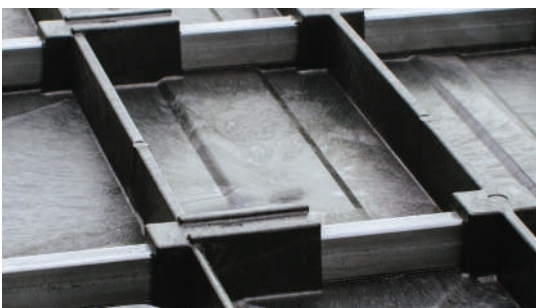

DO: Drill through the top of steel tube ONLY.

DO NOT: Drill through both sides of steel tube = **YOU'RE FIRED!**



FINAL STEPS: AMMO CAN LIDS

- **DETAIL A:** Ammo can lids are driver (marked L) and passenger (marked R) side specific.
- **DETAIL B:** Holding lid in orientation shown, insert tab on tailgate end of ammo can lid and push the cabside end of lid down to secure. Don't be afraid to give'r the Fonzi to close, it's rugged.
- Insert lock hole plugs, unless you ordered drawer locks! Install drawer locks now (instructions with locks); **BAG FINAL MID.**

IMPORTANT: Grab your favorite beverage, crack 'er open in the bottle opener and christen this ship! You did it. Immediately post a photo of your significant other, child or canine (in no order of significance) appreciating your accomplishment.

DETAIL A

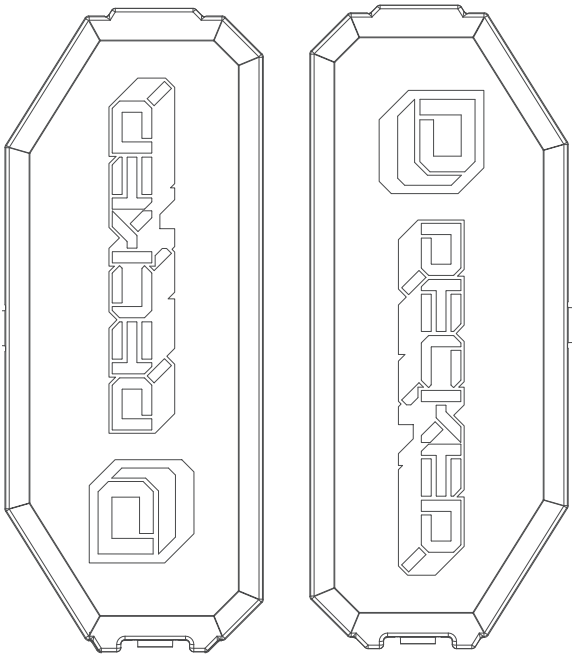

**DRIVER SIDE
AMMO CAN LID**

**PASSENGER SIDE
AMMO CAN LID**

DETAIL B

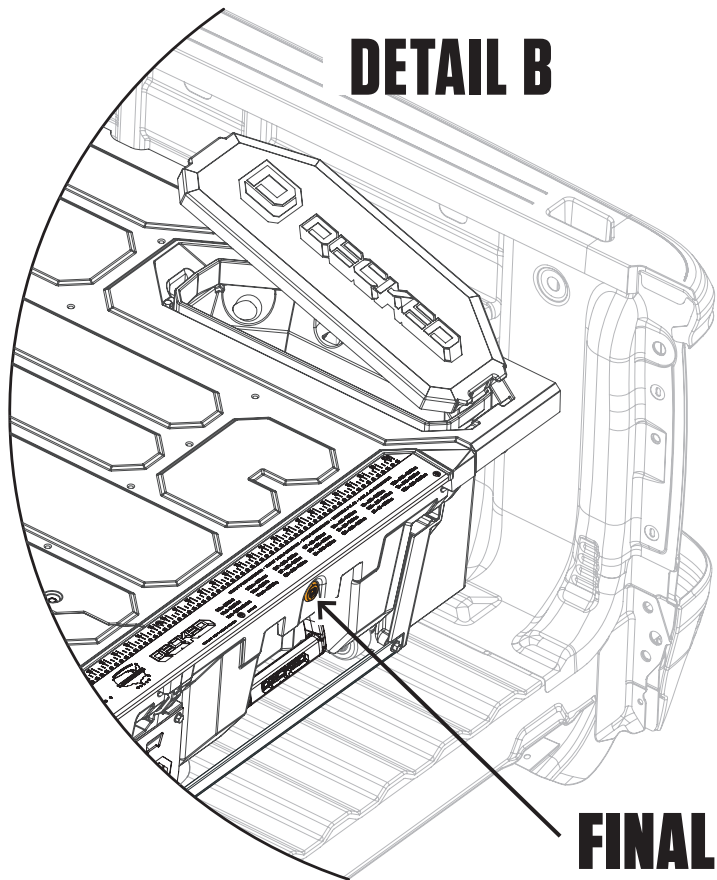

FINAL MID