



**Installation Instructions:  
DS2**

**FORD SUPER DUTY  
6'9" BED LENGTH  
2009-2016**

**TOOLS REQUIRED**

- **Adjustable wrench** (that opens to about 1")
- **1/2" open end wrench**
- **#2 Phillip screwdriver**
- **3/8" socket**
- **7/16" deep socket**
- **7/32" Allen wrench**
- **1/2" drill bit**
- **Wire cutters**
- **10 mm socket or open end wrench**

# CONTENTS

## DECKED carton

- LEFT/DRIVER deck half - 1
- RIGHT/PASSENGER deck half - 1
- Center vert - 1
- Drawer - 2
- Cabside ammo can - 2
- Tailgate side ammo can - 2
- Ammo can lid - 4
- Ammo can window - 2
- C-channel - 2
- Ruler - 1
- Hardware box - 1

## Hardware box - unbagged components

(inside DECKED carton):

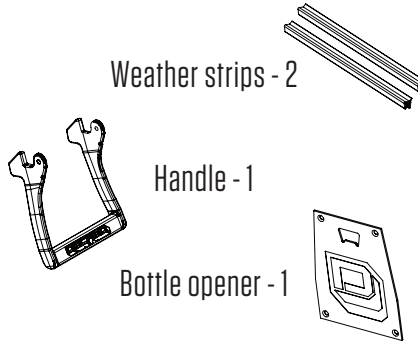

## HARDWARE box - bagged components

- PREP SD/TUN - 1
- C-CHANNEL HW - 1
- BOLT 1 FS - 1
- CS AMMO CANS - 1
- J8 - 2
- J10 - 2
- DRAWER 1 - 1
- DRAWER 3 - 1
- HANDLE - 1
- WHEELS - 1
- FINAL FS - 1
- PREP-EXTRA - 1

## ▼ ASSEMBLY OVERVIEW ▼

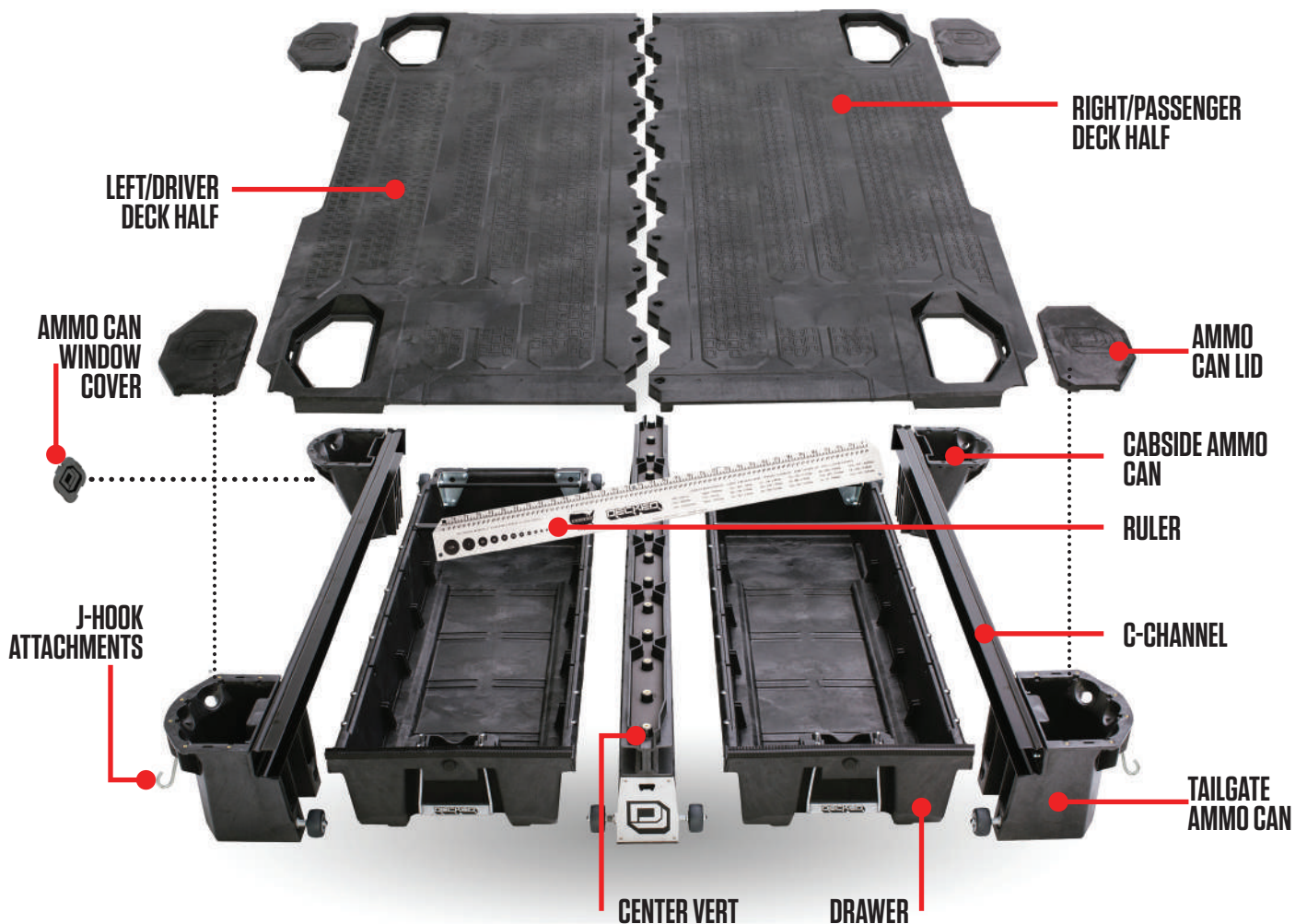

## ▼ HEY! TORQUE BOY: READ BEFORE YOU INSTALL DECKED ▼

1. **DON'T** be an idiot read the instructions.
2. **DON'T** over tighten bolts, get em' hand-tight.
3. **DON'T** use power tools.
4. If you don't follow directions and *do* use power tools:  
1). Set clutch at a very low setting. 2). If you blow it, see NOTE.\*
5. **DON'T** over tighten J-hooks during installation. Make 'em good and snug enough to keep the system from moving in the bed.
6. Nice job if you're still reading .

**NOTE\*** Two extra threaded inserts are included in **BAG PREP-EXTRA**. That's all you get. The inserts will replace any stripped inserts in the tailgate ammo cans, but NOT THE CENTER VERT, so hand tighten until snug only! You can also screw the inserts back in if dislocated. There is a straight screwdriver slot on the underside of the insert.

**TAILGATE** ammo cans have wide bottoms; **CABSIDE** ammo cans have narrow bottoms.

**NOTE:** You will need a buddy to help with exactly two steps, not including draining the sixpack or snapping pics of you posing.

*Prevent abusive, expletive-filled language, watch our detailed installation video or give us a call. We're happy to help!*

# AMMO CAN DRAIN HOLES

(TO DRILL OR NOT TO DRILL.)

## • Do you use a tonneau or shell over your DECKED system?

There is no need to drill holes.

## • Does your DECKED system live outside?

The ammo cans will get water in them. You'll need to drill holes in the ammo cans.

There are two dimples in the bottom of each ammo can. Drill a 1/2" hole at each dimple. A smaller hole will get clogged.



# PREP BED

(JUST LIKE YOUR MOMMA TAUGHT YOU.)

- Remove cabside factory tie-downs on both sides of truck bed (10 mm wrench required).  
Make sure to **SAVE THE FACTORY SUPER DUTY BOLTS**, as you will need them for the DECKED brackets.
- Install DECKED tie-down brackets on both sides of truck using bolts from step above; **BAG PREP SD/TUN.**

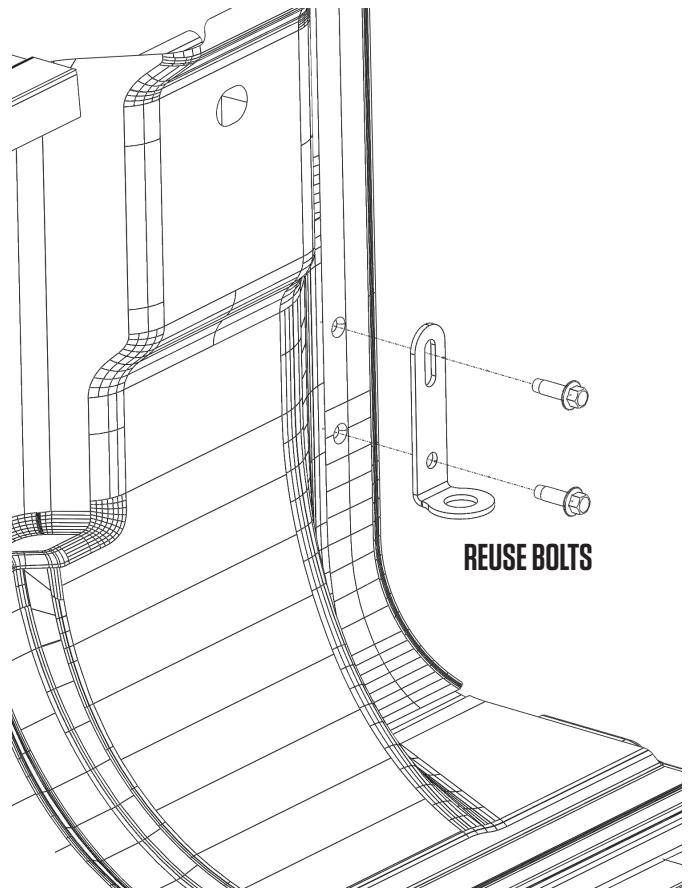
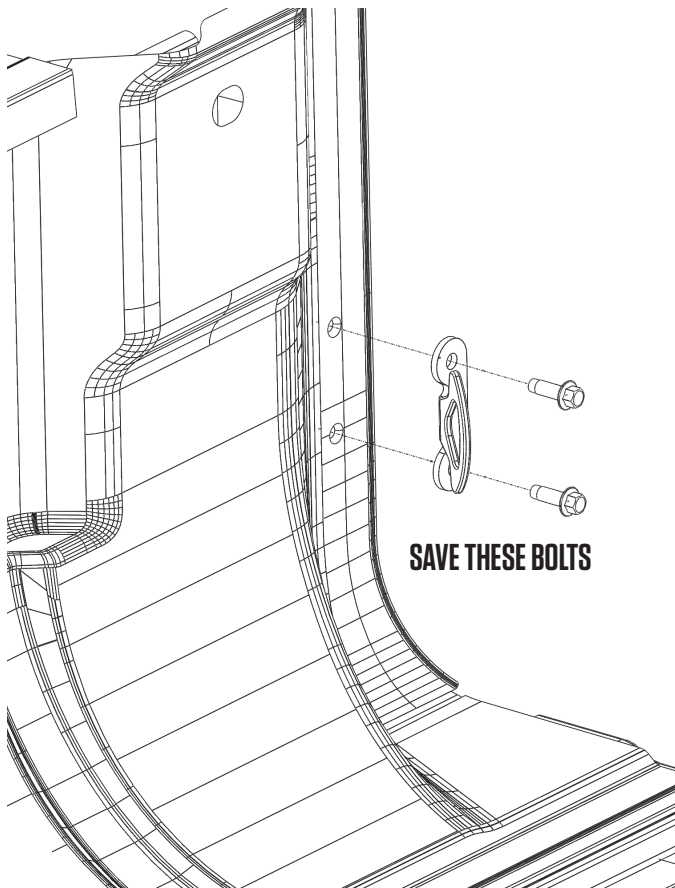

**PREP SD/TUN**

FACTORY TUNDRA  
TIE-DOWN BRACKETS

DECKED  
TIE-DOWN BRACKETS

# ASSEMBLY: DRIVER'S SIDE DECK

(LET'S DO THIS!)

- There are three pre-installed gaskets – one on the center vert, one on each underside of the decks where they rest on the center vert.
- Place C-channel on the **inside** ledges of a cabside ammo can and a tailgate ammo can.
- The end of the C-channel with the endplate must rest on the cabside ammo can.
- Verify that the tailgate ammo can's axle is closest to the tailgate; if not, grab the other tailgate ammo can.
- Loosely bolt C-channel to the two ammo cans. Make sure the bolt head is on the C-channel side, not inside the ammo can; **BAG C-CHANNEL HW**. Don't tighten yet.
- Line up the driver's side deck (sticker on end of deck panel indicates LEFT/DRIVER) on top of the C-channel/ammo can assembly and the center vert bosses. **NOTE: Tailgate side of the center vert has an axle installed; the center vert and ammo can axles must be on the tailgate end (not cabside end) of the assembly.**
- Bolt the deck to the ammo cans; **BAG B1** for the tailgate ammo can, **BAG CS AMMO CAN** for the cabside ammo can.
- **Now go back and tighten the loose bolts connecting the ammo cans to the C-channel.**
- Bolt the deck to the center vert; **BAG B1: Do not use power tools!**
- Grab your buddy to help you lift the assembly into the driver side of the truck bed.

## DRIVER SIDE DECK HALF

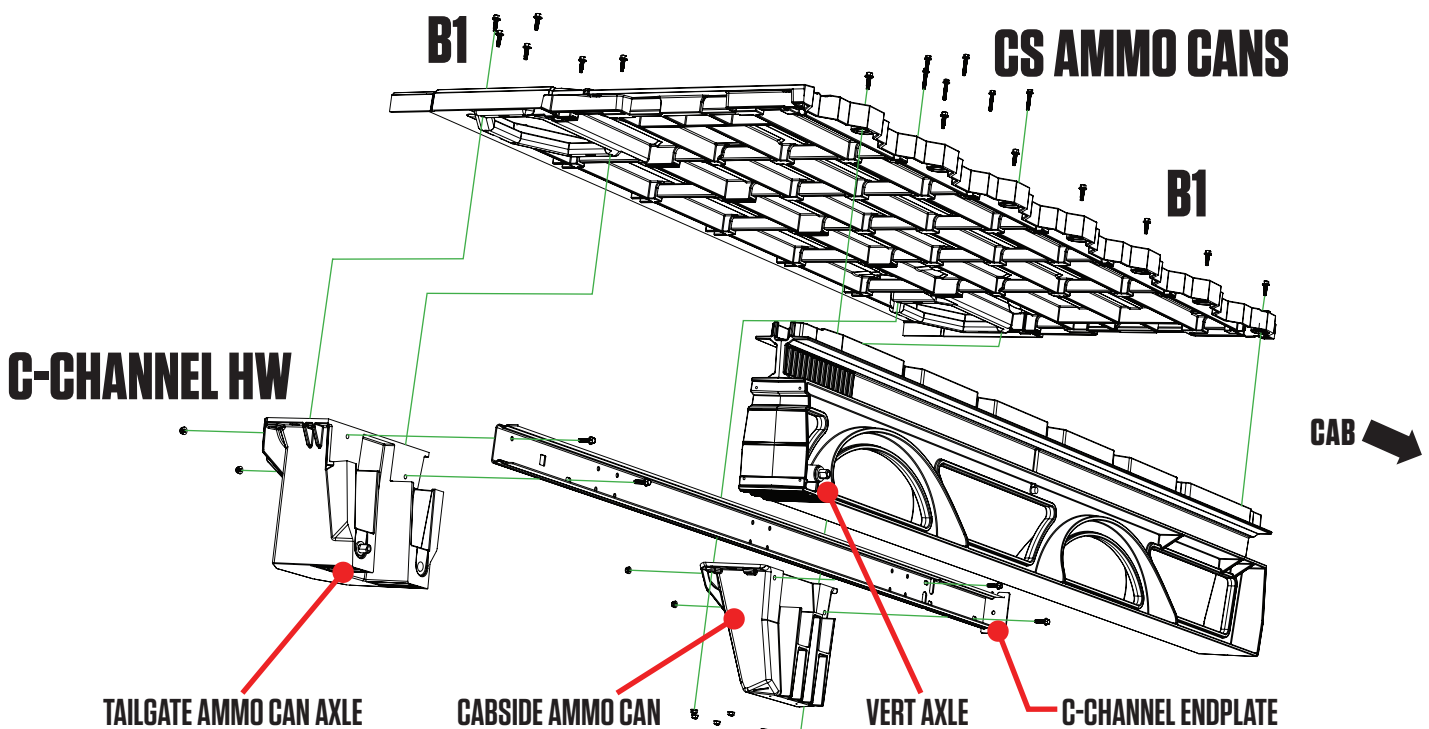

# ASSEMBLY: PASSENGER'S SIDE DECK

(NOW YOU'RE ACTUALLY GETTING SOMEWHERE!)

- Place C-channel on the **inside** ledges of a cabside ammo can and a tailgate ammo can.
- The end of the C-channel with the endplate must rest on the cabside ammo can.
- You should have the correct tailgate ammo can for this step. The axle will be on the tailgate side of the system. If not, swap the tailgate ammo cans now.
- Loosely bolt C-channel to the two ammo cans. Make sure the bolt head is on the C-channel side, not inside the ammo can; **BAG C-CHANNEL HW**. Don't tighten yet.
- Line up the passenger's side deck (sticker on end of deck panel indicates RIGHT/PASSENGER) on top of the C-channel/ammo can assembly.
- Bolt the deck to the ammo cans; **BAG B1** for the tailgate ammo can, **BAG CS AMMO CAN** for the cabside ammo can.
- **Now go back and tighten the loose bolts connecting the ammo cans to the C-channel.**
- Grab your buddy to help you lift the assembly into the passenger side of the truck bed.

## PASSENGER SIDE DECK HALF

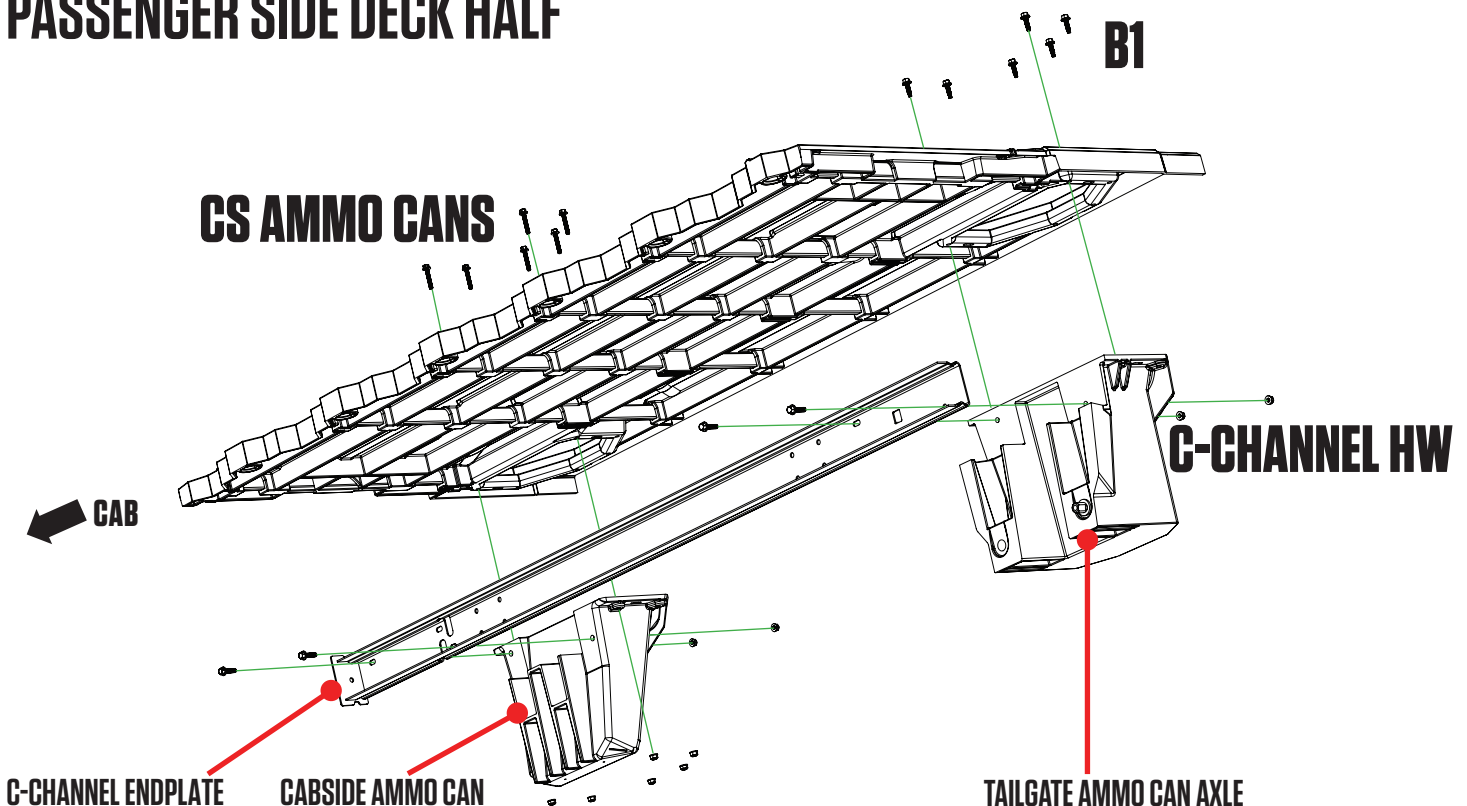



# INSTALL: PASSENGER'S SIDE DECK HALF

(OK, FINE, PAT YOURSELF ON THE BACK)

- Seat passenger side deck on the upstanding vert bosses.
- Bolt the passenger side deck half to the center vert; **BAG B1**. Make sure all bolts connecting the deck to the center vert are snug, **but no power tools**.
- Insert the J-hook through the **tailgate** hole on the passenger side tailgate ammo can and loop J-hook through tie down or mounting bracket in bed. Assemble with black spherical washer, flat washer and nut; **BAG J10**. Don't tighten yet. If you do, you won't be able to center the system properly in your bed.
- Insert the J-hook through **cabside** hole on the passenger side cabside ammo can and loop J-hook through tie down or mounting bracket in bed. Assemble with black spherical washer, flat washer and nut; **BAG J8**. Don't tighten yet. **IMPORTANT: Leave all J-hook nuts loose until entire deck is in place.**

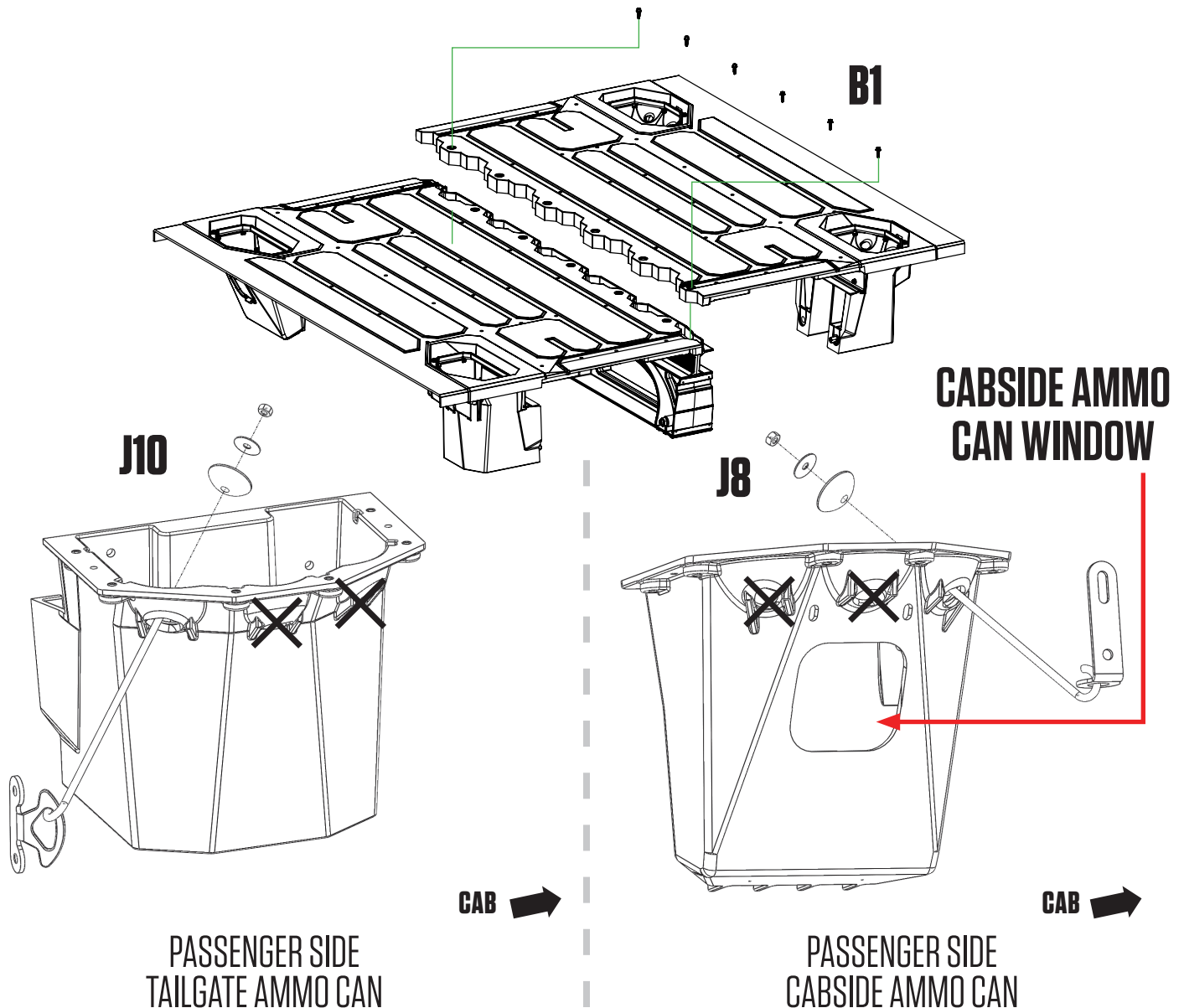

# INSTALL: DRIVER'S SIDE DECK HALF

- Insert the J-hook through the **cabside** hole on the driver side cabside ammo can and loop J-hook through tie down or mounting bracket in bed. Assemble with black spherical washer, flat washer and nut; **BAG J8**. Don't tighten yet.
- Insert the J-hook through the **tailgate** hole on the driver side tailgate ammo can and loop J-hook through tie down or mounting bracket in bed. Assemble with black spherical washer, flat washer and nut; **BAG J10**. Don't tighten yet.

**MAKE SURE THE CENTER VERT IS IN THE CENTER OF YOUR BED; the gaps on either sidewall may not be equal because the world isn't perfect and neither is your truck bed.**

- Alternately and gradually tighten all J-hooks to ensure DECKED is centered and secure. **Do not tighten one side of J-hooks all the way in one step. DO NOT OVERTIGHTEN J-HOOKS!**

**NOTE: If the DECKED system is noticeably "crowned", the J-hooks are too tight.**

- Install the window covers in the cabside ammo cans (from inside the ammo can).

**CABSIDE AMMO  
CAN WINDOW**

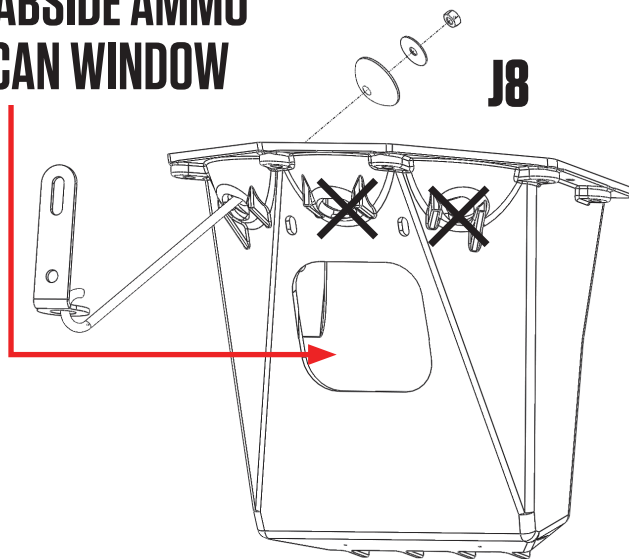

**J8**

**← CAB**

**DRIVER SIDE  
CABSIDE AMMO CAN**

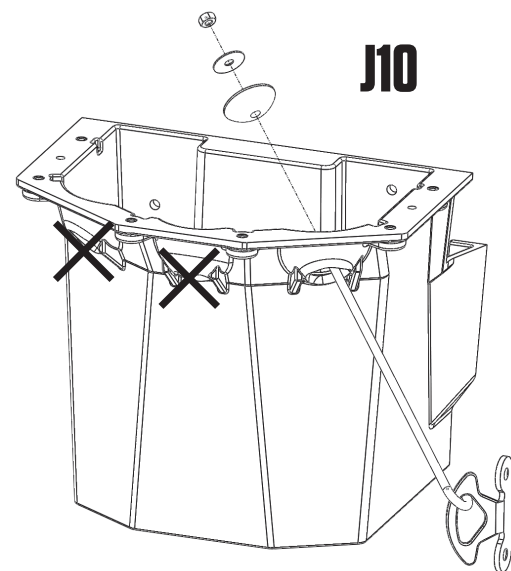

**J10**

**← CAB**

**DRIVER SIDE  
TAILGATE AMMO CAN**



# DRAWERS: BRACKETS + WHEELS

(SO EASY A CHIMPANZEE CAN DO IT)

- Each drawer has a left and a right bracket. Bolt the brackets into place via bottom two holes in bracket with 3/4" length bolts. Use the 2" length bolt for the upper cabside wall hole in bracket; **BAG DRAWER 1**.
- Install a tube brace in each drawer with two 3/4" length bolts; **BAG DRAWER 1, BAG DRAWER 3**.
- Attach wheels onto the drawer brackets with a 7/32" hex wrench; **BAG WHEELS**.

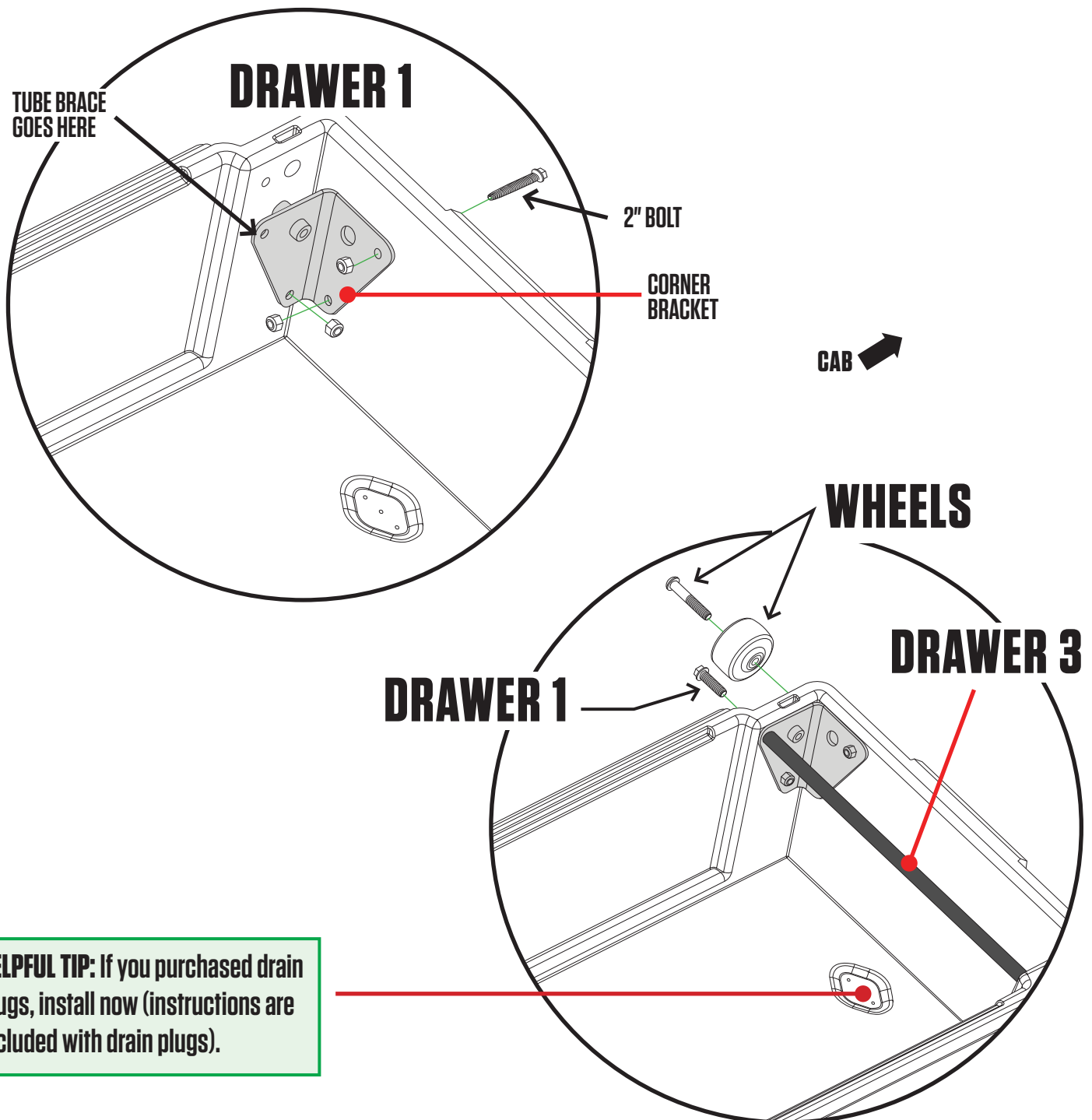

# INSTALL: DRAWER HANDLES

- One drawer handle assembly needs to be installed.
- From the **underside** of drawer, place the springs into the cavities on either side of the handle slots, red spring=right spring; **BAG HANDLE**. **NOTE: Each spring arm should point inward, not outward.**
- Install a clevis pin through each outside drawer hole and through spring; **BAG HANDLE**.
- With **DECKED** logo facing outward, insert the handle ends behind the spring arms. Rotate the arms of the handle toward the clevis pins, pulling the spring arm downward. When the handle hole is lined up with the clevis pin, push the pin through the handle hole and through the inside drawer hole. Repeat on the other side of the handle.
- Install a hair pin through the clevis pin; **BAG HANDLE**.

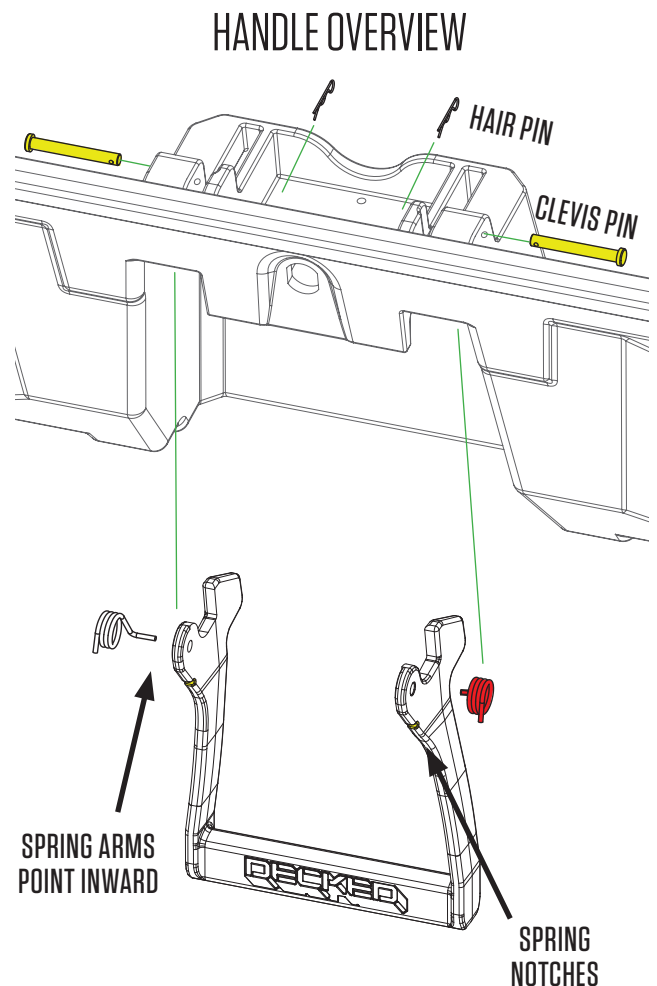
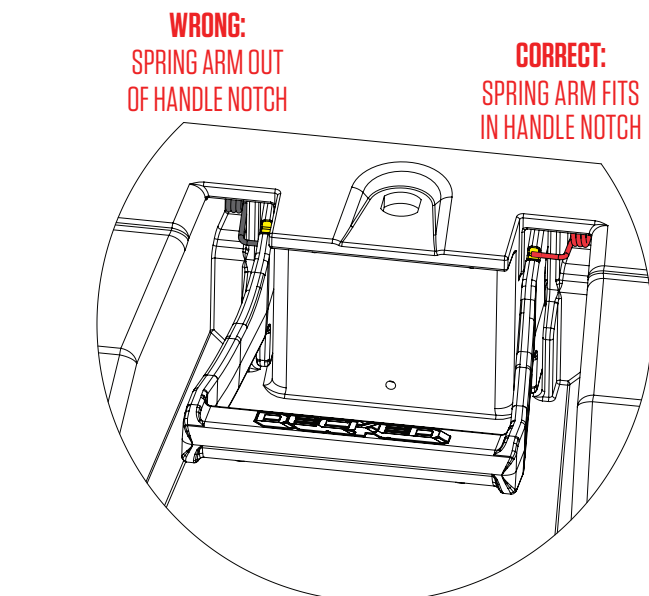
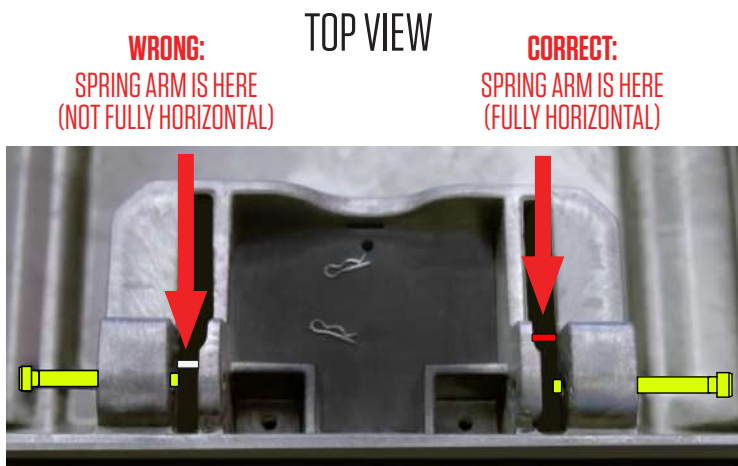

**HELPFUL TIP:** MAKE SURE SPRINGS HAVE THE LONG ARM HORIZONTAL AND SHORT LEG VERTICAL BEFORE INSERTING HANDLE



# INSTALL: DRAWERS

(HOPEFULLY YOU'RE STILL WEARING YOURS.)

- Install the drawer by sliding wheels into their two channels (C-channel and center vert), and slide drawer all the way forward until closed.
- Install the remaining tailgate side wheels onto their axles; **BAG WHEELS**.

**NOTE: Placing a spacer under the drawer to raise it into position makes this easier (ammo can lids work well, or a small piece of 2x2 or 2x4 is even better).**

- Install the weather strips on the tailgate side drawer edge: With the weatherstrip wiper facing cabside, line up one end with the side of the drawer and place on the top drawer edge, firmly pressing down on the weatherstrip as you move along the drawer edge.

**NOTE: Facing the weather stripping the wrong way will funnel water into drawer: BAD!**

- When the weatherstrip is fully seated along the top edge, trim off any that extends beyond the drawer edge with wire cutters. Watch out for the stainless wire coil inside; it's sharp!

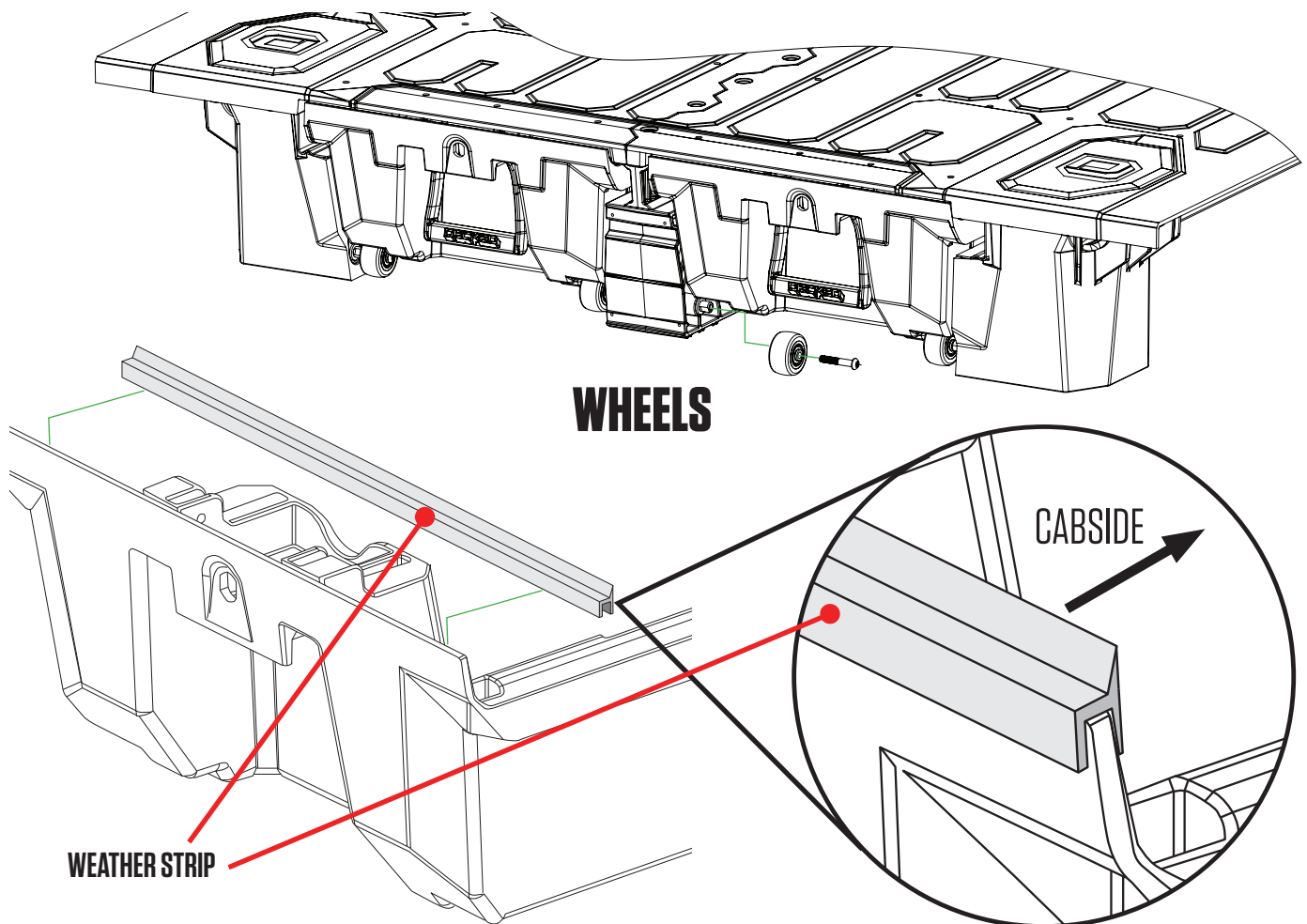

# INSTALL: THE FUN STUFF

(PARTY TIME!)

**CAUTION:** These are small gauge screws – light, hand-tightening is all that is required.

- Center and screw on the ruler/edge guard; **BAG FINAL FS**.
- Screw on the bottle opener; **BAG FINAL FS**.
- Install lock core plugs; **BAG FINAL FS**, or install locks if purchased.

**IMPORTANT:** Grab your favorite beverage, crack 'er open in the bottle opener and make a toast to your truck. You did it. Immediately post a photo of your significant other, child or canine (in no order of significance - please someone show us your pet alligator) appreciating your accomplishment. Add hashtag #DECKEDUSA | @DECKEDUSA.

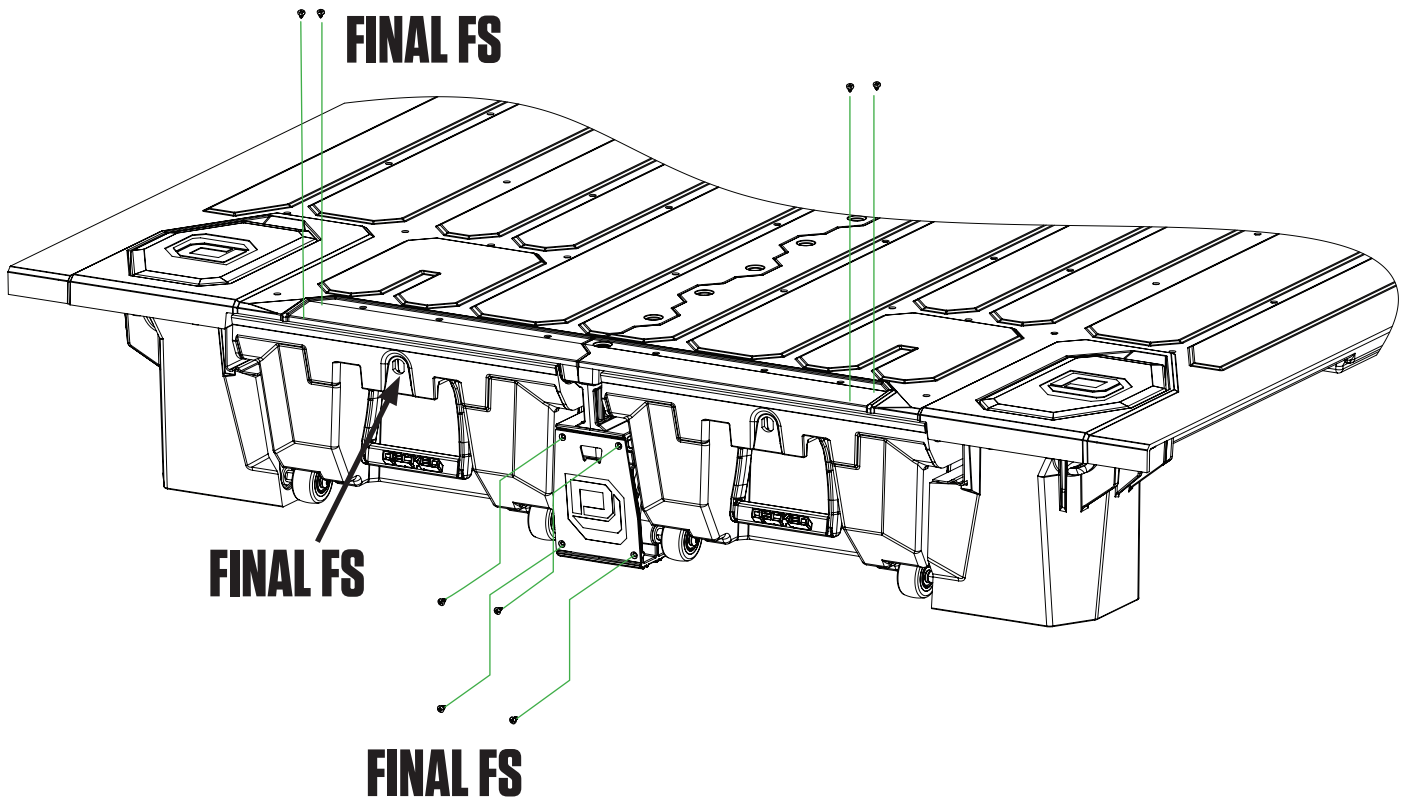

Check out the collection of truck bed accessories we offer.