

In-Tank Pump DW300c (9-307, 9-309)



PN 9-307 represented in above photo

The 340lph DW300c offers the highest flow available in a compact fitment pump. The compact fitment allows drop-in fitment into many popular applications such as WRX, R35 GTR, EvoX, CTS-V2, and BRZ/FRS. Quiet operation and pulse width modulation compatibility are delivered via the turbine impeller and computer balanced armature. E85 compatibility is built in via the carbon commutators and a fully encapsulated armature.

Specifications

Weight	10.2 oz (290grams)
External Materials	Electroplated Steel
Inlet Fitting	7.7mm ID, 11.0mm OD
Outlet Fitting	5/16" Hose Clamp
PRV Activation	100 psi
Impeller Design	Single Scroll Composite Turbine
Connector Terminal	Spade Pos/Neg
Min Voltage Input	6 Volts
Max Voltage Input	18 Volts
Current Draw 40psi	11.7 amps (13.5v)

Delivery Characteristics

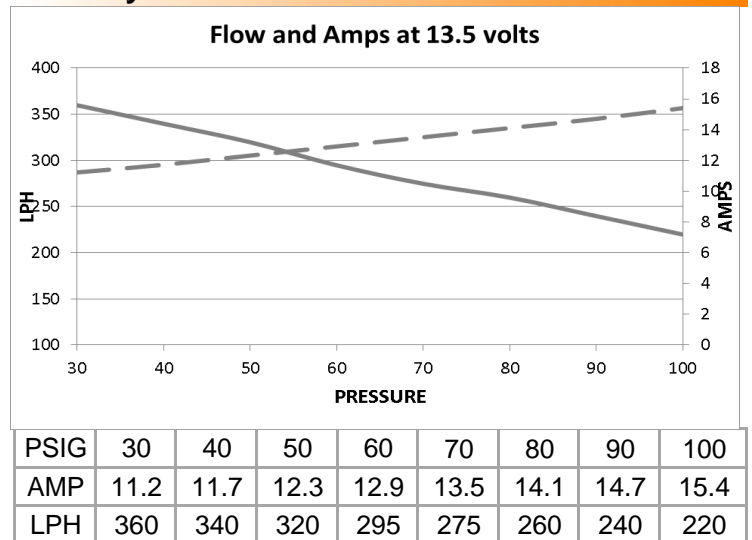

Dimensions

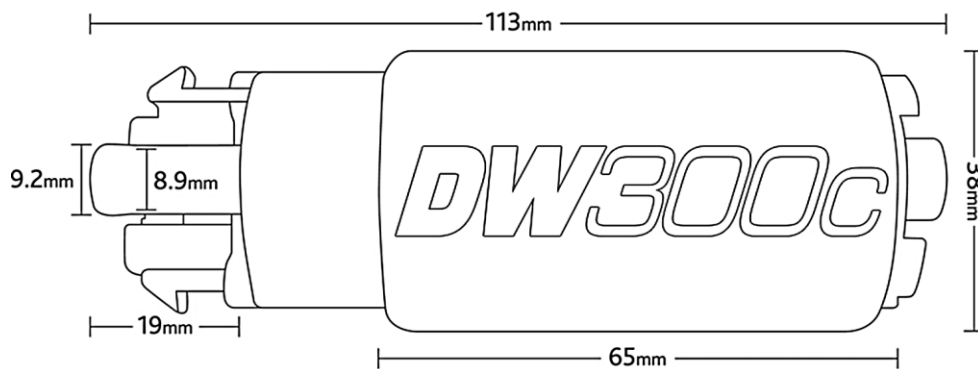

PN 9-309 represented in above technical drawing

THIS PRODUCT MAY BE USED SOLELY ON VEHICLES USED IN SANCTIONED COMPETITION WHICH MAY NEVER BE USED UPON A PUBLIC ROAD OR HIGHWAY, UNLESS PERMITTED BY SPECIFIC REGULATORY EXEMPTION