

In-Tank Pump DW300m (9-305)



This 340lph DW300m is the only 300+ LPH pump with drop-in fitment for the Ford Mustang GT, and the GT500 dual pump module. To achieve Ford-specific fitment, we engineered this pump to replicate the OE's unique compact size, end cap geometries, electrical connector, and outlet barb. The result is a 340LPH pump that precisely installs into Ford modules with no wire splicing, no hacking, and no zip-ties. A single DW300m will support over 500hp on any 2v/3v mustang. In addition the DW300m is compatible with pulse with modulated pump drivers and is fully compatible with ethanol blended fuels. All DW fuel pumps are backed by a 3-year no fault warranty.

Specifications

| | |
|---------------------------|---------------------------------|
| Weight | 10.6oz (300g) |
| External Materials | Electroplated Steel |
| Inlet Fitting | 7.7mm ID, 11.0mm OD |
| Outlet Fitting | 5/16" Hose Clamp |
| PRV Activation | 100 psi |
| Impeller Design | Single Scroll Composite Turbine |
| Connector Terminal | Spade Pos/Neg |
| Min Voltage Input | 6 Volts |
| Max Voltage Input | 18 Volts |
| Current Draw 40psi | 11.2 Amps (13.5v) |

Delivery Characteristics

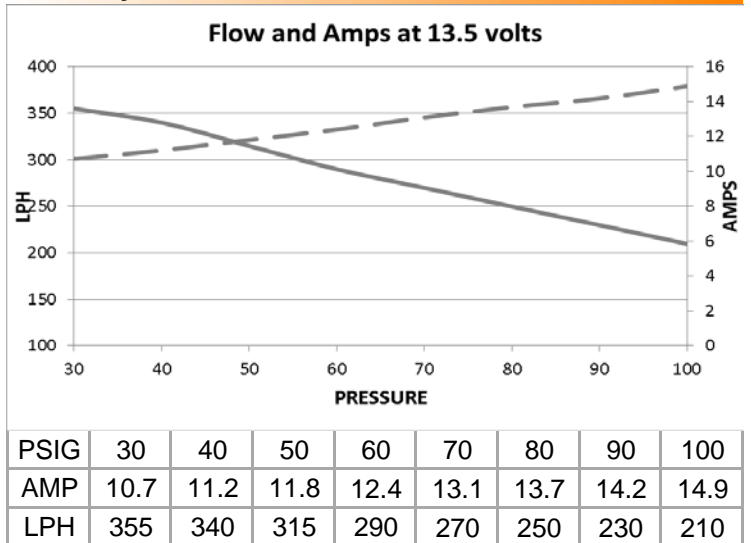

Dimensions

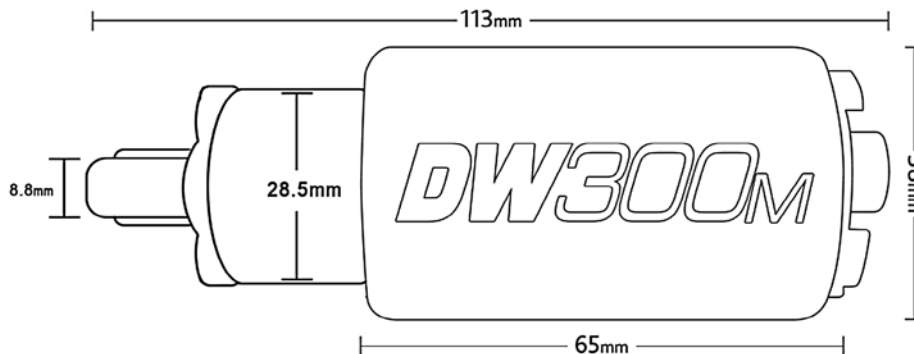

THIS PRODUCT MAY BE USED SOLELY ON VEHICLES USED IN SANCTIONED COMPETITION WHICH MAY NEVER BE USED UPON A PUBLIC ROAD OR HIGHWAY, UNLESS PERMITTED BY SPECIFIC REGULATORY EXEMPTION

Discover other performance fuel system parts on our website.