



dB Performance Exhaust System Installation
Cat-Back Exhaust System
Single Side Exit w/ 4" Slash Cut Tip
2009+ 4.8L & 5.3L GMT900 Chevy Silverado/GMC Sierra
2009 133" WB Part # 24902 2009 143.5" WB Part # 24904
2010 143.5" WB Part # 24905 2009+ 119" WB Part # 24920

Please take time to read and understand these installation instructions.

We recommend that the installation of this system be performed by a qualified service center or professional muffler installer who has the necessary equipment, tools and experienced personnel. However, if you decide to perform this install, the use of a hoist and an additional person will be required.

CAUTION: Never work on a hot exhaust system. Allow time for the vehicle to cool. Always wear eye protection when working under a vehicle.

Recommended Tools:

- Tape measure
- Black marking pen
- 13mm, 15mm socket and ratchet
- Chain style pipe cutter
- Grommet pullers
- Soapy water
- Safety glasses
- Torque Wrench

Please confirm that all parts are present before beginning the factory exhaust system removal and dB Performance Exhaust system installation.

Part # 24902 Bill of Materials:

- 1- 16SE4338 (Head Pipe Assembly)
- 2- 16SE2024 (dB Muffler Assembly)
- 3- 16SE4307 (Tailpipe Assembly)
- 4- 16SE3023 (dB Slash Cut Tip)
- 5- 20FF7030 (Hardware Kit)

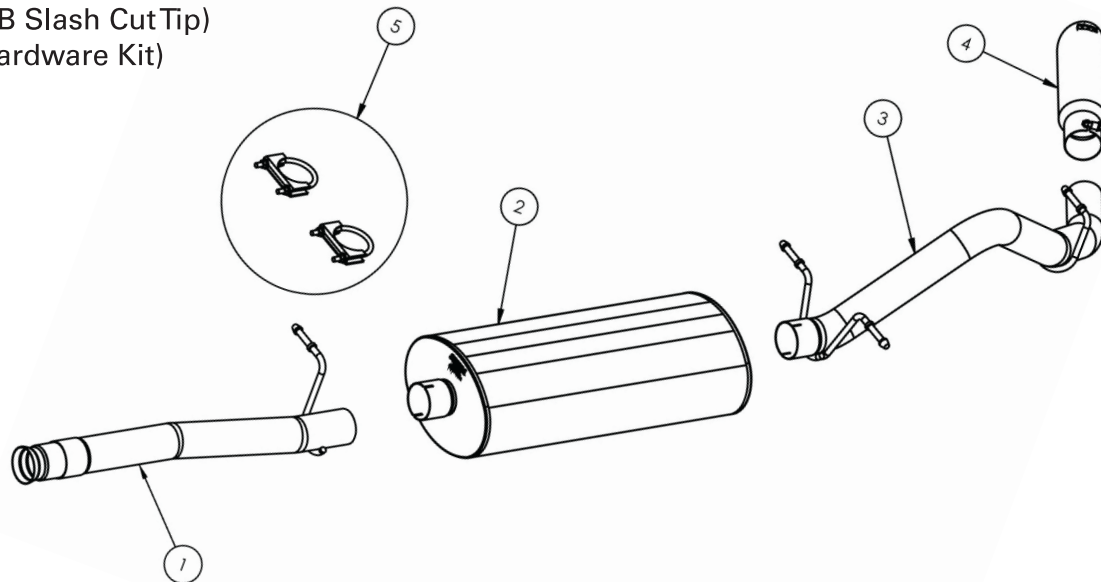



dB Performance Exhaust System Installation
 Cat-Back Exhaust System
 Single Side Exit w/ 4" Slash Cut Tip
2009+ 4.8L & 5.3L GMT900 Chevy Silverado/GMC Sierra
2009 133" WB Part # 24902 2009 143.5" WB Part # 24904
2010 143.5" WB Part # 24905 2009+ 119" WB Part # 24920

Part # 24904 Bill of Materials:

- 1- 16SE4332 (Head Pipe Assembly)
- 2- 16SE2024 (dB Muffler Assembly)
- 3- 16SE4307 (Tailpipe Assembly)
- 4- 16SE3023 (dB Slash Cut Tip)
- 5- 20FF7030 (Hardware Kit)

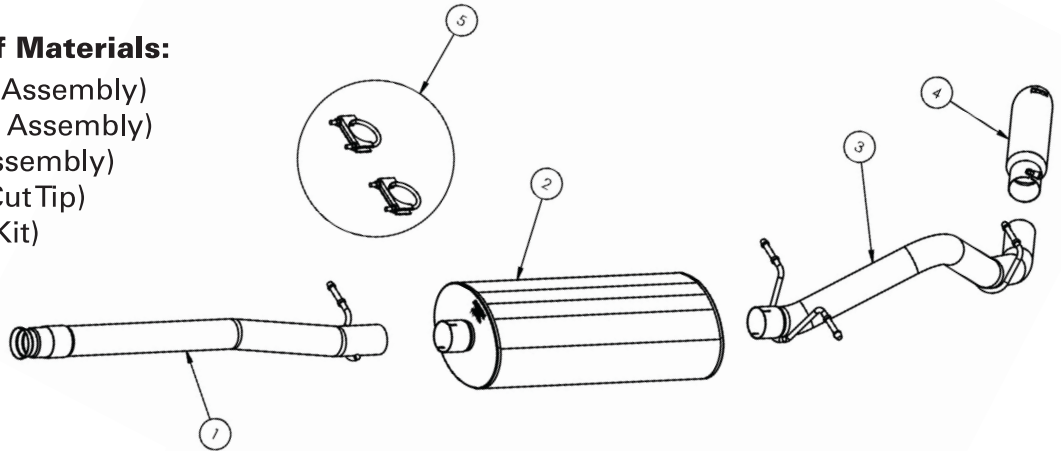

Part # 24905 Bill of Materials:

- 1- 16SE4345 (Head Pipe Assembly)
- 2- 16SE2024 (dB Muffler Assembly)
- 3- 16SE4307 (Tailpipe Assembly)
- 4- 16SE3023 (dB Slash Cut Tip)
- 5- 20FF7030 (Hardware Kit)

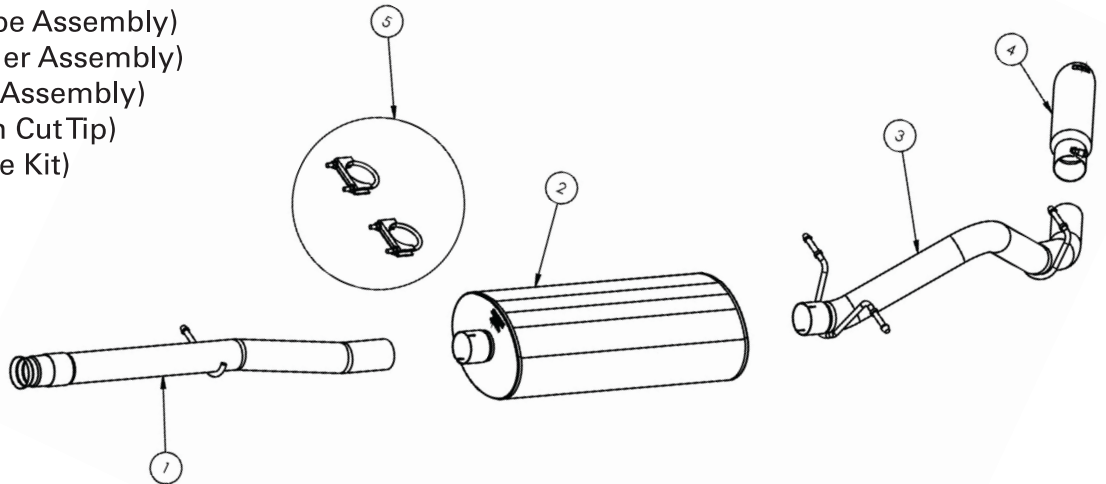

Part # 24920 Bill of Materials:

- 1- 16SE4391 (Head Pipe Assembly)
- 2- 16SE2024 (dB Muffler Assembly)
- 3- 16SE4307 (Tailpipe Assembly)
- 4- 16SE3023 (dB Slash Cut Tip)
- 5- 20FF7030 (Hardware Kit)

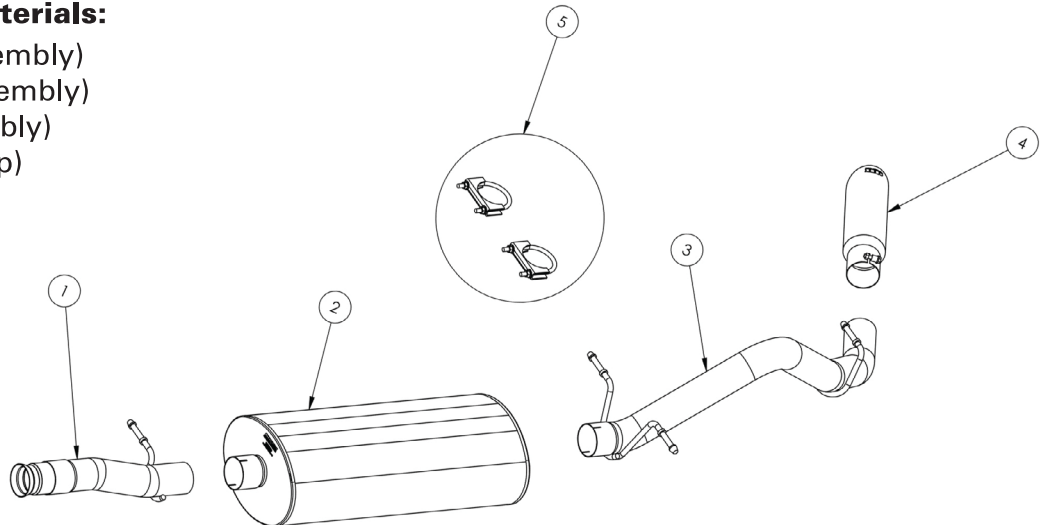

Removal of Stock System:

- 1) Scribe a line 12" from the front face of the stock muffler. **(See Fig. A)**
- 2) Place a chain style cutter around the exhaust pipe at the scribe line location and cut the exhaust pipe. **(See Fig. B)**
- 3) Remove the grommets from the tailpipe hangers at the muffler exit, the spare tire and finally ahead of the muffler, using grommet pullers or similar device. **(See Fig's C, D & E)**
Note: Using a soapy solution on the grommet hole will make the job easier.
- 4) Use a 13mm socket to loosen spherical clamp and remove factory headpipe. **(See Fig. F)**
- 5) Remove the muffler and rear tailpipe section from the vehicle by lifting the tailpipe over the rear axle and forwards toward the front of the vehicle. **(See Fig's G & H)** This completes the removal of the stock system.



FIG. A



FIG. B



FIG. C



FIG. D



FIG. E



FIG. F



FIG. G



FIG. H

Installation of dB Performance Exhaust System:

NOTE: The supplied double edge clamps in this system will crush and permanently deform the exhaust piping as they are tightened. **DO NOT** tighten these clamps any more than is necessary to lightly hold the exhaust components in place, until the very end of this installation process. It will be difficult or impossible to make any positional or rotational adjustments to the exhaust system after these clamps have been tightened down.

VERY IMPORTANT: Align all clamps so that the open edge of the clamp bracket is parallel and aligned with the notch in the pipe, and the outside edge of the clamp bracket is approximately 1/8" from the end of the pipe expansion. (See Fig. 1) Failure to properly position or orient the clamps could result in a weak clamping load, or even a potential leak at the clamp joints.

IMPORTANT: Make sure that the small drain holes in the muffler are facing down when the muffler is installed. (See Fig. 2)

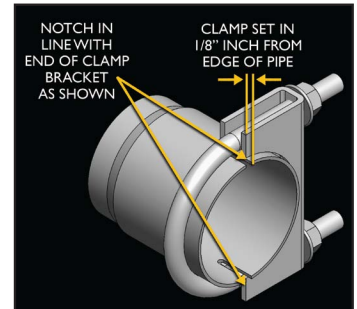

FIG. 1



FIG. 2

- 1) Locate the dB Head Pipe assembly and slide the spherical joint onto the factory pipe. Reuse the factory spherical clamp and loosely snug the spherical joint. Insert the hanger into the factory grommet. **(See Fig. H)**

Note: Using a soapy solution on the grommet hole will make the job easier.

- 2) Locate the dB muffler and make sure the weep hole is facing down. Then slide the muffler onto the Head Pipe. Slide a supplied 3" clamp over the inlet of the dB muffler and pre-tighten the clamp. **(See Fig's I, J & K)**



FIG. H



FIG. I



FIG. J



FIG. K



dB Performance Exhaust System Installation
Cat-Back Exhaust System
Single Side Exit w/ 4" Slash Cut Tip
2009+ 4.8L & 5.3L GMT900 Chevy Silverado/GMC Sierra
2009 133" WB Part # 24902 2009 143.5" WB Part # 24904
2010 143.5" WB Part # 24905 2009+ 119" WB Part # 24920

- 3) Slide a supplied 3" clamp over the inlet of the dB Tailpipe. From the rear of the vehicle slide the pipe over the axle while holding the rear differential vent hose out of the way. Insert the pipe over the muffler exit and place the hangers into the factory grommets. Pre-tighten the clamp. **(See Fig's L, M, N & O)**
Note: Using a soapy solution on the grommet hole will make the job easier.
- 4) Locate the dB Performance straight tip assembly, which has a clamp built into it. Slide the clamp end of the tip onto the end of the tailpipe. **(See Fig. P)** Rotate the tip until the dB Performance logo is centered on the top side of the tip. **(See Fig. Q)** Snugly tighten the clamp as shown using a 15mm socket and ratchet, making sure to only tighten the clamp enough to hold the tip in place on the tailpipe. **(See Fig. R)**
- 5) Adjust all dB components to attain clearance to surrounding parts. Starting from the front of the dB exhaust system, tighten all spherical clamps to **21 ft.-lbs**, nuts on all U-bolt clamps to **35 ft.-lbs** and tip clamp to **16-20 ft.-lbs**.
- 6) **It is strongly suggested that all clamps be checked and tightened after road testing the vehicle once the system has cooled.**



FIG. L



FIG. M



FIG. N



FIG. O



FIG. P



FIG. Q



FIG. R