



dB Performance Exhaust System Installation
Cat-Back Exhaust System
Single Side Exit w/ 4" Slash Cut Tip
Chevy Silverado/GMC Sierra 2500HD Gas
2002-06 Crew Cab/Short Bed 6.0L - Part # 24296
2003-06 Ext. Cab/Short Bed 6.0L - Part # 24292

Please take time to read and understand these installation instructions.

We recommend that the installation of this system be performed by a qualified service center or professional muffler installer who has the necessary equipment, tools and experienced personnel. However, if you decide to perform this install, the use of a hoist and an additional person will be required.

CAUTION: Never work on a hot exhaust system. Allow time for the vehicle to cool. Always wear eye protection when working under a vehicle.

Please confirm that all parts are present before beginning the factory exhaust system removal and dB Performance Exhaust system installation.

Recommended Tools:

- Safety Glasses
- 15mm Wrench or Deep Socket
- Torque Wrench
- Soap & Water Solution
- Saw or Chain-Style Pipe Cutter

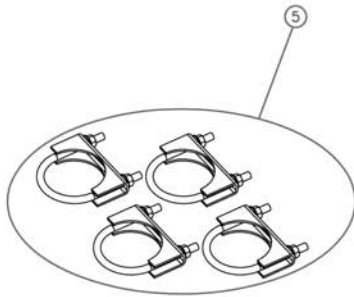

Part #24296

Bill of Materials:

- 1- Intermediate "Y" Pipe Assembly (16SE4089)
- 2- Muffler Assembly (16SE2025)
- 3- Tailpipe (16SE4284)
- 4- dB Performance Tip (16SE3023)
- 5- Hardware Kit (16SE7237)

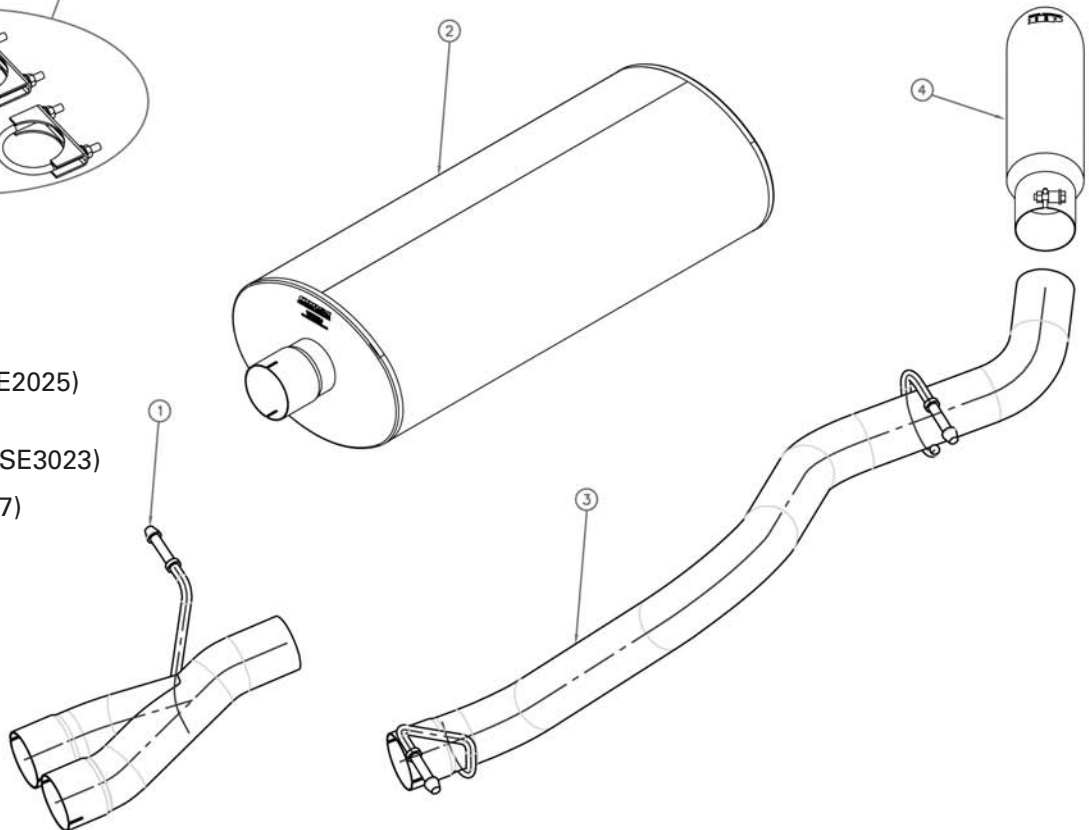



dB Performance Exhaust System Installation
 Cat-Back Exhaust System
 Single Side Exit w/ 4" Slash Cut Tip
Chevy Silverado/GMC Sierra 2500HD Gas
2002-06 Crew Cab/Short Bed 6.0L - Part # 24296
2003-06 Ext. Cab/Short Bed 6.0L - Part # 24292

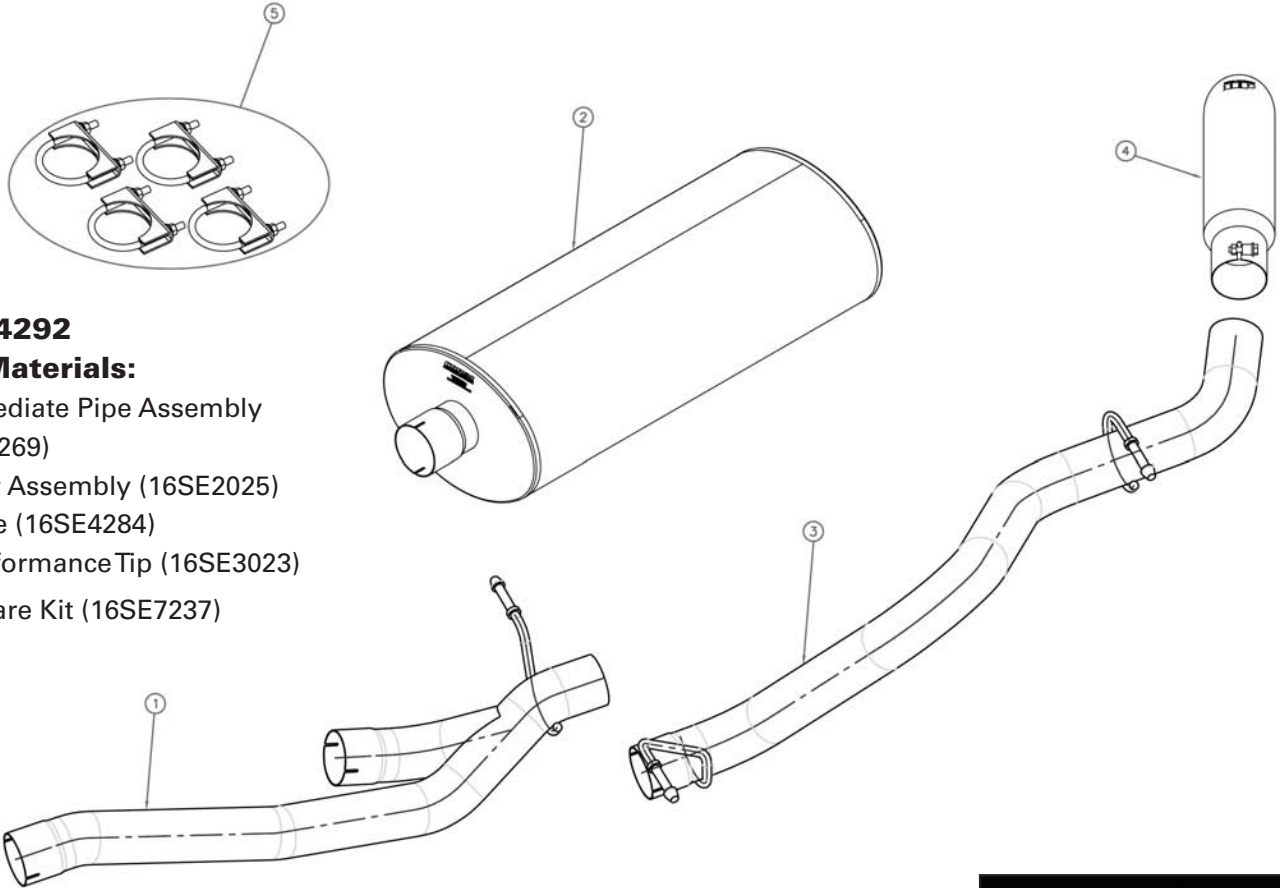

Part #24292

Bill of Materials:

- 1- Intermediate Pipe Assembly (16SE4269)
- 2- Muffler Assembly (16SE2025)
- 3- Tailpipe (16SE4284)
- 4- dB Performance Tip (16SE3023)
- 5- Hardware Kit (16SE7237)

Installation of dB Performance Exhaust System:

NOTE: The supplied double edge clamps in this system will crush and permanently deform the exhaust piping as they are tightened. **DO NOT** tighten these clamps any more than is necessary to lightly hold the exhaust components in place, until the very end of this installation process. It will be difficult or impossible to make any positional or rotational adjustments to the exhaust system after these clamps have been tightened down.

VERY IMPORTANT: Align all clamps so that the open edge of the clamp bracket is parallel and aligned with the notch in the pipe, and the outside edge of the clamp bracket is approximately 1/8" from the end of the pipe expansion. (See Fig. 1) Failure to properly position or orient the clamps could result in a weak clamping load, or even a potential leak at the clamp joints.

IMPORTANT: Make sure that the small drain holes in the muffler are facing down when the muffler is installed. (See Fig. 2)

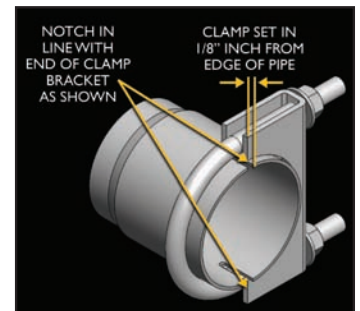

FIG. 1



FIG. 2



dB Performance Exhaust System Installation
Cat-Back Exhaust System
Single Side Exit w/ 4" Slash Cut Tip
Chevy Silverado/GMC Sierra 2500HD Gas
2002-06 Crew Cab/Short Bed 6.0L - Part # 24296
2003-06 Ext. Cab/Short Bed 6.0L - Part # 24292

IMPORTANT: Be sure to follow the correct instructions for your vehicle (i.e. EC/SB or CC/SB) and the correct instructions for the system purchased (i.e. single side exit or split dual side exit).

System Removal for Extended Cab/Short Bed (EC/SB): (See Page 2 for Crew Cab/Short Bed System Removal)

- 1) In order to remove factory exhaust system from vehicle and install your xhaust system, the pipe between the Catalytic Converter and Muffler must be cut. Measure 2-inches from the O2 Oxygen Sensor back towards the Muffler **(See Fig A1)**.

NOTE: Recheck your measurement and be sure to support muffler to prevent injury.

It is recommended that a chain-style pipe cutter be used to make the cut **(See Fig B1)**.

- 2) Next, remove the clamp from the other pipe entering the front of the Muffler **(See Fig C1)**.



FIG. A1

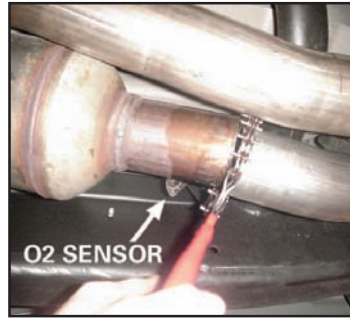

FIG. B1



FIG. D1



FIG. C1

- 3) Now remove the rubber grommet from the front Muffler hanger **(See Fig D1)**. Be sure to keep the rubber grommet as it will be needed for the installation.
- 4) Next, remove the rubber insulators from rear Muffler **(See Fig E below)** and Tail Pipe hangers **(See Fig F below)**.

Note: Using a soapy solution on the grommet hole will make the job easier.



FIG. E



FIG. F



FIG. G



dB Performance Exhaust System Installation
Cat-Back Exhaust System
Single Side Exit w/ 4" Slash Cut Tip
Chevy Silverado/GMC Sierra 2500HD Gas
2002-06 Crew Cab/Short Bed 6.0L - Part # 24296
2003-06 Ext. Cab/Short Bed 6.0L - Part # 24292

System Removal for Crew Cab/Short Bed (CC/SB):

- 1) Locate the Intermediate Pipe with a factory hanger and measure 2-1/2" back towards the muffler and mark pipe (**See Fig. A2**). Using a straight edge, mark another cut line on the adjacent Intermediate Pipe (**See Fig. B2**).

NOTE: Recheck your measurement and be sure to support muffler to prevent injury.

It is recommended that a chain-style pipe cutter be used to cut each Intermediate Pipe (**See Fig. C2**).

- 2) Now remove the rubber grommet from the front of the Muffler hanger (**See Fig. D2**). Be sure to keep the rubber grommet as it will be needed for the installation.
- 3) Next, remove the rubber grommet from rear Muffler (**See Fig. E on pg. 3**) and Tail Pipe hangers (**See Fig. F on pg. 3**).

Note: Using a soapy solution on the grommet hole will make the job easier.

Installation for Extended Cab/Short Bed (EC/SB):

- 1) Locate Intermediate Pipe and position Intermediate Pipe over factory outlet pipes (**See Fig I1**) . Slide supplied clamps over each inlet end (**See Fig H1**) and snug fit clamps (**See Figs. J & K**).
- 2) Insert Intermediate Pipe hanger in rubber grommet (**See Fig L**).



FIG. A2



FIG. B2



FIG. C2



FIG. D2



FIG. H1



FIG. I1



FIG. J



FIG. K



FIG. L

Continue to step 3
on page 5 >

**Installation for
 Extended Cab/Short Bed (EC/SB)
 CONTINUED:**

- 3) Next, locate Muffler and slide a supplied clamp over inlet end (**See Fig M**) and slide over Intermediate Pipe outlet (**See Fig N**) and snug fit clamp.



FIG. H2



FIG. I2

**Installation for
 Crew Cab/Short Bed (CC/SB):**

- 1) Locate Intermediate Pipe and position Intermediate Pipe over factory outlet pipes (**See Fig I2**). Slide supplied clamps over each inlet end (**See Fig H2**) and snug fit clamps (**See Figs. J & K**).
- 2) Insert Intermediate Pipe hanger in rubber grommet (**See Fig L**).
- 3) Next, locate Muffler and slide over Intermediate Pipe outlet (**See Fig M**). Slide a supplied clamp over inlet end (**See Fig N**) and snug fit clamp.
- 4) Locate Tail Pipe and route the inlet end over the axle housing, slide over Muffler outlet (**See Fig O**). Slide a supplied clamp over inlet end (**See Fig P**) and snug fit clamp. The Tail Pipe hanger can now be inserted into rubber grommet (**See Fig Q**).



FIG. J



FIG. K



FIG. L



FIG. M



FIG. N



FIG. O



FIG. P



FIG. Q



dB Performance Exhaust System Installation
Cat-Back Exhaust System
Single Side Exit w/ 4" Slash Cut Tip
Chevy Silverado/GMC Sierra 2500HD Gas
2002-06 Crew Cab/Short Bed 6.0L - Part # 24296
2003-06 Ext. Cab/Short Bed 6.0L - Part # 24292

- 5) Insert Tail Pipe rear hanger into rubber insulator (**See Fig R**).
- 6) Locate the dB Performance slash cut tip, which has a clamp built into it. Slide the clamp end of the tip onto the end of the tailpipe. (**See Fig. S**) Rotate the tip until the dB Performance logo is centered on the top side of the tip. Snugly tighten the clamp as shown using a 15mm socket and ratchet, making sure to only tighten the clamp enough to hold the tip in place on the tailpipe. (**See Fig. T & U**)
- 7) Visually inspect the exhaust system position, tip alignment, clamp orientation and position, and exhaust pipe clearance. Make any necessary adjustments at the slip joints.
- 8) Check for clearance from the front of the installed exhaust system to the Tail Pipe. Once clearance adjustments are made, start tightening each clamp beginning with the Intermediate Pipe clamp.
- 9) It is **STRONGLY SUGGESTED** that all clamps be checked and re-tightened (if necessary) to the recommended torque after initial road testing of the vehicle, as thermal cycling has occurred on the system. Please wait until system has fully cooled to conduct this process.



FIG. R



FIG. S



FIG. T



FIG. U