



dB Performance Exhaust System Installation
 Cat-Back Exhaust System
 Dual Rear Exit Exit w/ 4" Slash Cut Tips
Chevy Silverado/GMC Sierra 4.8L & 5.3L
 1999-06/7 RC/SB Part # 24274
 1999-06/7 RC/LB Part # 24275
 1999-06/7 EC/SB & CC Part # 24273

Please take time to read and understand these installation instructions.

We recommend that the installation of this system be performed by a qualified service center or professional muffler installer who has the necessary equipment, tools and experienced personnel. However, if you decide to perform this install, the use of a hoist and an additional person will be required.

CAUTION: Never work on a hot exhaust system. Allow time for the vehicle to cool. Always wear eye protection when working under a vehicle.

Please confirm that all parts are present before beginning the factory exhaust system removal and dB Performance Exhaust system installation.

Recommended Tools:

- Safety Glasses
- 15mm Wrench or Deep Socket
- 1/2-inch Socket
- Torque Wrench
- Soap & Water Solution

Bill of Materials:

- 1- Intermediate Pipe Assembly: Part# 24273 (16SE4206), Part# 24274 (16SE4239) OR Part# 24275 (16SE4226)
- 2- Muffler Assembly (16SE2022)
- 3- Dual "Y" Assembly (16SE4228)
- 4- Passenger Over-the-Axle Pipe (16SE4231)
- 5- Passenger Tailpipe Assembly (16SE4234)
- 6- Driver Over-the-Axle Pipe (16SE4233)
- 7- Driver Tailpipe Assembly (16SE4235)
- 8- dB Slash Cut Tip (16SE3024)
- 9- Hardware Kit (16SE7218)

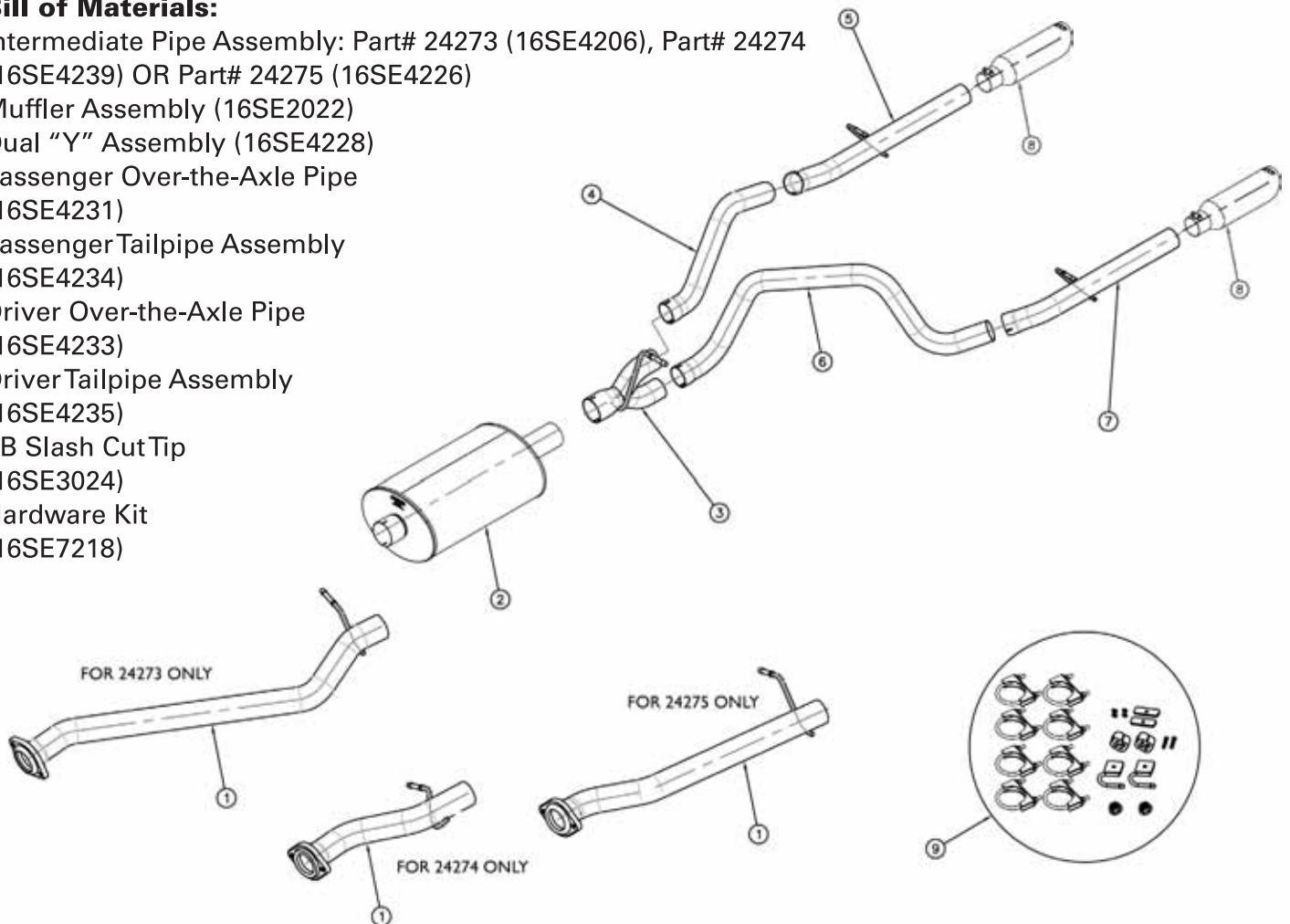

Stock Exhaust Removal Instructions

- 1) Unbolt intermediate-to-header pipe flange using 15mm deep socket (See Fig. A) and remove both bolts. Be sure to support muffler to prevent injury. Use lubricant to loosen bolts if necessary. Keep bolts as they will be needed for the final installation.
- 2) Next, remove hanger from rubber grommet located just in front of the muffler (near muffler inlet) (See Fig. B). It may be easier to first remove rubber grommet from frame hanger. Be sure to keep the rubber grommet. NOTE: Use lubricant on all hangers and rubber grommets to facilitate removal.
- 3) Remove Muffler Extension Pipe and tail pipe hangers from rubber grommets (See Fig. C). Be sure to keep the rubber grommets. Now entire system can be removed in one piece.

NOTE: Be sure to support muffler to prevent injury.



FIG. A



FIG. B



FIG. C

Installation of dB Performance Exhaust System:

NOTE: The supplied double edge clamps in this system will crush and permanently deform the exhaust piping as they are tightened. DO NOT tighten these clamps any more than is necessary to lightly hold the exhaust components in place, until the very end of this installation process. It will be difficult or impossible to make any positional or rotational adjustments to the exhaust system after these clamps have been tightened down.

VERY IMPORTANT: Align all clamps so that the open edge of the clamp bracket is parallel and aligned with the notch in the pipe, and the outside edge of the clamp bracket is approximately 1/8" from the end of the pipe expansion. (See Fig. 1) Failure to properly position or orient the clamps could result in a weak clamping load, or even a potential leak at the clamp joints.

IMPORTANT: Make sure that the small drain holes in the muffler are facing down when the muffler is installed. (See Fig. 2)

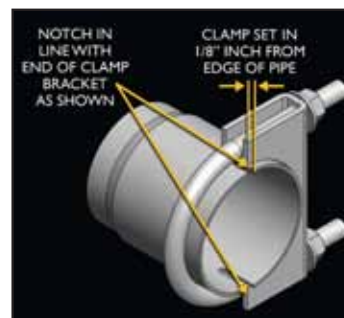
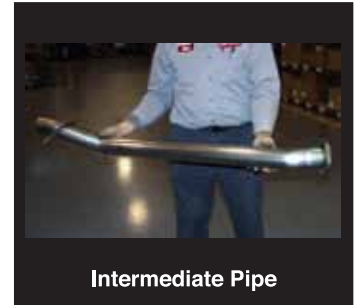

FIG. 1



FIG. 2

- 1) Locate Intermediate Pipe (**See Fig. D**) and position flange to header pipe flange. Insert bolts and hand tighten only (**See Fig. E**). Insert Intermediate Pipe hanger into rubber insulator (**See Fig. F**).
- 2) Slide slotted end of muffler onto Intermediate Pipe and slide a 3-inch clamp over the Muffler inlet. (**See Fig. G**) Snug-fit the clamp. Make sure Muffler weld seam is facing up (drain hole down). Do not tighten clamp at this time. NOTE: Be sure to support muffler to prevent injury.
- 3) Locate Y-Pipe (**See Fig. H**) and insert Y-Pipe hanger into rubber grommet (**See Fig. I**).
- 4) Slide expanded end over Muffler outlet (**See Fig. J**) and position a 3-inch clamp over expanded end of Y-Pipe. Snug fit the clamp. Do not tighten at this time.
- 5) Locate Rear tail pipe hangers ["U" shaped Wire Loop & Plate] and hardware [threaded Mounting Plate, bolts and lock washers] (**See Fig. K**). Starting on either side of the vehicle, position one of the threaded rectangular-shaped mounting plates on top of the frame rail over the hole located furthest forward from the rear of the frame (**See Fig. L & M passenger side shown**).



Intermediate Pipe

FIG.



FIG. E



FIG. F



FIG. G



FIG. H



FIG. I



FIG. J



FIG. K



FIG. L



FIG. M

- 6) Insert the supplied 5/16"-18 bolt through one of the tail pipe Wire Loop & Plate hangers and thread it into the threaded Mounting Plate on top of the frame. **NOTE:** Position **DRIVERS SIDE** hanger so that it faces towards the spare tire (**See Fig. N**) and the **PASSENGER SIDE** hanger so it faces out toward the passenger side of the vehicle (**See Fig. O**).

- 7) Locate **DRIVERS SIDE** Over-Axle Pipe (**See Fig. P**). Position pipe over the axle housing (**See Fig. Q**). Install pipe over the lower pipe on the muffler Y-Pipe (**See Fig. R**) and slide a 2-1/2-inch clamp over the expanded end of pipe. Snug fit the clamp, but do not tighten at this time.

- 8) Locate **DRIVERS SIDE** tail pipe (**See Fig. S**) [shorter of the two tail pipes] and install tail pipe onto Over-Axle Pipe (**See Fig. T**). Insert tail pipe hanger into provided rubber grommet (**See Fig. U**). Slide a 2-1/2-inch clamp over expanded end of pipe. Snug fit clamp, do not tighten at this time.



FIG. N



FIG. O



FIG. P



FIG. Q



FIG. R



FIG. S



FIG. T



FIG. U

- 9) Locate PASSENGER SIDE Over-Axle Pipe (**See Fig. V**). Position pipe over the axle housing and slide expanded end onto the upper pipe on the muffler Y-Pipe (**See Fig. W**). Slide a 2-1/2-inch clamp over expanded end of pipe. Snug fit the clamp, but do not tighten at this time.
- 10) Locate PASSENGER SIDE tail pipe (**See Fig. X**) and install tail pipe onto the Over-Axle Pipe (**See Fig. Y**). Insert tail pipe hanger into provided rubber grommet (**See Fig. Z**). Slide a 2-1/2-inch clamp over the expanded end of the pipe. Snug fit clamp, but do not tighten at this time.
- 11) Slide one of the tips over the outlet of the driver side tailpipe. With etched logo pointing up, loosely tighten the clamp at this time. (**See Fig. AA**). Repeat on passenger side.
- 12) Check alignment of tail pipes and Tips. Make sure that there is at least 1" clearance between the tips and the bottom of the bumper (**See Fig. BB**). Align tail pipes if necessary by making adjustments at the slip joints.
- 13) Starting with the Intermediate-to-Header Pipe, tighten the flange bolts, then tighten all clamps checking to make sure clamps are positioned and tightened. **Clamp Torque Setting: 16-20 ft.-lbs.**
- 14) It is strongly suggested that all clamps be checked and tightened if necessary after road testing the vehicle and after the system has cooled.



FIG. V



FIG. W



FIG. X



FIG. Y



FIG. Z



FIG. AA



FIG. BB

NOTE: During cold weather start-ups, you may experience an exhaust sound that is deeper and louder in tone than usual. This is temporary and will diminish to normal levels once your engine has reached its normal operating temperature. **NOTE:** Immediately following the installation of your exhaust system, you may experience a trace of smoke after initial start-up. **DO NOT** be alarmed. The smoke is caused by the burning of a small amount of forming oil residue used in the manufacturing process.