

**Please take time to read and understand these installation instructions.**

CORSA recommends that the installation of this system be performed by a qualified service center or professional muffler installer who has the necessary equipment, tools and experienced personnel. However, if you decide to perform this install, the use of a hoist and an additional person will be required.

**CAUTION:** Never work on a hot exhaust system. Allow time for the vehicle to cool. Always wear eye protection when working under a vehicle.

## **Recommended Tools:**

- 3/8" drive ratchet
- 3/8" drive 13mm socket
- 3/8" drive 15mm deep socket
- 10" 3/8" ratchet extension
- Grommet pullers
- Soap and water solution
- Torque Wrench
- Penetrating lubricant spray
- Safety glasses

**Please confirm that all parts are present according to the bill of materials before beginning the installation.**

### **Bill of Materials**

1. dB Tip Assembly – 16SE3023
2. Rear Muffler Assembly
  - a. 2.7L & 3.5L Ecoboost – 20FF2025
  - b. 5.0L NA V8 – 20FF2027
3. Tail Pipe Assembly – 20FF4145
4. Hardware Kit – 20FF7066

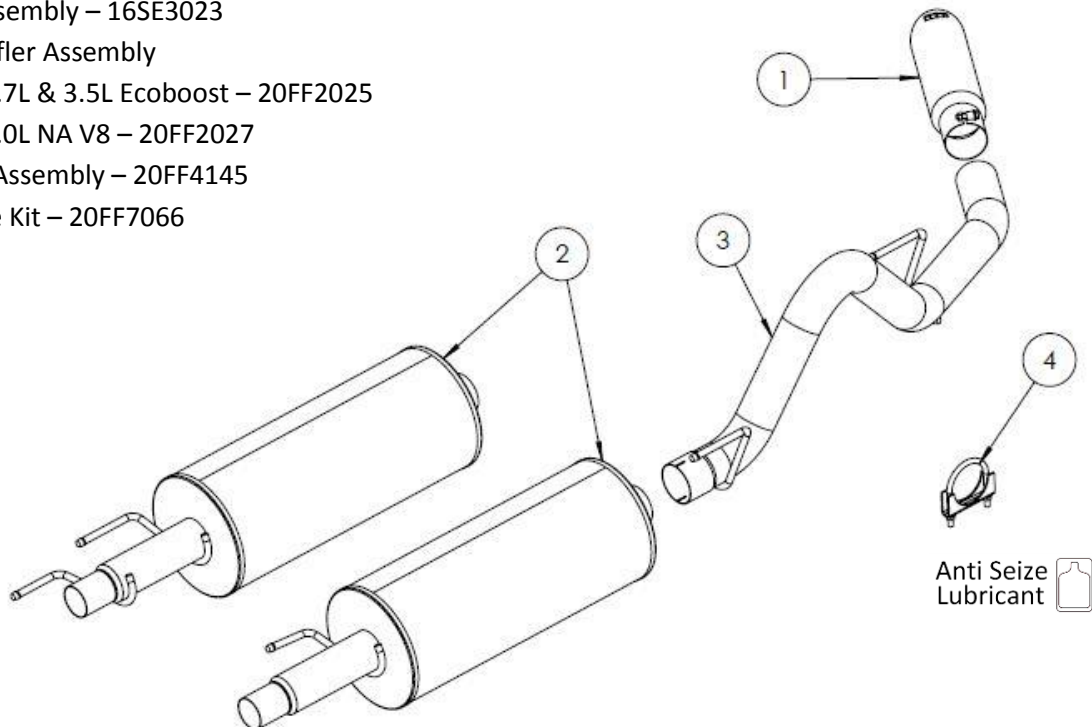

## **Factory Exhaust System Removal:**

1. Loosen the clamp connection located after the stock resonator using a 15mm deep socket and ratchet. The stock clamp is welded to the resonator assembly and cannot be removed or rotated. **(Fig A)**
2. Loosen the two 13mm bolts at the resonator flange connection. Do not completely remove these bolts. **(Fig B)** Place a jack stand or similar device under the outlet end of the resonator for support.
3. Rotate the stock resonator clockwise until the retaining boss on the stock cat-back exhaust is aligned with the slot on the resonator. **(Fig C)**
4. For the 5.0L engine only - Use the grommet pullers to remove only the front muffler hanger from its grommet. **(Fig D)**

**Note:** The use of a soapy water solution may aid in the removal of hangers.

5. Slide the entire stock system rearward to free all remaining hangers from their grommets. Also, make sure that the front muffler pipe cleanly separates from the resonator pipe. Use caution at this step as the weight of the exhaust system will no longer be supported by the grommets. **(Fig E, F, & G)**

**Note:** The use of a soapy water solution may aid in the removal of hangers.

6. Once all hangers are removed from their grommets, remove the entire system from the vehicle by lowering it down as you slide it forward and allowing the tailpipe to travel over the rear axle. **(Fig H)**
7. The stock exhaust should now be clear of the vehicle. **(Fig I for the 5.0L)(Fig J for the 2.7L/3.5L)**

**REMOVAL PICTURES ON NEXT PAGE** 

**Factory Exhaust Removal Pictures**



Fig. A



Fig. B



Fig. C



Fig. D



Fig. E

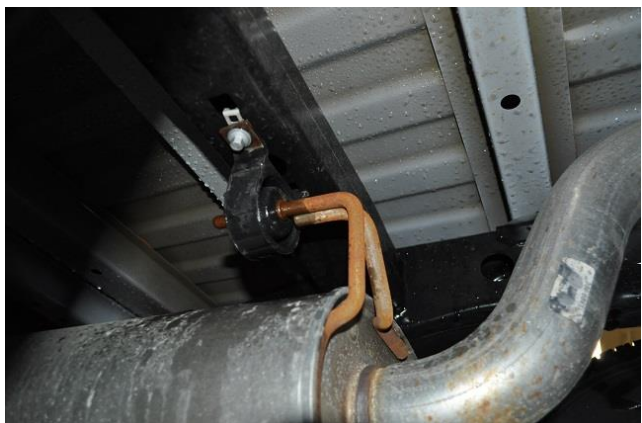

Fig. F

CONTINUED ON NEXT PAGE 

**Factory Exhaust Removal Pictures**



Fig. G



Fig. H



Fig. I

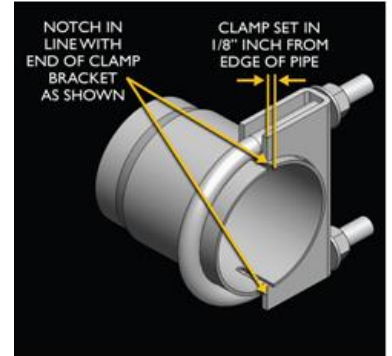

Fig. J

## Installation of dB by CORSA Exhaust System:

**NOTE:** The supplied double edge clamps in this system will crush and permanently deform the exhaust piping as they are tightened. DO NOT tighten these clamps any more than is necessary to lightly hold the exhaust components in place, until the very end of this installation process. It will be difficult or impossible to make any positional or rotational adjustments to the exhaust system after these clamps have been tightened down.

**VERY IMPORTANT:** Align all clamps so that the open edge of the clamp bracket is parallel and aligned with the notch in the pipe, and the outside edge of the clamp bracket is approximately 1/8" from the end of the pipe expansion. (See Fig. CLAMP) Failure to properly position or orient the clamps could result in a weak clamping load, or even a potential leak at the clamp joints.



1. Remove all exhaust components from the shipping carton, including the supplied 3" clamp.
2. Locate the dB by CORSA Performance muffler and align the inlet to the stock resonator outlet along with the front muffler hangers to their corresponding grommets. Insert the muffler inlet into the resonator outlet along with the rear hangers. **(5.0L - Fig K) (2.7L & 3.5L Fig L)**
- Note:** The use of a soap and water solution may aid in the installation of the hanger grommets.
3. Rotate the stock resonator so that the drain hole, located on rear endcap, is towards the ground. Once the drain hole is in proper position, snug the factory clamp connection using a 15mm socket and ratchet. **(Fig M)**
4. Locate the U-clamp and install it over the expanded end of the tailpipe. **(Fig N)** Slide the tailpipe over the rear axle and position the tailpipe hangers in-line with their corresponding hanger grommet assemblies. Once the tailpipe is positioned slide the tailpipe assembly forward to install the hangers. **(Fig O & P)**

**Note:** Removing the rear tailpipe grommet assembly from the vehicle and installing it on the rear tailpipe hanger beforehand may simplify the installation, but is not required if the tailpipe is positioned correctly.

5. Insert the muffler outlet pipe into tailpipe inlet, properly position the clamp and snug it using a 14mm deep socket and ratchet. **(Fig Q & R)**
6. Locate the tip assembly. Properly align the tip onto the tailpipe outlet. **(Fig S)** Snug the bolt located on the top of the tip assembly using a 13mm socket and ratchet. **(Fig T)**

CONTINUED ON NEXT PAGE





**Cat Back Exhaust System  
Single Side Exit w/ 4.0" Tip  
2015+ Ford F150  
PN 24836, 24837**

7. Check the alignment of tip assembly to the rear quarter panel. Ideally, the etched dB by CORSA logo should be at the very top of the tip. Adjust tip rotation and overlap as necessary. **(Fig U & V)**
8. Visually inspect the exhaust system position, tip alignment, clamp orientation and position, and exhaust pipe clearance. Make any necessary adjustments at the slip joints.
9. Fully tighten the 13mm bolts at the flange connection and torque to factory specs. Next, tighten the factory clamp at the resonator/muffler connection to 45 ft-lbs.
10. Starting at the front of the vehicle, tighten the nuts on the supplied clamp. Torque the nuts to 35 ft-lbs. Torque the bolt on the tip assembly to 16-20 ft-lbs.
11. It is **STRONGLY SUGGESTED** that all clamps be checked and re-tightened (if necessary) to the recommended torque after initial road testing of the vehicle, as thermal cycling has occurred on the system. Please wait until the system has fully cooled to perform this step.

**NOTE:** During cold weather start-ups, you may experience an exhaust sound that is deeper and louder in tone than usual. This is temporary and will diminish to normal levels once your engine has reached its normal operating temperature.

**NOTE:** Immediately following the installation of your exhaust system, you may experience a trace of smoke after initial start-up. **DO NOT** be alarmed. The smoke is caused by the burning of a small amount of forming oil residue used in the manufacturing process.

**INSTALLATION PICTURES ON NEXT PAGE** 

**dB by CORSA Exhaust Installation Pictures**



Fig. K

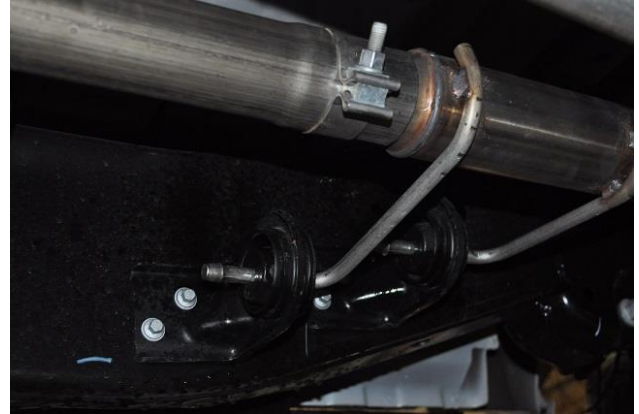

Fig. L

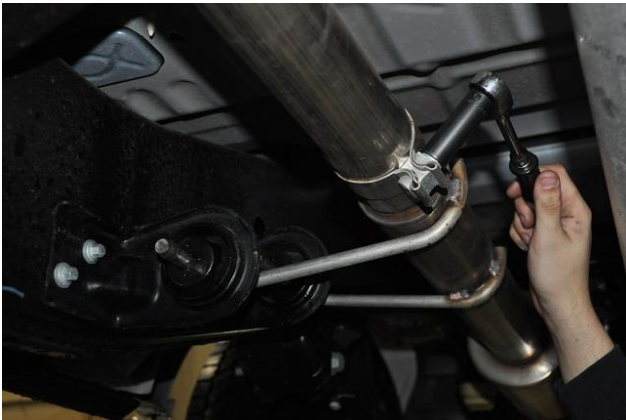

Fig. M



Fig.

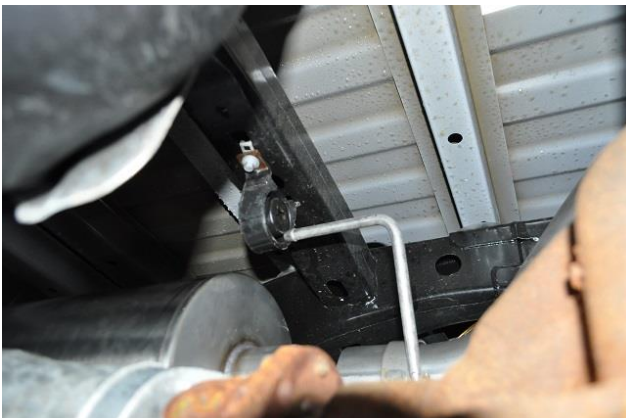

Fig. O



Fig. P

CONTINUED ON NEXT PAGE 

**dB by CORSA Exhaust Installation Pictures:**

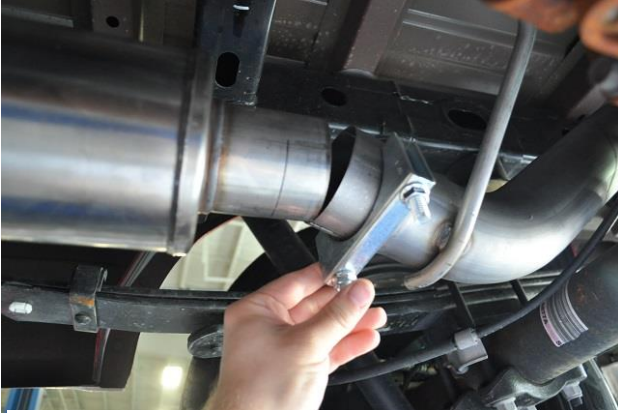

Fig. Q



Fig. R



Fig. S



Fig. T



Fig. U



Fig. V