



DARTON SLEEVES

**LS2 Dry Sleeve Kit
Installation Guide**



Thank you for purchasing the Darton state of the art new **GM™ LS-2 Dry Sleeve Kit**. The kit makes possible maximum bore sizes, increased cylinder strength and superior wear resistance.

Darton wants to provide you with the best technical information we have available to ensure that your sleeved engine will perform to your expectations. Therefore, we have formulated a program of required procedures and components, which we believe will ensure operating success of your sleeved engine in whatever application it will see service in.

INSTALLATION PROCEDURES

Revised 5-15-06

LS2 Dry Sleeve Kit Installation

Read and make sure you understand these instruction before proceeding with block machining. If you have questions concerning machining, assembly, proper tooling, machines, etc.

Preparation, Fixturing:

1. The block needs to be fully stripped, cleaned and inspected before machining. Main web cracks, or structural damage will prevent satisfactory sleeve installation.
2. Brand new blocks must be vibratory stress relieved prior to block machining. Failure to do this will result in out of round cylinder bores after the engine is fired up.

Setup and Block Machining:

1. With your block mounting fixture securely bolted to the CNC machine table, indicate the centerline of your block mounting bar in the "Y" axis direction. That will be your "Y" fixture or part offset depending on terminology used with your machine. You will only have to do this one time since this position will remain the same. The object is to correct for factory machining errors, block warpage. You want the dry liners installed directly over the crankshaft axis and not offset as would probably happen if you merely went off the existing cylinder centerline.

Now set the block up on the CNC machine. The preferred method is with precision made mounting rings located in the front and rear main bearing bores and with the bell housing face securely bolted to a fixture plate. Rotate your fixture so the left (driver's side bank) is facing up. Indicate the rear deck surface of the block (by the bell housing) - **photo 1**. Rotate the block around the crank axis until you get close to zero run out across the deck from side to side. Lock your fixture when you are satisfied the block is true. Zero the degree wheel if so equipped. Note that most blocks will be warped front to back. This is why I recommend dialing in the deck surface at the rear of the block. Now indicate the "X" centerline of cylinder number one, (left bank first cylinder) - **photo 2**. The centerline position is your "X" fixture offset position. Enter the "X" and "Y" offsets in your machine's fixture or part offset table.

2. Clean the rust preventative from the sleeves using lacquer thinner. Measure the bottom diameter of each sleeve. Generally the diameters will be very close - within .001" in any one set. Measure the diameters at 90 degrees and average the result - **photo 3**. The lower sleeve diam-

eter specification is 4.275". The block is bored .0015" to .0017" **larger** than the sleeve lower diameter. Do not attempt to install the sleeves if you can not hold this tolerance. The upper body diameter has a slight taper. Measure the diameter directly under the flange. This diameter specification is 4.325". Again, the block will be bored .0015" to .0017" **larger** than your measured diameter.

3. Touch off your tools on the deck surface at the front of the left bank either before you begin machining or as you are about to use them, whichever you prefer - **photo 4**. Set your tool length offsets into your machine's tool table. Machining depths are from the deck surface down.
4. Note that the bore center to center is 4.400", same as a small block Chevy. You need to keep this centerline dimension to $\pm .0005$ ". Note that in order to maintain the required tolerances it is highly advisable you use a machine with flood coolant. It will be impossible to hold tolerance otherwise and a poor job will be the result.
5. First operation is to bore the four cylinders on the left bank to 4.170" diameter to the main bearing webs. Use a double cutter boring head with .030" radius inserts for this operation which will allow sizing in one pass - **photos 5 and 6**. Depth of cut is 6.250" from the deck surface.
6. Next operation is boring for the lower body diameter. Bore larger than sleeve as instructed above. Depth of bore should be 5.850" to clean up the casting at the bottom of the bore. **Photos 7 and 8**.
7. Next operation is boring for the upper body diameter. Again, bore larger than the measured sleeve diameter as instructed above. Machining depth should be 3.280" to 3.300". **Photo 9**.
8. Next, machine the upper flange diameter to your measured diameter $+ .002$ ". The nominal diameter on the sleeve flange is 4.550". Your flange bore should be 4.552" machined to a depth of .202". You can bore or use circular interpolation for this cut dependent on your tooling and expertise. If you use circular interpolation with a carbide end mill, use two passes leaving $\sim .010$ " for the finish pass. **Photo 10**. This will ensure in a better surface finish and rounder hole.
9. Repeat operations (5 through 8) on the opposite bank after indexing the block 90 degrees. Note that the offset for cylinder two (front cylinder on the right bank) is $+ .950$ " towards the rear of the block from cylinder one on the left bank. Make certain to adjust your new "X" offset in the machine fixture or part offset table else you will ruin your block. **Photo 11**.
10. Prior to removing the block from the machine, run a ball hone through all the bores. Remove the block, clean it, and deburr it. Make certain the head threads are clean. A thread forming tool should be run through the head bolt holes on used blocks. **Photo 12**.

NOTES:

Sleeve Installation:

1. It is not necessary but recommended to heat the block to no more than 80° for sleeve installation. Leaving the block sit in the sun for a few minutes is sufficient. If the machining was done properly cooled sleeves will easily install with a shot filled plastic mallet and drive home with an aluminum plate and hammer.
2. Apply a very thin coat of Loctite 515 or 518 flange sealer to the lower bore as shown. And to each upper bore as shown. **Photo 13.**
3. Chill sleeves in refrigerator or freezer. Drop them into the block two at a time making certain the sleeve flats are aligned. Do not drive the sleeves into place until all four are installed and aligned. The sleeves should go into the bore 3/4 or more of the way with very slight hand pressure. **Photo 14.**
4. Carefully drive sleeves into place using plastic mallet then aluminum plate with heavier steel or brass hammer. Drive a bit at a time so the flats remain in alignment with one another. Installed sleeves should look like **photo 15.**
5. Now install deck plates with Fel Pro 1041 or other composition style gasket. Torque ARP bolts to fifty ft./lbs. Let sit for at least 4-24 hours so the Loctite sets up; or you can use Loctite Primer #1649 or acetone for a 30 min to 4 hour set-up. Remove plates, deck flat, then finish bore and hone block. Sleeves are designed for finished bores between 4.125" to 4.155". **Photo 16.**

Main cap studs and align honing are highly recommended.

BLOCK SPEC LS-2 DRY SLEEVE

NOTE:

1. BORE THRU TO MAIN WEB AT FINISH
BORE DIA +.010

REVISIONS			
REV	DESCRIPTION	DATE	APPROVAL
A	"C" DIM 5.850±.020 WAS 5.750±.020	03/01/06	

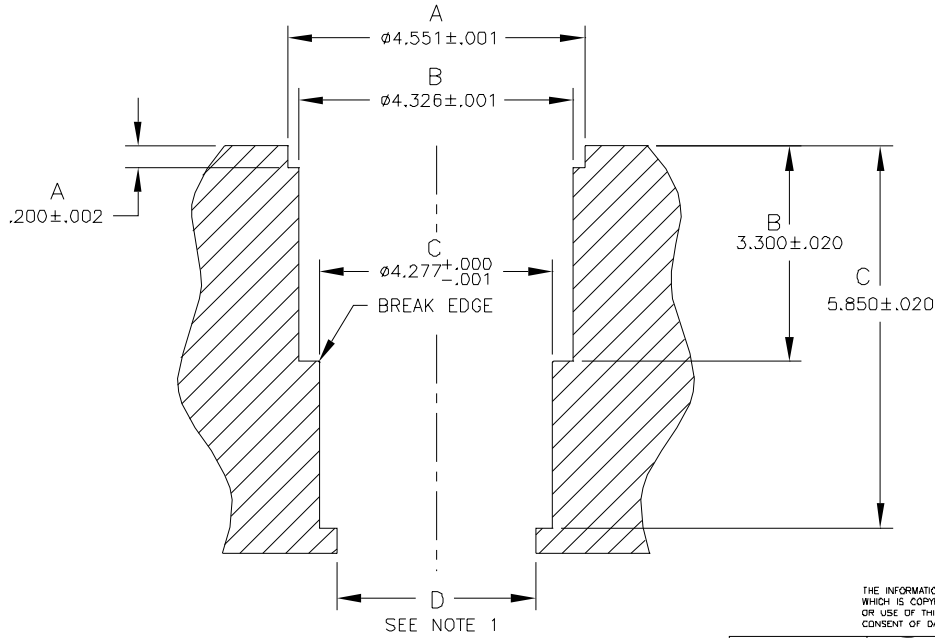

THE INFORMATION DEPICTED HEREIN IS PROPRIETARY DESIGN INFORMATION WHICH IS COPYRIGHTED BY DARTON INTERNATIONAL, INC. NO DUPLICATION OR USE OF THIS INFORMATION IS PERMITTED WITHOUT EXPRESS WRITTEN CONSENT OF DARTON INTERNATIONAL, INC.

DR. BY:	CAD DEPT	 Darton International, Inc. Carlsbad, CA USA (800) 713-2766 (760) 863-9895 FAX (760) 863-9629 WWW.DARTON-INTERNATIONAL.COM		
DATE:	11/18/05			
CHK'D BY:		TITLE		
MATERIAL:		LS-2 DRY SLEEVE		
HARDNESS:		SIZE	DWG NO.	REV
		A	4.125-BORE	A
		SCALE	SHEET 1 OF 1	
		NONE		

© DARTON INT. INC.

File No. F:\ACAD_DAT\ Darton\CUSTOMER\LS-2\4.125-BORE

NOTES:

NOTES:

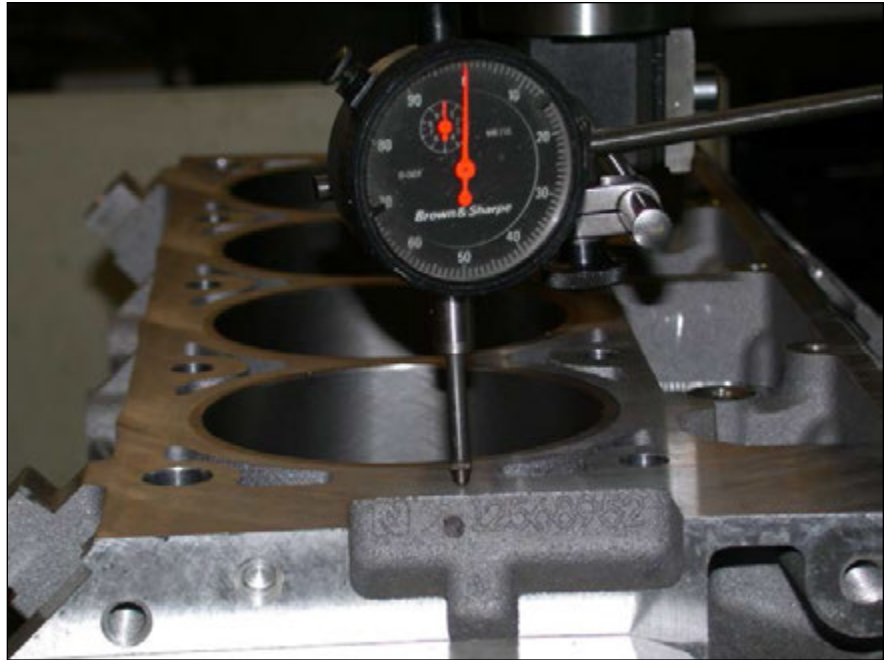

PHOTO 1

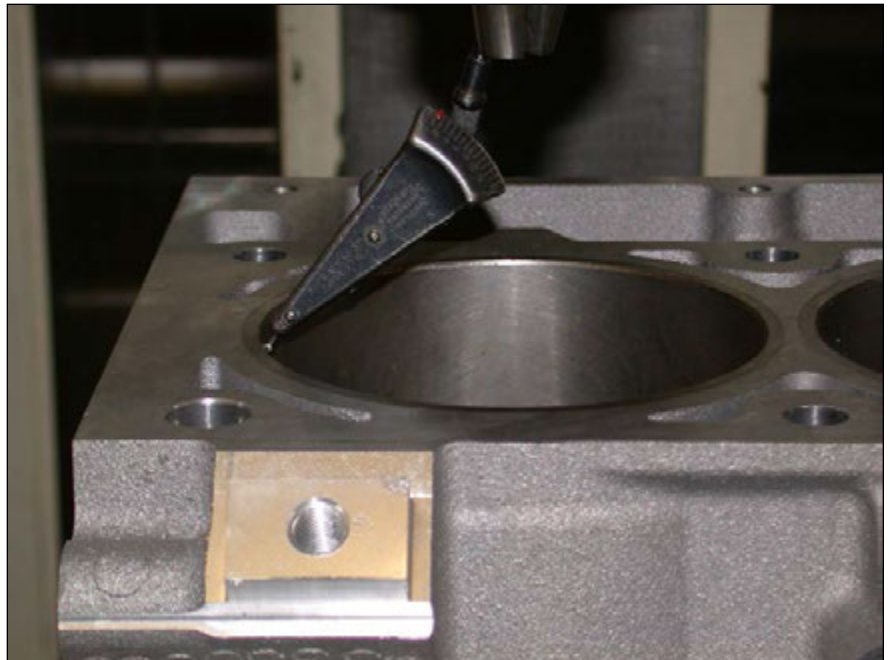

PHOTO 2

NOTES:



PHOTO 3

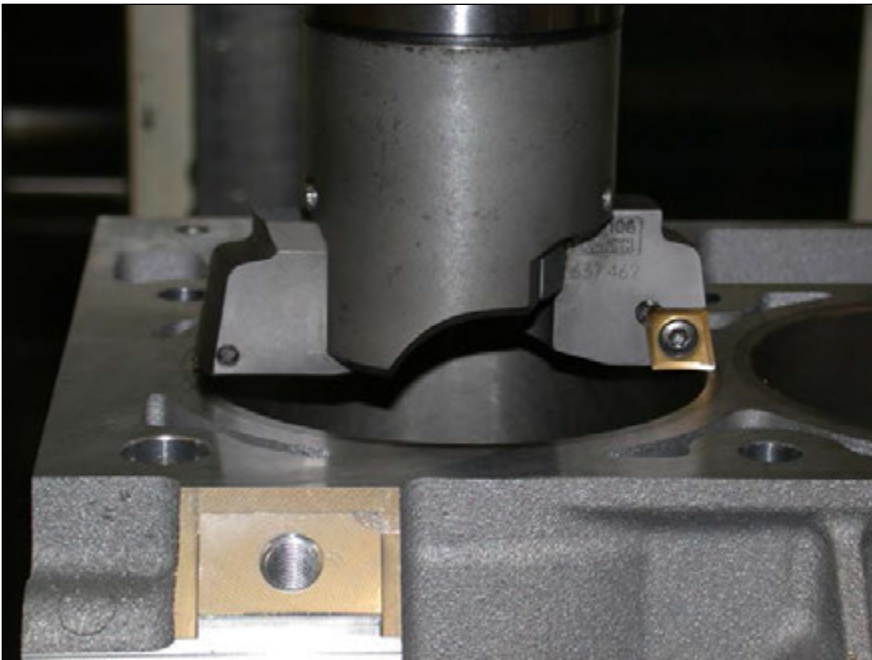

PHOTO 4

NOTES:



PHOTO 5



PHOTO 6

NOTES:

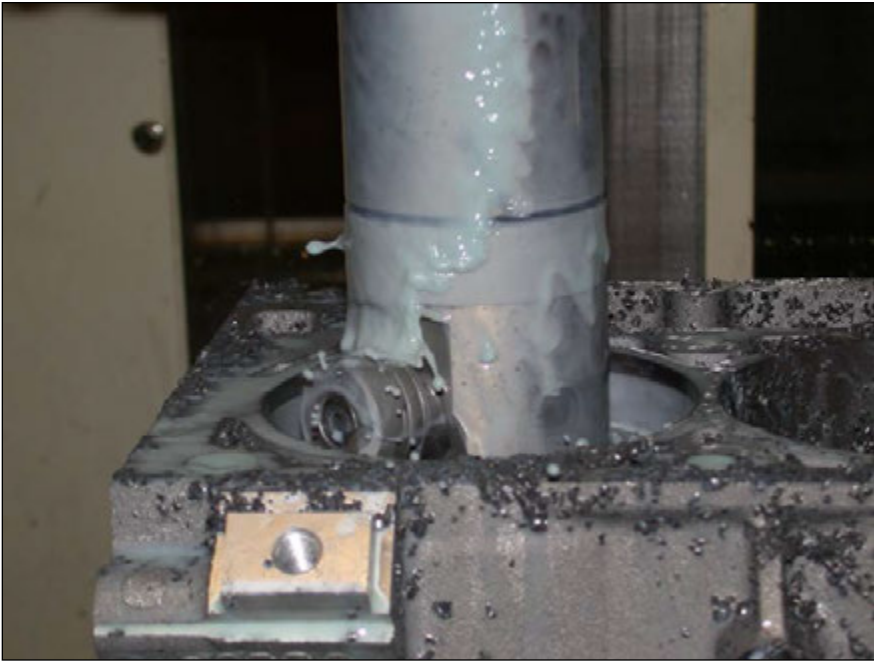

PHOTO 7



PHOTO 8

NOTES:



PHOTO 9



PHOTO 10

NOTES:



PHOTO 11

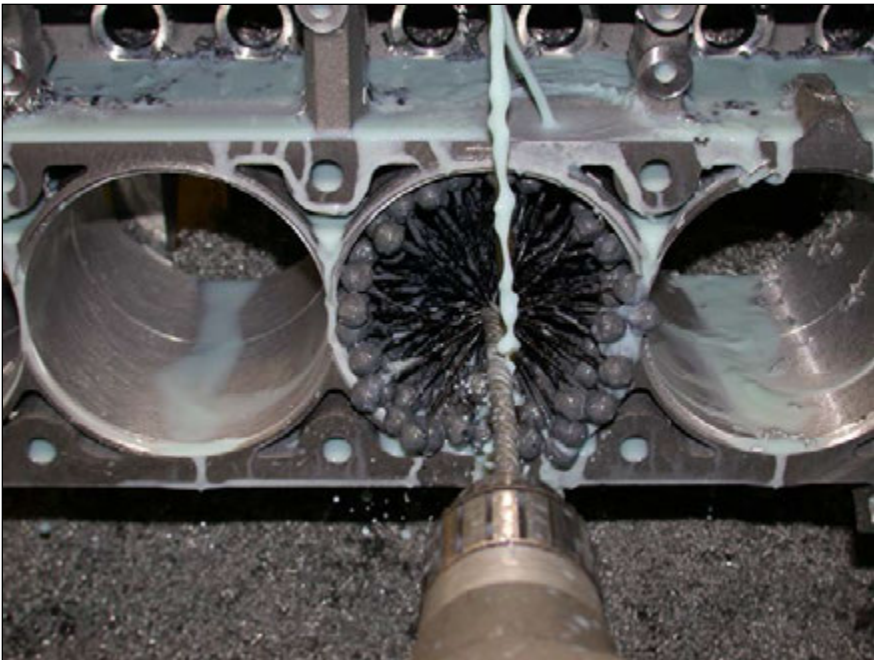

PHOTO 12

NOTES:



PHOTO 13

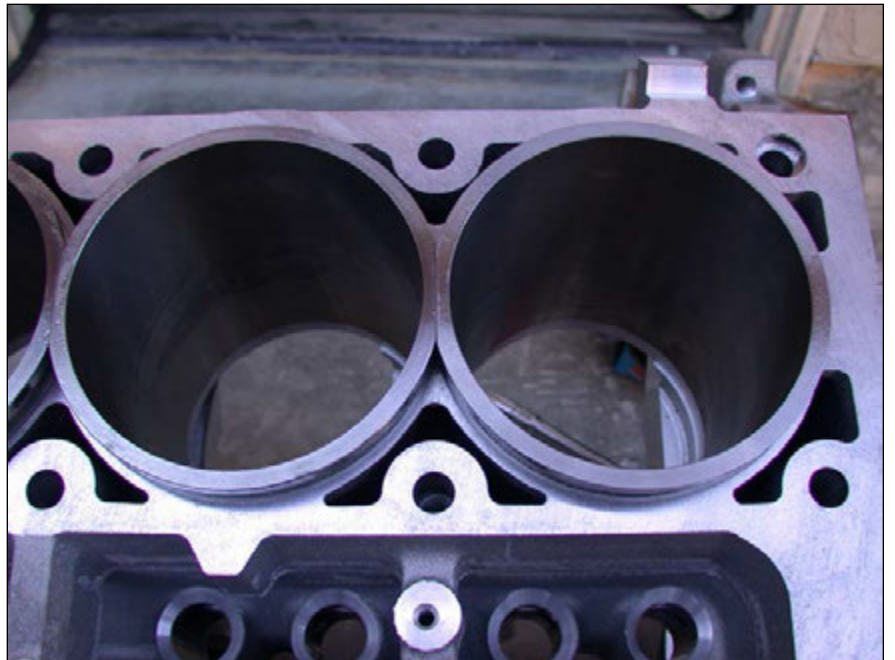

PHOTO 14

NOTES:



PHOTO 15



PHOTO 16



**Not actual gasket shown.*

FOR BEST RESULTS:

Darton recommends the use of a Cometic M.I.D. MLS head gasket. These head gaskets are specifically made for use with our M.I.D. kits and work with our LS-2 Dry Sleeve Kit.

NOTES/CAUTIONS:

1. Make sure that block and head surfaces are machined within proper RMS specification.
2. Depending on the type of head bolts used, a re-torque of head bolts to proper specifications may be required.

EVANS PRODUCTS

Darton recommends the use of **Evans** coolant!



MPG+ for all street applications.

MPGR for full race applications.

T
N
E
M
P
I
Q
U
E
G
I
N
D
I
L
I
U
B
E
R
E
N
G
I
N
E
N
G
I
O
N
I
S
I
O
N
P
R
E
C
I
S
I
O
N

Sunnen CV-616 Setup



The cost-effective Sunnen CV-616 Automatic Cylinder Hone is one of the most versatile machines you can have in your shop. You can count on consistent results as the CV-616 produces the most precise cylinder bores possible, cylinder after cylinder, block after block.

Results with Sunnen Honing Stones on Darton Cylinder Sleeve Material

	EHU 412
RA	23.14 μ "
RY	231.14 μ "
RZ	184.4 μ "
RPK	26.34 μ "
RVK	68.14 μ "
RK	80.14 μ "
MR1	7%
MR2	86%

	EHU 518
RA	25.1 μ "
RY	266.2 μ "
RZ	198.3 μ "
RPK	29.9 μ "
RVK	44.5 μ "
RK	89.7 μ "
MR1	6%
MR2	88%

	EHU-412
C30 PHT	731 - 45 Seconds
RA	15.4 μ "
RY	162.4 μ "
RZ	127.4 μ "
RPK	10.5 μ "
RVK	40.9 μ "
RK	35.4 μ "
MR1	5%
MR2	88%

	EHU 518
C30 PHT	731 - 30 Seconds
RA	9.0 μ "
RY	132.0 μ "
RZ	93.5 μ "
RPK	7.8 μ "
RVK	38.4 μ "
RK	23.8 μ "
MR1	5%
MR2	81%



Sunnen CV-616 Set-up

JHU 623

RA	10 μ "
RY	99.6 μ "
RZ	85.5 μ "
RPK	17.8 μ "
RVK	18.8 μ "
RK	34.7 μ "
MR1	10%
MR2	89%

JHU 623

C30 PHT 731 - 15 Seconds

RA	6.4 μ "
RY	79.7 μ "
RZ	62.3 μ "
RPK	4.8 μ "
RVK	13.3 μ "
RK	20.9 μ "
MR1	4%
MR2	89%

Results obtained with Sunnen
MAN 845 honing oils. Results
may vary with other oils.

