





- Installation Manual -

965 488 A

[Rear Differential Carrier Brace](#)

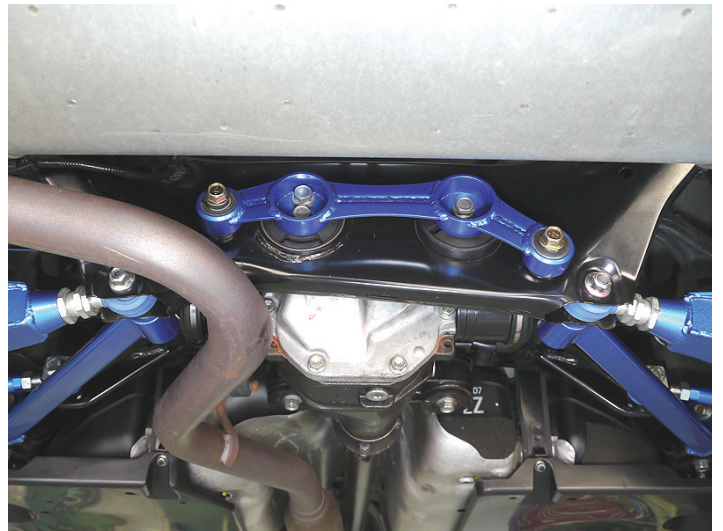
[Part Number]	965 488 A
[Application]	Toyota 86 / Scion FR-S [ZN6] Subaru BRZ [ZC6]
[Product]	Powerbrace Rear Differential
[Description]	Rear Differential Carrier Brace
[Contents]	Brace x1 32mm Spacer x2 M12 x 55 Bolt x1 M12 x 65 Bolt x1 M12 Nut x2 M12 Flat Washer x2



 **NOTE** Always use a proper vehicle lift when installing Cusco products. Always follow OSHA safety standards when working on or under a vehicle.

This installation manual serves as a general guideline for Cusco product install. Please refer to the factory service manual for the proper procedures for installation.

[Procedure]

1.) Remove the left side lateral link nuts and bolts.

*Pictured below is Cusco product #692 474 L. Same installation procedure applies to factory arms.

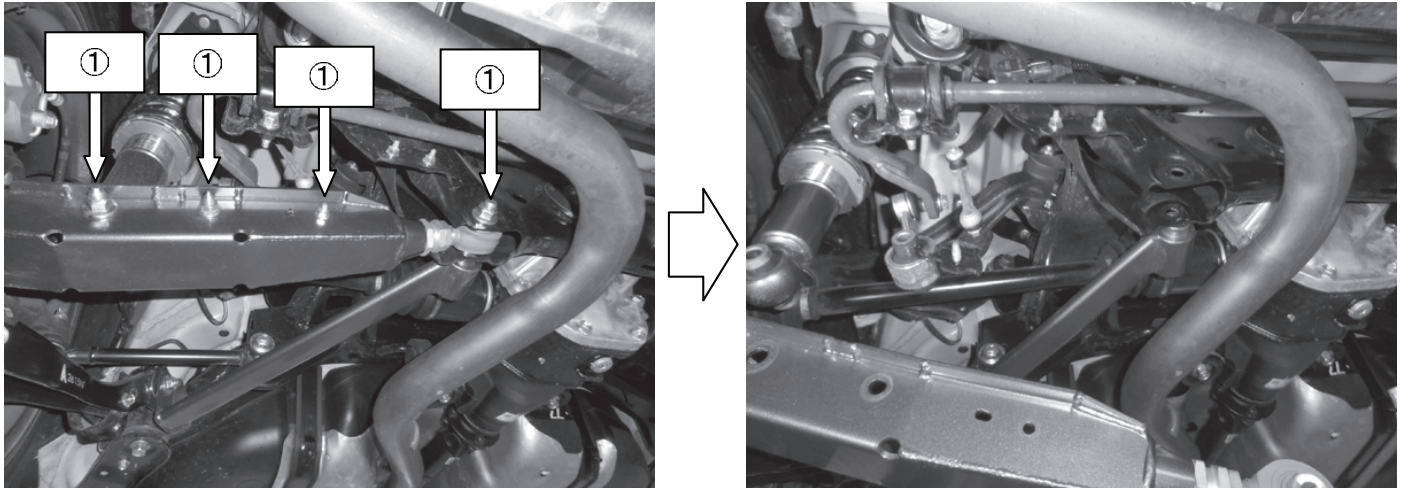

2.) Secure the rear differential carrier with a transmission jack and remove the three bolts indicated below.

NOTE Make sure that the rear differential carrier will not fall and the transmission jack is holding the unit securely.

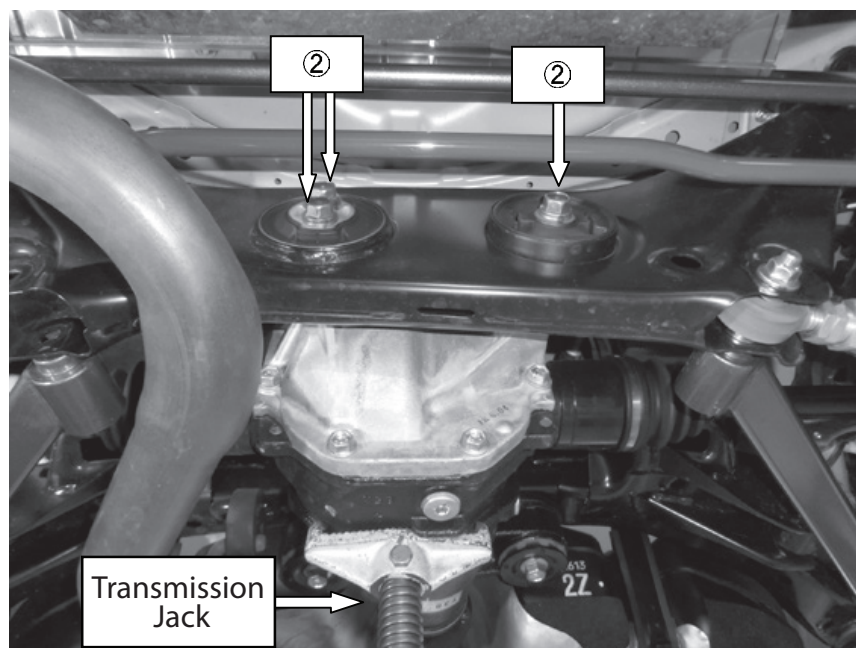

Rear Differential Carrier Brace

3.) Install the Rear Differential Carrier Brace with the included 32mm Spacer, M12 x 55 Bolt, M12 x 65 Bolt and M12 Nut. Do not tighten yet.

Left Side

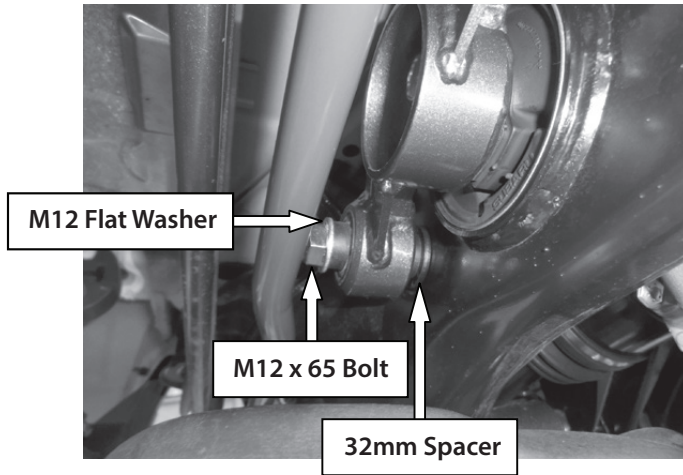

Right Side

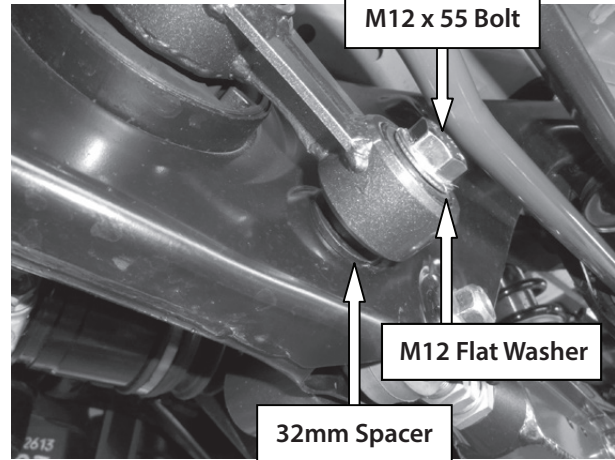

Left Side

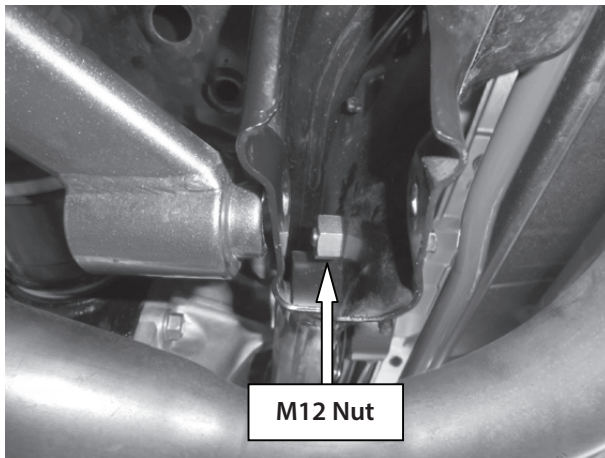

*The M12 Nut is mounted inside the rear member frame.

4.) Once everything is in place, torque down the hardware according to factory service manual specifications.

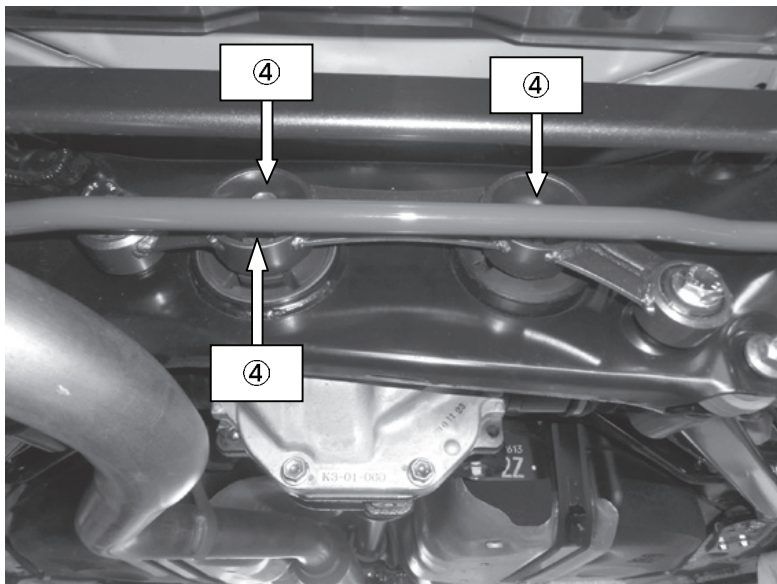

5.) Reinstall rear lateral link.

**Periodically check and re-torque all nuts and bolts after operating vehicle.