



- Installation Manual -

666 311 BJ22

[Stabilizer / Anti-Sway Bar](#)

[Part Number]	666 311 BJ22
[Application]	Subaru Impreza [GDA] Subaru Impreza STi [GDB] Subaru Impreza Wagon GGA
[Product]	Stabilizer / Anti-Sway Bar
[Description]	Rear Adjustable 22mm Sway Bar
[Contents]	Sway Bar x1 Bushing x2 Installation Manual x1

NOTE

Always use a proper vehicle lift when installing Cusco Sway Bars. Always follow OSHA safety standards when working on or under a vehicle.

This installation manual serves as a general guideline for Cusco product install. Please refer to the factory service manual for the proper procedure for engine and transmission mount install.

[Procedure] See the photo diagram below in reference to the numbers

- 1.) Remove sway bar links.
 - 2.) Remove sway bar mounts.
 - 3.) Remove sway bar unit.
 - 4.) Installation is performed in reverse order of removal. Do not re-use the factory bushings, please use the included Cusco bushings.
- *Please refer to the manufacturer factory service manual for torque specifications.

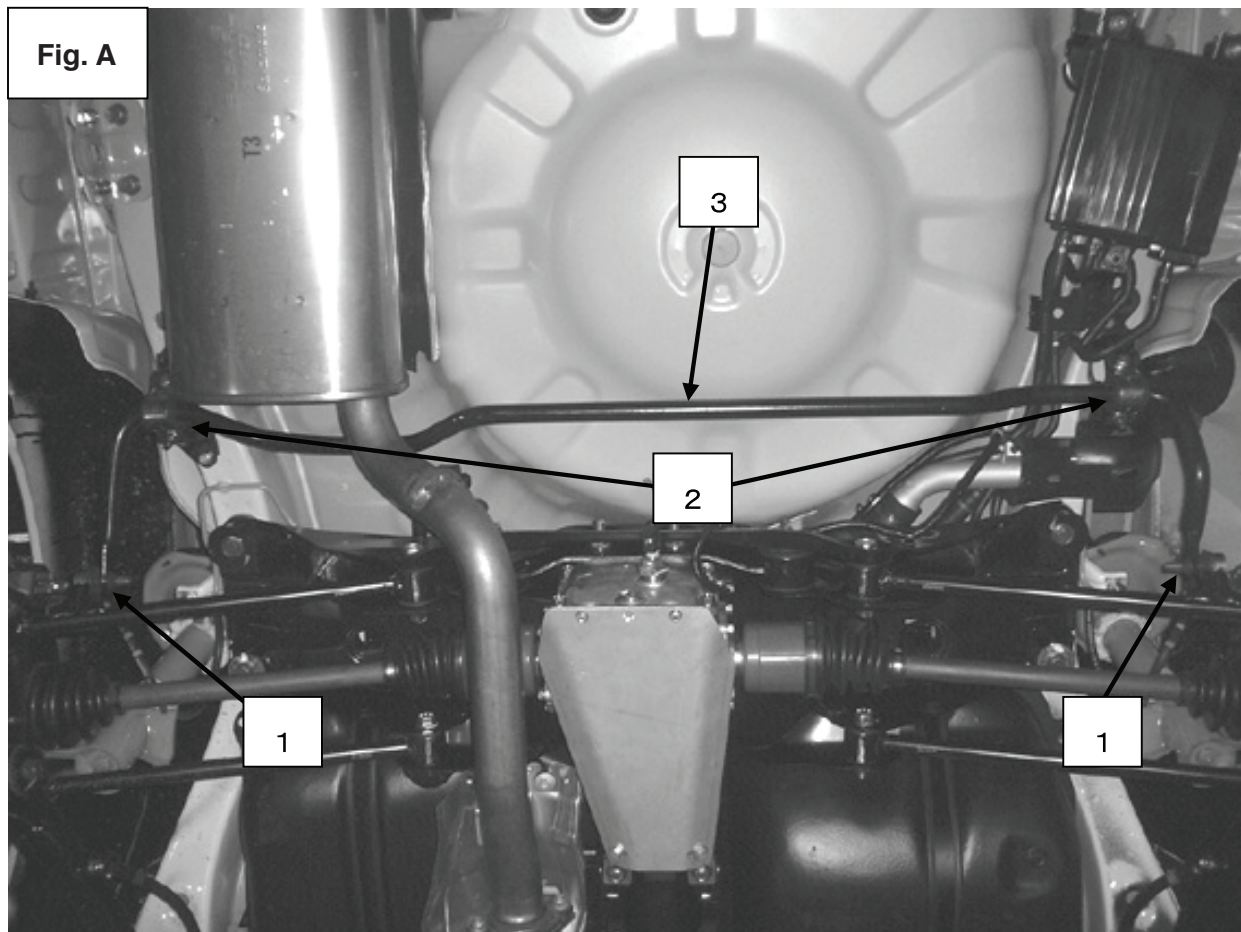

Setting sway bar effectiveness over stock

- This sway bar unit is 3 way adjustable.
- Installing the link in hole "C" will stiffen the sway effect.
- Effectiveness in reference over factory sway bar:
A=135% B=158% C=173%

Fig. B

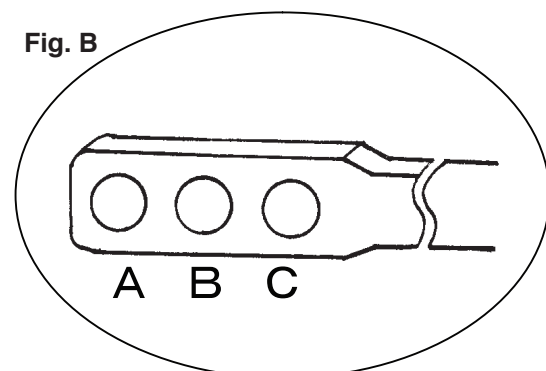



Warning

Use caution when using the stiffest sway bar setting which is hole 'C' (Fig. C) When lowering the vehicle, there is a possibility where the end link will bind to the rear and downward position. On Fig. D, the #1 position is when the vehicle is raised, and should be in the #2 position when vehicle is lowered. Watch sway bar link angle when lowering vehicle!

Fig. C

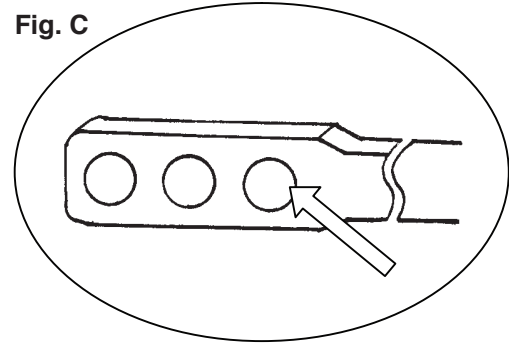
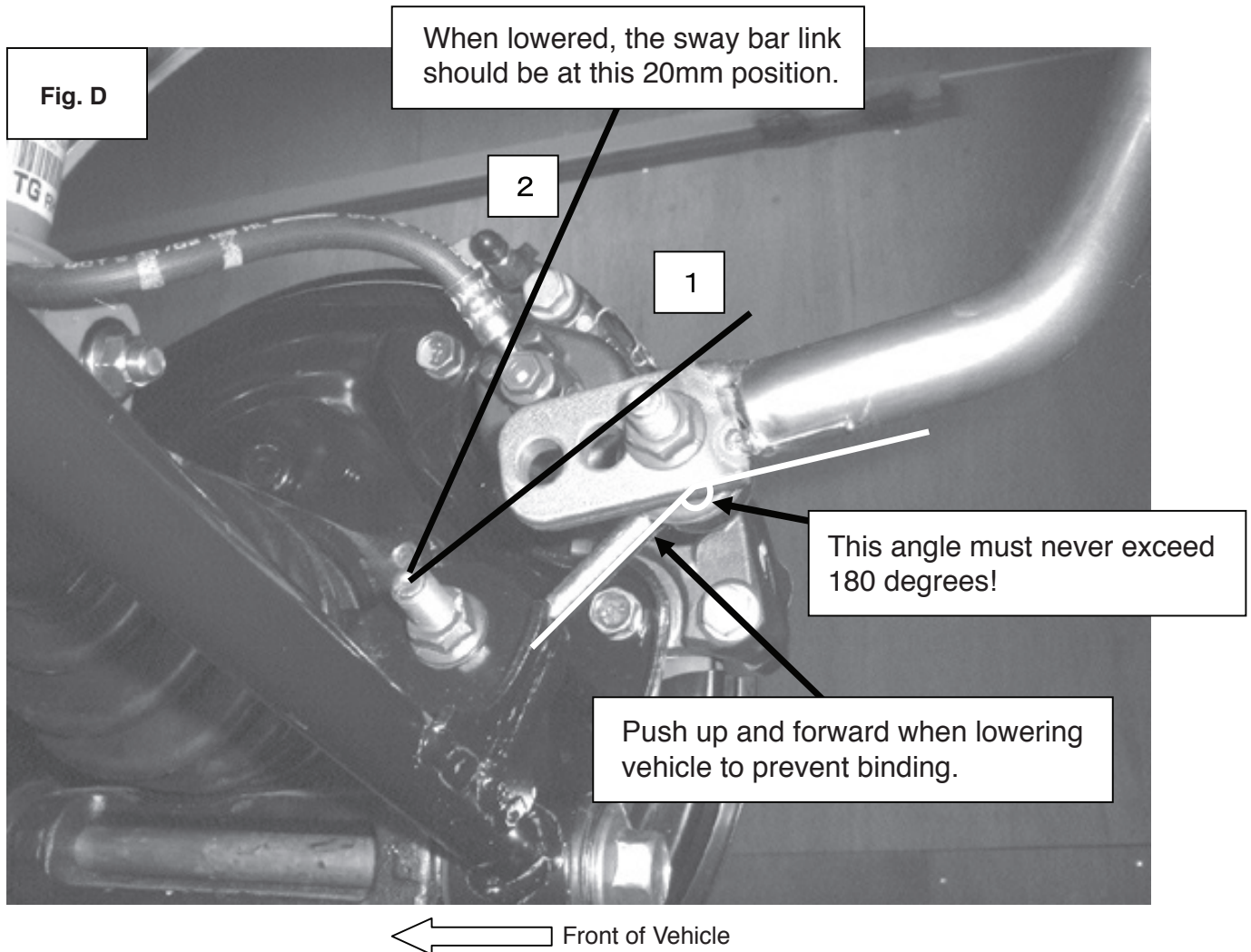

Fig. D



When lowered, the sway bar link should be at this 20mm position.

This angle must never exceed 180 degrees!

Push up and forward when lowering vehicle to prevent binding.

← Front of Vehicle



Warning

**Periodically check and re-torque all nuts and bolts after operating vehicle.