





- Installation Manual -

692 492 C

[Powerbrace Center](#)

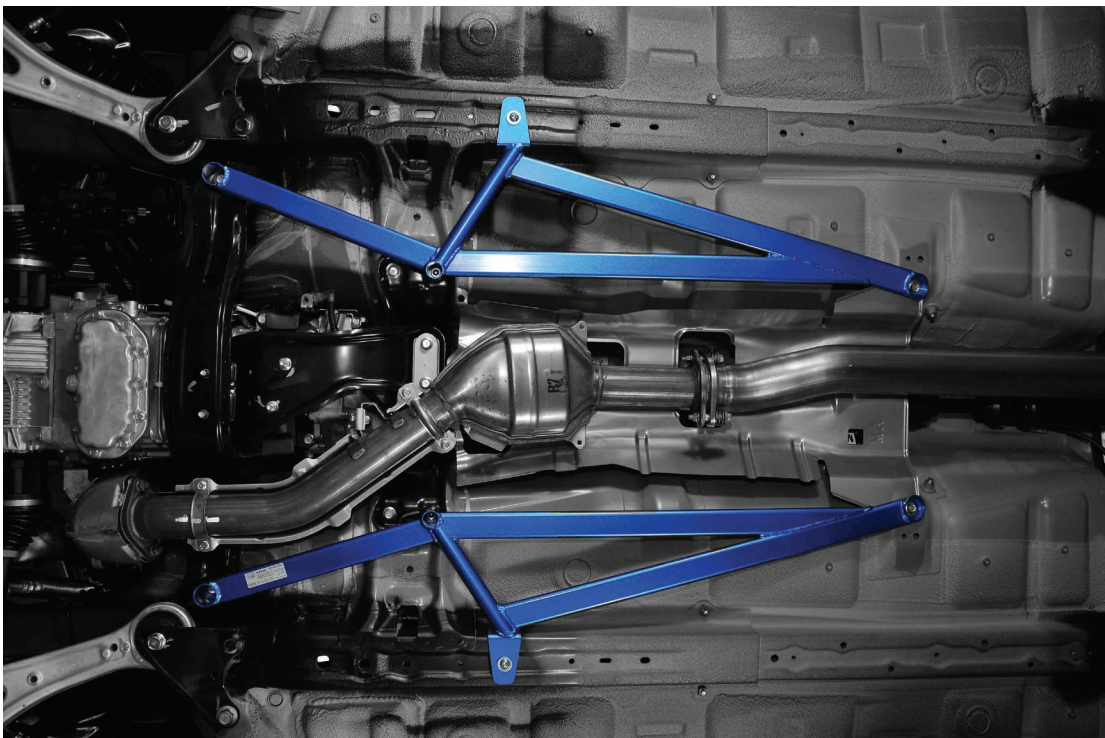
- [Part Number]** 692 492 C
- [Application]** Subaru Impreza WRX STI [GRB,GVB]
Subaru Impreza S-GT [GH8]
Subaru Impreza Sport, XV, XV Hybrid [GP7]
Subaru Impreza G4 [GJ7]
Subaru Forester [SH5] (AT Vehicles Only)
- [Product]** Powerbrace Center
- [Description]** Chassis bracing center mounted
- [Contents]** Nut Fastener Bracket x2
22mm Spacer x2
M10 x 35 Bolt x2
M10 Spring Washer x2
M8x30 Button Bolt x2
M8x20 Bolt x2
M8 Flat Washer (L) x4
M12x25 Flanged Bolt x2
4.5mm Spacer x2



 **NOTE** A car lift is highly recommended for the installation of this product.
Approximate install time: 1.0 hours

[Procedure]

- 1.) Remove the transmission cross member bolts.
*Member indicated as 'A' below does not exist on GH8 (AT) & SH5 (AT)
*It is necessary to remove only one bolt on GH8 (AT) models

 **NOTE** Secure transmission cross member with a jack when removing the bolts to prevent it from falling.

- 2.) Remove the two bolts that hold the heat shield and lightly hammer 20mm of the hole area and make flat.

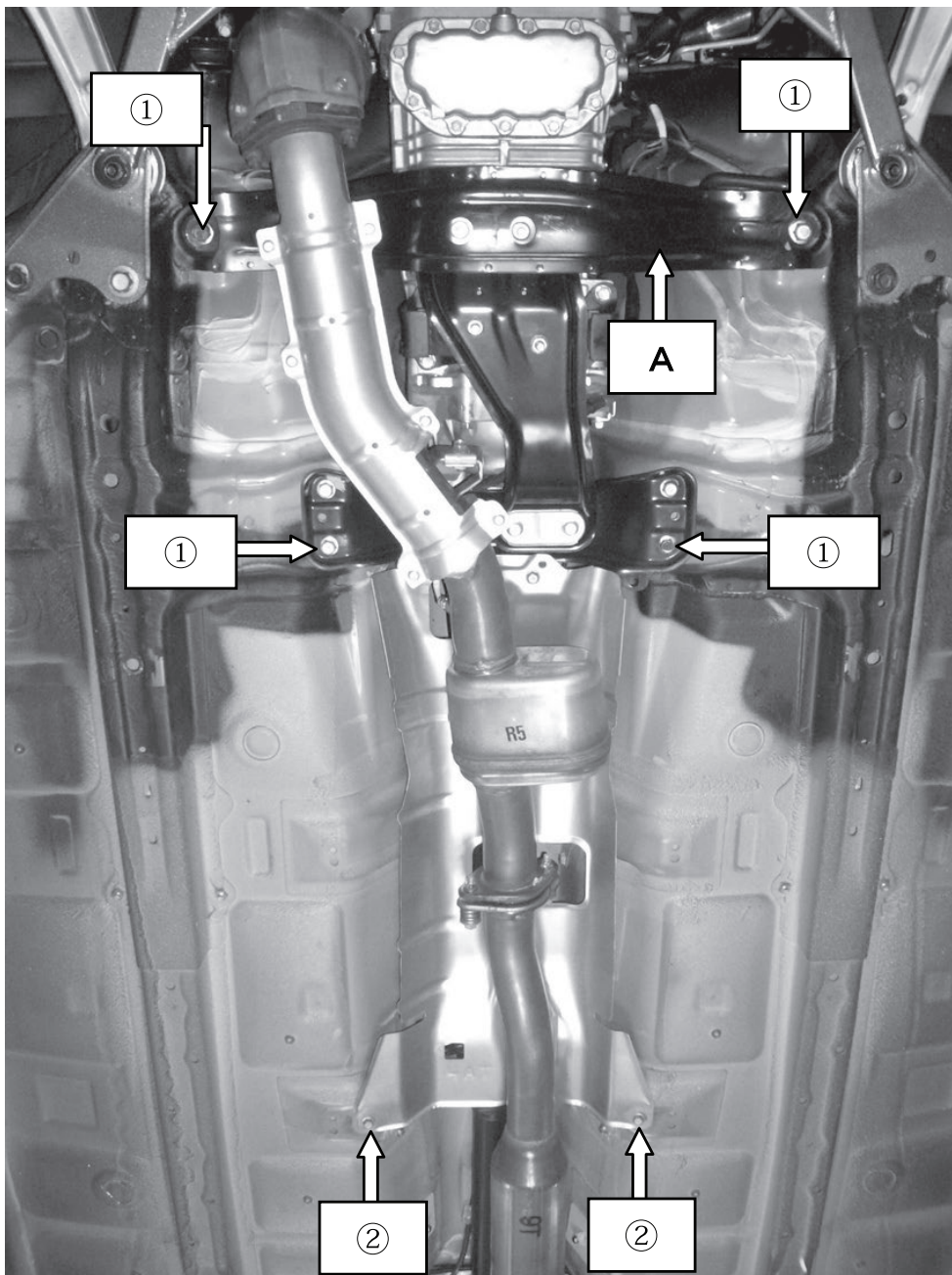

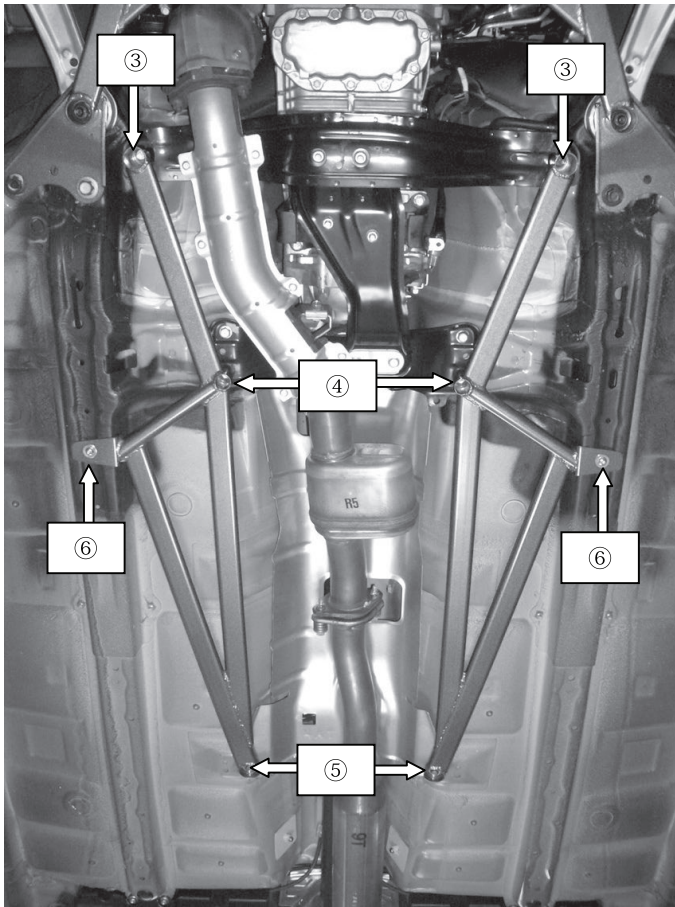

3.) For all MT vehicles, reuse factory bolts here.
Use included M12x25 Flanged Bolt for GH8 (AT) models.
Use included M12x25 Flanged Bolt and 4.5mm Spacers for SH5 (AT) models.

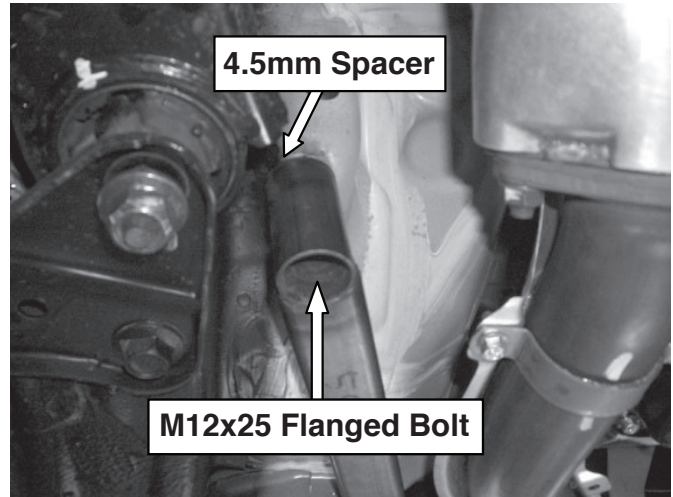

4.) Install included M10x35 Bolts and M10 Spring Washers.
5.) Install included M8x20 Bolt and M8 Washers (L)

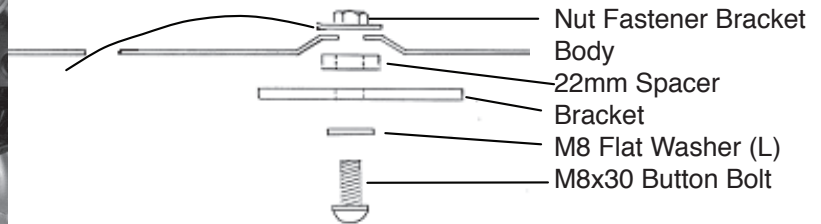
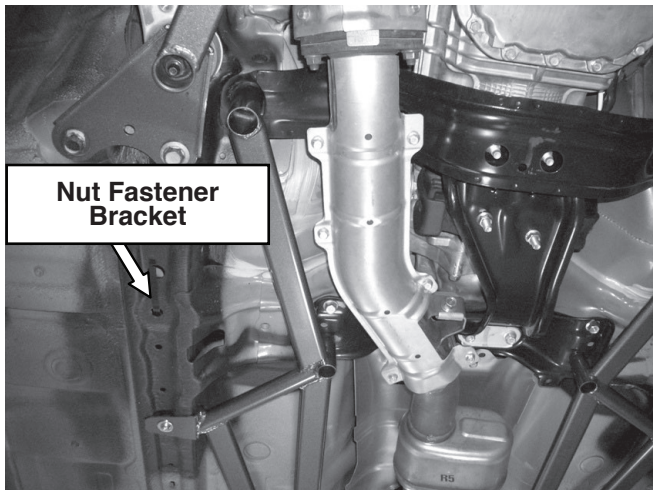

6.) Bend the included Nut Fastener Bracket according to the illustration below and slip inside the indicated hole shown above. Install included 22mm spacer, M8x30 Button Bolt, and M8 Washer (L).



Warning

**Periodically check and re-torque all nuts and bolts after operating vehicle.