

31302**GMC SIERRA, CHEVY SILVERADO****GROSS LOAD CAPACITY WHEN USED AS A WEIGHT CARRYING HITCH: 5,000 LBS. TRAILER WEIGHT & 500 LBS. TONGUE WEIGHT.****GROSS LOAD CAPACITY WHEN USED AS A STRAIGHT LINE PULL: 9,000 LBS. MAX. LINE PULL.**

*** DO NOT EXCEED VEHICLE MANUFACTURER'S RECOMMENDED TOWING CAPACITY. ***

Parts List				
ITEM	QTY	PART NUMBER	DESCRIPTION	
1	1	1/2"	FISHWIRE TOOL	
2	6	1/2-13 x 1 1/4	HEX BOLT	
3	10	HFN 1213	HEX FLANGE NUT	
4	4	1/2-13 x 2 1/2 LG.	CARRIAGE BOLT	
5	4	CM-SP12	.250 x 1.00 x 2.00" SQUARE HOLE SPACER	

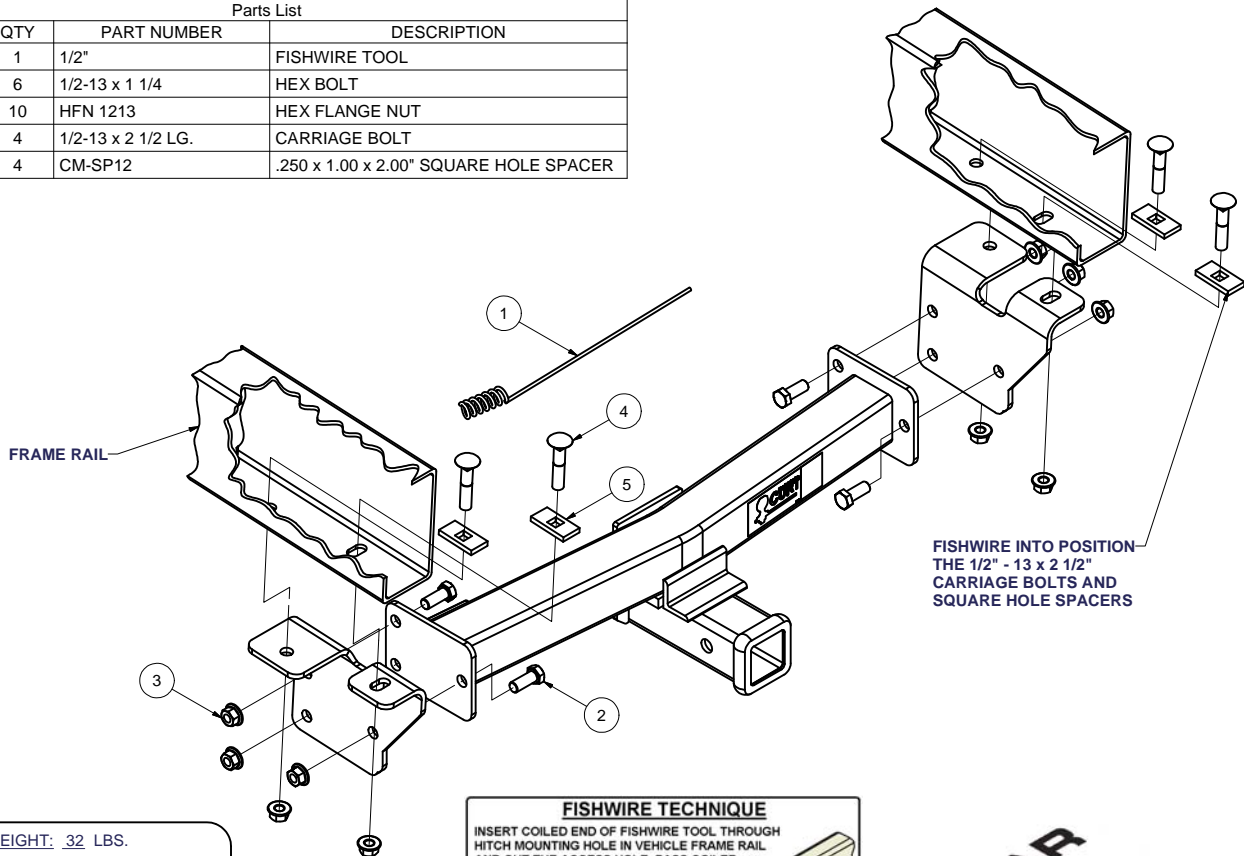

HITCH WEIGHT: 32 LBS.

INSTALL TIME

PROFESSIONAL: 120 MINUTES

NOVICE (DIY): 60 MINUTES

INSTALL NOTES:

- MAY REQUIRE CUTTING
- FISHWIRE

FISHWIRE TECHNIQUE

INSERT COILED END OF FISHWIRE TOOL THROUGH HITCH MOUNTING HOLE IN VEHICLE FRAME RAIL AND OUT THE ACCESS HOLE. PASS COILED END OF FISHWIRE THROUGH SPACER AND THREAD BOLT INTO COIL. KINK WIRE TO KEEP SPACER SEPARATE FROM BOLT AS SHOWN. PULL FISHWIRE, SPACER, AND BOLT THROUGH FRAME AND OUT MOUNTING HOLE. USE FISHWIRE TO GUIDE HITCH DURING MOUNTING AND PREVENT LOSS OF BOLT / SPACER INSIDE FRAME RAIL.

NOTE: SOME VEHICLES MAY FISHWIRE THROUGH END OF FRAME

**INSTALLATION STEPS**

- 1) Models with tow hooks must remove the factory bolt from the underside of the frame at the forward attachment point.
- 2) Fishwire the 1/2" carriage bolts and spacers through the frame as shown.
- 3) Fasten frame brackets to frame using 1/2" flange nuts. Ensure that the brackets are loosely installed to provide adjustment for future installation steps. Reinstall factory fasteners if removal was required.
- 4) Install cross member between brackets and secure with the hex bolts and flange nuts provided.
- 5) Tighten all bolts to proper torque specifications.

Note: Hitch can be installed in a "through bumper" or a "below bumper" configuration by reversing the cross member. Through bumper configuration requires a 3" square hole to be cut into the plastic fascia. Position the hole on the vehicle center line 3 1/2" below the top edge of the plastic fascia.

- 6) Torque 1/2" fasteners to 75 lb-ft.

PERIODICALLY CHECK THIS RECEIVER HITCH TO ENSURE THAT ALL FASTENERS ARE TIGHT AND THAT ALL STRUCTURAL COMPONENTS ARE SOUND.

Curt Manufacturing Inc., warrants this product to be free of defects in material and/or workmanship at the time of retail purchase by the original purchaser. If the product is found to be defective, Curt Manufacturing Inc., may repair or replace the product, at their option, when the product is returned, prepaid, with proof of purchase. Alteration to, misuse of, or improper installation of this product voids the warranty. Curt Manufacturing Inc.'s liability is limited to repair or replacement of products found to be defective, and specifically excludes liability for incidental or consequential loss or damage.

Looking for dependable trailer hitches and towing? Rely on CURT for quality and long-lasting products.