

31199**NISSAN TITAN**

**GROSS LOAD CAPACITY WHEN USED AS A WEIGHT CARRYING HITCH: 5,000 LBS. TRAILER WEIGHT & 500 LBS. TONGUE WEIGHT.
 MAXIMUM STRAIGHT LINE PULL SHOULD NOT EXCEED: 9,000 LBS. TRAILER WEIGHT & 900 LBS. TONGUE WEIGHT**

*****DO NOT EXCEED VEHICLE MANUFACTURER'S RECOMMENDED TOWING CAPACITY.*****

Parts List				
ITEM	QTY	PART NUMBER	DESCRIPTION	
1	4	1/2-13 x 1 1/2	CARRIAGE BOLT	
2	4	HFN 1213	HEX FLANGE NUT	
3	4	M12 x 1.25 x 45	HEX BOLT	
4	2	1/2"	CONICAL TOOTHED WASHER	
5	2	CM-SP32	.188 x 1.50 x 2.00" ROUND HOLE SPACER	
6	4	CM-SP40	.188 x 1.00 x 3.00" SQUARE HOLE SPACER	
7	1	1/2"	FISHWIRE TOOL	

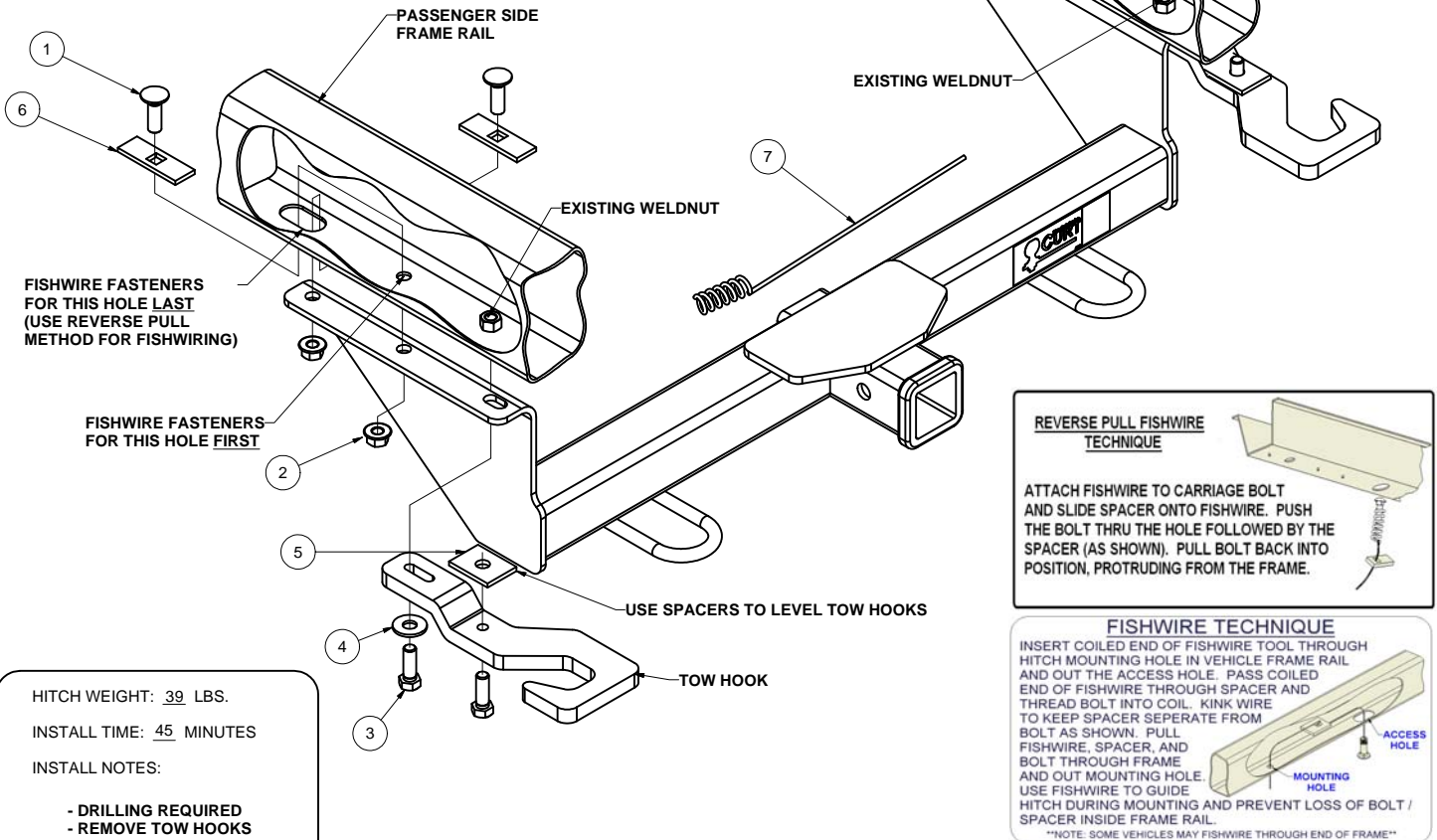

HITCH WEIGHT: 39 LBS.

INSTALL TIME: 45 MINUTES

INSTALL NOTES:

- DRILLING REQUIRED
- REMOVE TOW HOOKS

INSTALLATION STEPS

- 1) Remove tow hooks, re-use later.
- 2) Raise hitch into position. Using hitch as a template, drill center mounting holes on both sides.
- 3) Lower hitch and fishwire fasteners into position as shown.
(Note: fishwire fasteners for drilled holes first then fishwire for remaining holes)
- 4) Raise hitch back into position and install hex nuts.
- 5) Re-install tow hooks, using holes in hitch. Use spacer blocks as needed to level tow hooks.
- 6) Torque all M12 fasteners to 65 lb-ft. and all 1/2" fasteners to 75 lb-ft.

PERIODICALLY CHECK THIS RECEIVER HITCH TO ENSURE THAT ALL FASTENERS ARE TIGHT AND THAT ALL STRUCTURAL COMPONENTS ARE SOUND.

Curt Manufacturing Inc., warrants this product to be free of defects in material and/or workmanship at the time of retail purchase by the original purchaser. If the product is found to be defective, Curt Manufacturing Inc., may repair or replace the product, at their option, when the product is returned, prepaid, with proof of purchase. Alteration to, misuse of, or improper installation of this product voids the warranty. Curt Manufacturing Inc.'s liability is limited to repair or replacement of products found to be defective, and specifically excludes liability for incidental or consequential loss or damage.

*****DO NOT EXCEED VEHICLE MANUFACTURER'S RECOMMENDED TOWING CAPACITY*****.

FRONT MOUNTED ACCESSORIES

1) Do not exceed front axle Gross Weight Rating (GAWR). Consult owners manual or specification plate located on driver's door frame. Measure gross front axle weight by placing front wheels of loaded vehicle on a scale.

WARNING: Exceeding GAWR may overload the front axle and/or suspension. This could result in **accident, property damage and personal injury.**

- 2) Reposition front mounted license plate if obstructed.
- 3) Do not obstruct vehicle lights.
- 4) Allow free air flow into grille opening.
- 5) Rear wheel traction may be reduced. This could effect handling. Reduce speed and drive with caution.
- 6) Accessories extend front of vehicle. This may reduce approach angle. Use caution when parking and maneuvering.
- 7) Do not obstruct driver view.

VEHICLE RECOVERY AND WINCHING TIPS

1) Use OEM tow hooks, recovery eyes or a clevis mount for attachment of a tow strap or winch cable.

WARNING: NEVER use a ball and/or ball mount as an anchor point for tow strap or winch cable. Severe personal injury or death could result.

- 2) Observe winch manufacturer's recommendations, cautions and warnings.
- 3) Attach return cable to tow hook or recovery eye when using a snatch block (See figure 1).

CAUTION: Do not attach return cable to winch mount. This may overload winch mount and/or front mounted receiver.

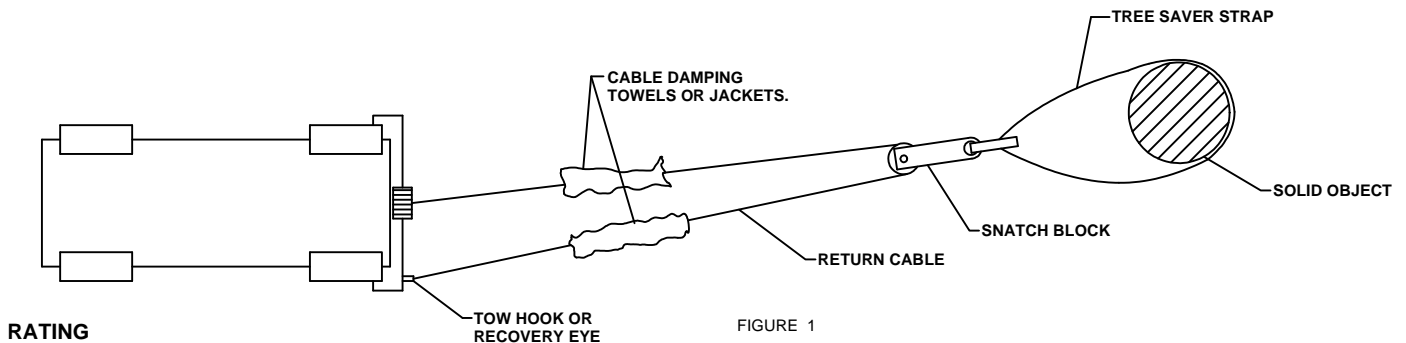

RATING

For **Maximum** line pull rating, winch cable must not exceed:

- 15 degree angle up or down from horizontal (See Figure 2).
- 45 degree angle left or right from straight ahead (See Figure 3).

CAUTION: Exceeding the maximum line pull rating may over load winch, winch mount, and/or front mounted receiver.

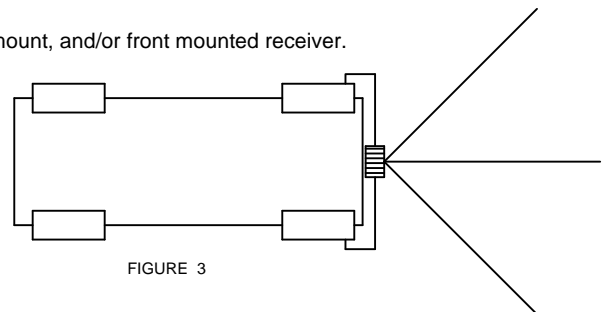
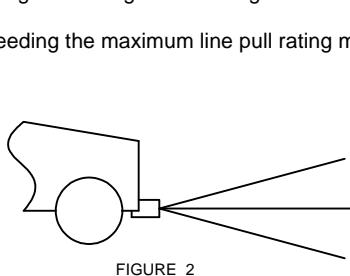

Curt Manufacturing Inc., warrants this product to be free of defects in material and/or workmanship at the time of retail purchase by the original purchaser. If the product is found to be defective, Curt Manufacturing Inc., may repair or replace the product, at their option, when the product is returned, prepaid, with proof of purchase. Alteration to, misuse of, or improper installation of this product voids the warranty. Curt Manufacturing Inc.'s liability is limited to repair or replacement of products found to be defective, and specifically excludes liability for incidental or consequential loss or damage.