

31048

2002-2004, JEEP GRAND CHEROKEE

GROSS LOAD CAPACITY WHEN USED AS A WEIGHT CARRYING HITCH: 3500 LBS. TRAILER WEIGHT & 350 LBS. TONGUE WEIGHT.

GROSS LOAD CAPACITY WHEN USED AS A STRAIGHT LINE PULL: 9,000 LBS. MAX. LINE PULL.

***** DO NOT EXCEED VEHICLE MANUFACTURER'S RECOMMENDED TOWING CAPACITY. *****

Parts List				
ITEM	QTY	PART NUMBER	DESCRIPTION	
1	8	7/16-14 x 1	CARRIAGE BOLT	
2	1	7/16-14 x 1 1/4	CARRIAGE BOLT	
3	9	7/16-14	HEX FLANGE NUT	
4	1	CM-SP2	.250 x .88 x 2.25" SQUARE HOLE SPACER	
5	1	7_16 FISHWIRE	7/16" FISHWIRE	

TOOLS REQUIRED
RATCHET
4" EXTENSION
18mm SOCKET
11/16" SOCKET
TORQUE WRENCH
DRILL
1/2" DRILL BIT

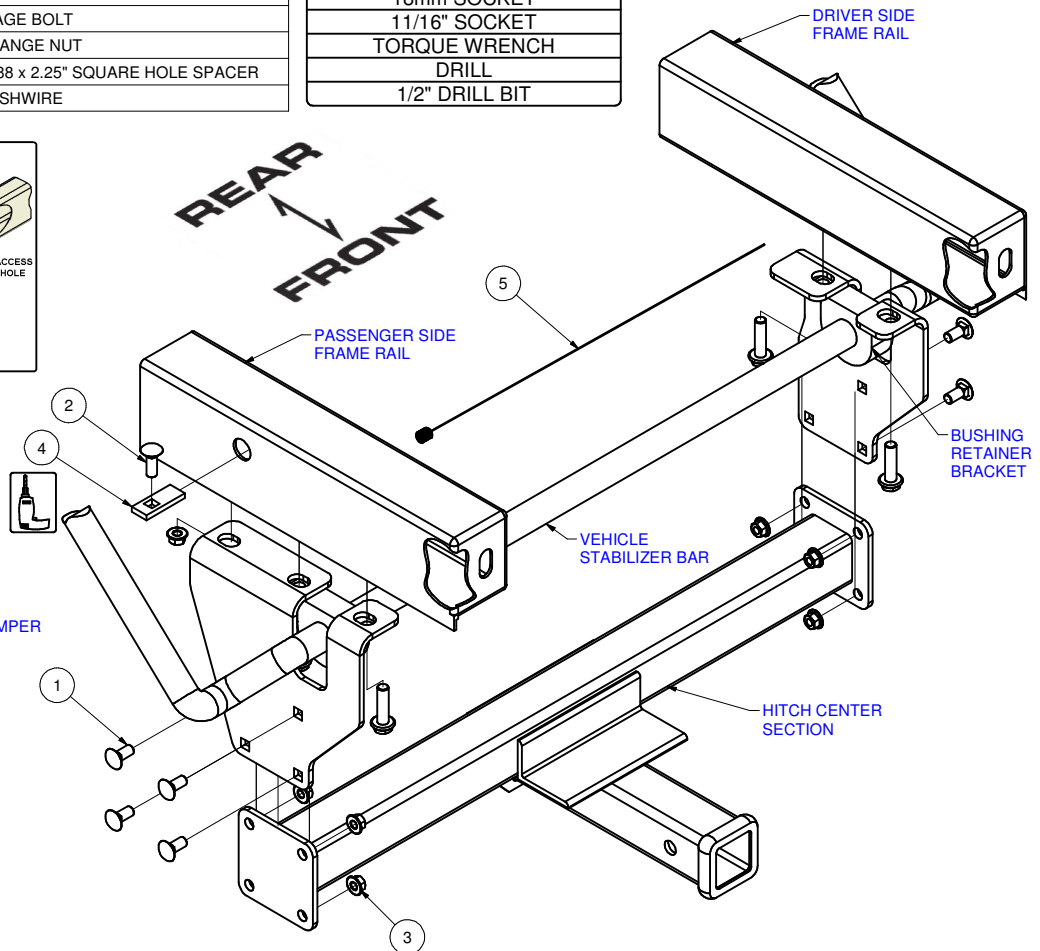
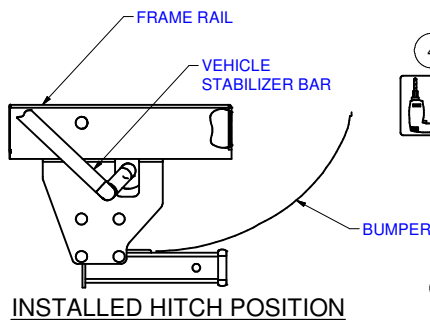
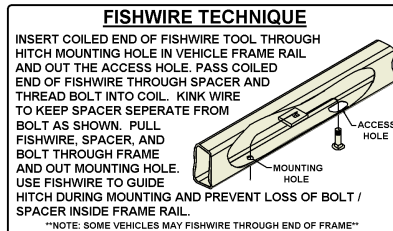

HITCH WEIGHT: 45 LBS.

INSTALL TIME

PROFESSIONAL: 45 MINUTES

NOVICE (DIY): 90 MINUTES

INSTALL NOTES:

- DRILLING REQUIRED
- FISHWIRE HARDWARE

INSTALLATION STEPS

1. Remove front stabilizer bar bushing retaining bolts (save bolts for reinstallation).
2. Slide driver's side plate into place, in-between frame and bushing retaining bracket. Replace the 12mm bolts. Leave hardware loose until all bolts are in.
3. Repeat step 2 for passenger side.
4. Locate back slot in passenger side plate and drill 1/2" dia. hole into frame.
5. Fishwire CM-SP2 spacer and 7/16" x 1.25" long carriage bolt through hole on outside of frame.
6. Slide hitch, center section, between side plates. Use 7/16" carriage bolts and nuts provided with kit to connect to side plates.
7. Torque all 12mm hardware to 60 ft - lb, and all 7/16" hardware to 50 ft - lb.

PERIODICALLY CHECK THIS RECEIVER HITCH TO ENSURE THAT ALL FASTENERS ARE TIGHT AND THAT ALL STRUCTURAL COMPONENTS ARE SOUND.

Curt Manufacturing Inc., warrants this product to be free of defects in material and/or workmanship at the time of retail purchase by the original purchaser. If the product is found to be defective, Curt Manufacturing Inc., may repair or replace the product, at their option, when the product is returned, prepaid, with proof of purchase. Alteration to, misuse of, or improper installation of this product voids the warranty. Curt Manufacturing Inc.'s liability is limited to repair or replacement of products found to be defective, and specifically excludes liability for incidental or consequential loss or damage.

31048 INSTALLATION INSTRUCTIONS



Safety glasses should be worn at all times while installing this product.

YEARS: 2002-2004

MAKE: JEEP

MODEL: GRAND CHEROKEE

STYLE: SUV

WARNING: NEVER EXCEED YOUR VEHICLE MANUFACTURER'S RECOMMENDED TOWING CAPACITY

WEIGHT CARRYING:
 TRAILER WEIGHT: 3500 LBS.
 TONGUE WEIGHT: 350 LBS.

**GROSS LOAD CAPACITY WHEN USED AS A STRAIGHT LINE PULL:
 9,000 LBS MAX.**

INSTALLATION TIME: 45 MIN.

THE INSTALL TIME LISTED IS FOR PROFESSIONAL INSTALLERS. IF YOU ARE HESITANT TO UNDERTAKE THIS TASK ON YOUR OWN, CONTACT AN AUTHORIZED CURT INSTALLER FOR ADDITIONAL ASSISTANCE.

INSTALLATION TIPS:







1. BEFORE YOU BEGIN INSTALLATION, READ ALL INSTRUCTIONS THOROUGHLY.
2. TO EASE INSTALLATION, 2 PEOPLE MAY BE REQUIRED.
3. USING PROPER TOOLS WILL GREATLY IMPROVE THE QUALITY OF THE INSTALL AND REDUCE THE TIME REQUIRED.

VEHICLE PHOTO:



REPRESENTATIVE PHOTO

INSTALLATION REQUIRES:

 RATCHET	 18mm 1 1/16" SOCKET	 4" SOCKET EXTENSION
 POWER DRILL	 DRILL BIT 1/2"	 TORQUE WRENCH

LEVEL OF DIFFICULTY: MODERATE

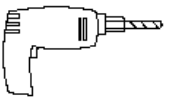
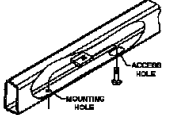
EASY	MODERATE	HARD
	DRILLING REQUIRED	
	FISHWIRE REQUIRED	

HITCH ILLUSTRATION:

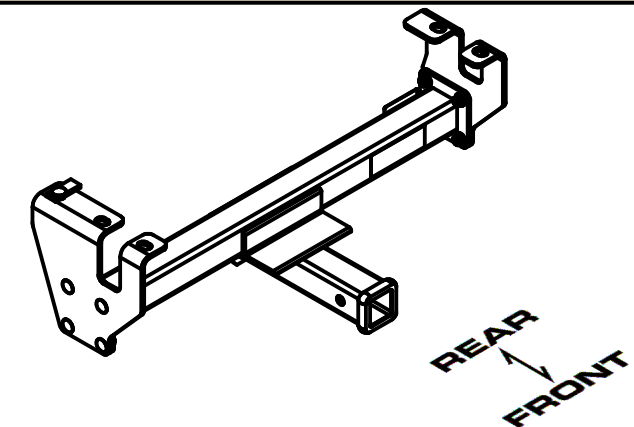

MAKE SURE YOUR HITCH MATCHES

PERIODICALLY CHECK THIS RECEIVER HITCH TO ENSURE ALL FASTENERS ARE TIGHT AND ALL STRUCTURAL COMPONENTS ARE SOUND

CURT Manufacturing Inc. warrants this product to be free of defects in material and/or workmanship at the time of retail purchase by the original purchaser. If the product is found to be defective, Curt Manufacturing Inc. may repair or replace the product at their option, when the product is returned, prepaid, with proof of purchase. Alteration to, misuse of, or improper installation of this product voids the warranty. Curt Manufacturing Inc.'s liability is limited to repair or replacement of products found to be defective, and specifically excludes liability for incidental or consequential loss or damage.

INSTALLATION WALKTHROUGH:

Parts List			
ITEM	QTY	PART NUMBER	DESCRIPTION
1	8	7/16-14 x 1	CARRIAGE BOLT
2	1	7/16-14 x 1 1/4	CARRIAGE BOLT
3	1	CM-SP2	.250 x .88 x 2.25" SQUARE HOLE SPACER
4	9	7/16-14	HEX FLANGE NUT
5	1	7_16 FISHWIRE	7/16" FISHWIRE

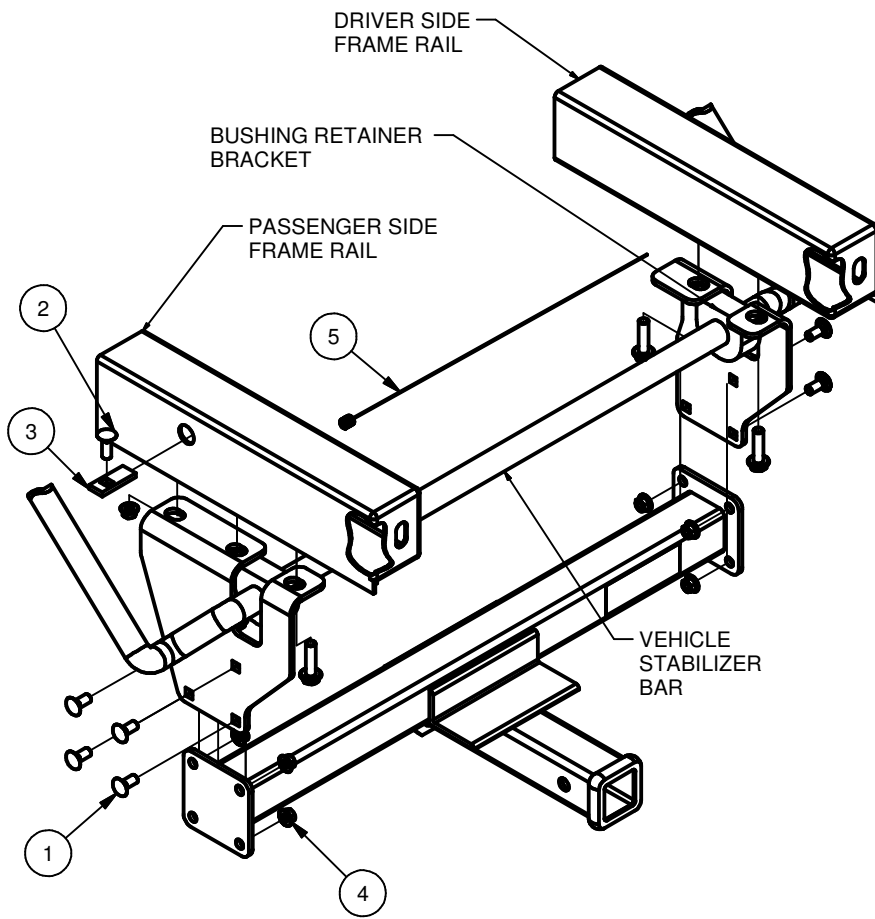

1. Remove front stabilizer bar bushing retaining bolts (save bolts for reinstallation)



2. Slide drivers side plate into place, inbetween frame and bushing retaining bracket. Reinstall the 12mm bolts. Leave hardware loose until all bolts are installed.



INSTALLATION WALKTHROUGH:

3. Slide passenger side plate into place, inbetween frame and retaining bracket. Reinstall the 12mm bolts. Leave hardware loose until all bolts are in.



4. Locate back slot in passenger side plate and drill 1/2" dia. hole into frame. Fishwire CM-SP2 spacer and 7/16 x 1.25" long carriage bolt through hole on outside of frame.



5. Slide hitch, center section, inbetween slide plates, use 7/16" carriage bolts and nuts, to connect to side plates.

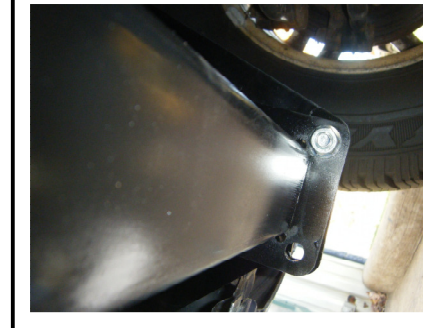

6. Torque all 12mm bolts to 60 ft - lb, and all 7/16" bolts to 50 ft - lb.

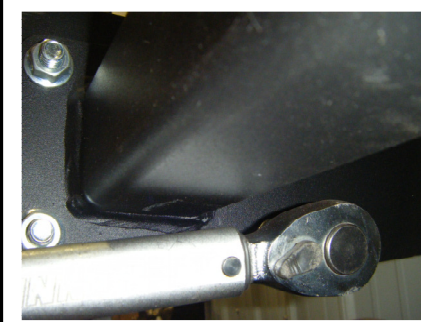

***DO NOT EXCEED VEHICLE MANUFACTURER'S RECOMMENDED TOWING CAPACITY ***.

FRONT MOUNTED ACCESSORIES

- 1) Do not exceed front axle Gross Weight Rating (GAWR). Consult owners manual or specification plate located on driver's door frame. Measure gross front axle weight by placing front wheels of loaded vehicle on a scale.

WARNING: Exceeding GAWR may overload the front axle and/or suspension. This could result in **accident, property damage and personal injury.**

- 2) Reposition front mounted license plate if obstructed.
- 3) Do not obstruct vehicle lights.
- 4) Allow free air flow into grille opening.
- 5) Rear wheel traction may be reduced. This could effect handling. Reduce speed and drive with caution.
- 6) Accessories extend front of vehicle. This may reduce approach angle. Use caution when parking and maneuvering.
- 7) Do not obstruct driver view.

VEHICLE RECOVERY AND WINCHING TIPS

- 1) Use OEM tow hooks, recovery eyes or a clevis mount for attachment of a tow strap or winch cable.

WARNING: NEVER use a ball and/or ball mount as an anchor point for tow strap or winch cable. Severe personal injury or death could result.

- 2) Observe winch manufacturer's recommendations, cautions and warnings.
- 3) Attach return cable to tow hook or recovery eye when using a snatch block (See figure 1).

CAUTION: Do not attach return cable to winch mount. This may overload winch mount and/or front mounted receiver.

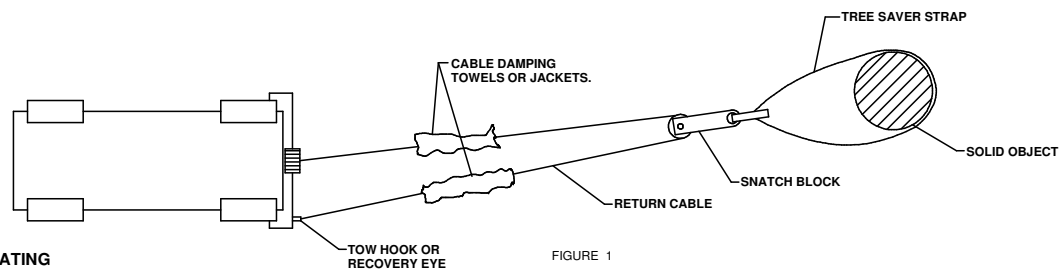

RATING

For **Maximum** line pull rating, winch cable must not exceed:

- 15 degree angle up or down from horizontal (See Figure 2).
- 45 degree angle left or right from straight ahead (See Figure 3).

CAUTION: Exceeding the maximum line pull rating may over load winch, winch mount, and/or front mounted receiver.

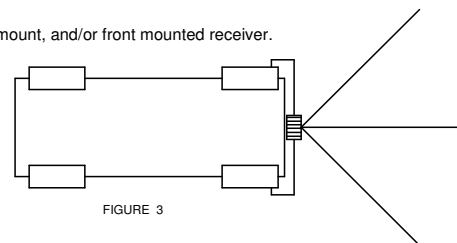
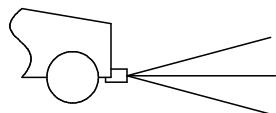

Curt Manufacturing Inc., warrants this product to be free of defects in material and/or workmanship at the time of retail purchase by the original purchaser. If the product is found to be defective, Curt Manufacturing Inc., may repair or replace the product, at their option, when the product is returned, prepaid, with proof of purchase. Alteration to, misuse of, or improper installation of this product voids the warranty. Curt Manufacturing Inc.'s liability is limited to repair or replacement of products found to be defective, and specifically excludes liability for incidental or consequential loss or damage.