

YEARS: 2010-PRESENT

MAKE: HYUNDAI

MODEL: SANTA FE

STYLE: SUV

WARNING: NEVER EXCEED YOUR VEHICLE MANUFACTURER'S RECOMMENDED TOWING CAPACITY

WEIGHT CARRYING:
 TRAILER WEIGHT: 3,500 LBS.
 TONGUE WEIGHT: 350 LBS.

**GROSS LOAD CAPACITY WHEN USED AS A STRAIGHT LINE PULL:
 9,000 LBS MAX.**

INSTALLATION TIME: 45 MIN.

THE INSTALL TIME LISTED IS FOR PROFESSIONAL INSTALLERS. IF YOU ARE HESITANT TO UNDERTAKE THIS TASK ON YOUR OWN, CONTACT AN AUTHORIZED CURT INSTALLER FOR ADDITIONAL ASSISTANCE.

INSTALLATION TIPS:

- BEFORE YOU BEGIN INSTALLATION, READ ALL INSTRUCTIONS THOROUGHLY.
- TO EASE INSTALLATION, 2 PEOPLE MAY BE REQUIRED.
- USING PROPER TOOLS WILL GREATLY IMPROVE THE QUALITY OF THE INSTALL AND REDUCE THE TIME REQUIRED.

VEHICLE PHOTO:



REPRESENTATIVE PHOTO

INSTALLATION REQUIRES:

RATCHET	6" SOCKET EXTENSION	12mm 11/16" 3/4" SOCKET
BOXED END WRENCH 11/16"	PHILLIPS SCREW DRIVER	DIE GRINDER
TORQUE WRENCH	AVIATION SHEARS	SAFETY GLASSES

LEVEL OF DIFFICULTY: MODERATE

EASY	MODERATE	HARD
	FISHWIRE HARDWARE	
	HOLE ENLARGMENT	
	OPTIONAL UNDERBODY PANEL TRIMMING	

HITCH ILLUSTRATION:

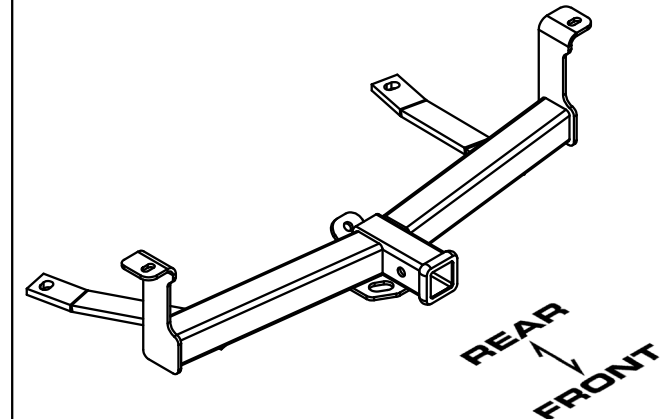

MAKE SURE YOUR HITCH MATCHES

PERIODICALLY CHECK THIS RECEIVER HITCH TO ENSURE ALL FASTENERS ARE TIGHT AND ALL STRUCTURAL COMPONENTS ARE SOUND

CURT Manufacturing Inc. warrants this product to be free of defects in material and/or workmanship at the time of retail purchase by the original purchaser. If the product is found to be defective, Curt Manufacturing Inc. may repair or replace the product at their option, when the product is returned, prepaid, with proof of purchase. Alteration to, misuse of, or improper installation of this product voids the warranty. Curt Manufacturing Inc.'s liability is limited to repair or replacement of products found to be defective, and specifically excludes liability for incidental or consequential loss or damage.

INSTALLATION WALKTHROUGH:

Parts List			
ITEM	QTY	PART NUMBER	DESCRIPTION
1	1	1/2-13 x 1 3/4	CARRIAGE BOLT
2	1	CM-SP53	.250 x 1.50 x 3.00" SQUARE HOLE SPACER
3	1	HFN 1213	HEX FLANGE NUT
4	4	CM-SP11	.250 x 1.00 x 2.50" SQUARE HOLE SPACER
5	2	7/16-14 x 1 1/2	CARRIAGE BOLT
6	4	7/16-14	HEX FLANGE NUT
7	1	7/16-14 x 4	CARRIAGE BOLT
8	1	7/16-14 x 3 1/2"	CARRIAGE BOLT
9	2	7_16 FISHWIRE	7/16" FISHWIRE

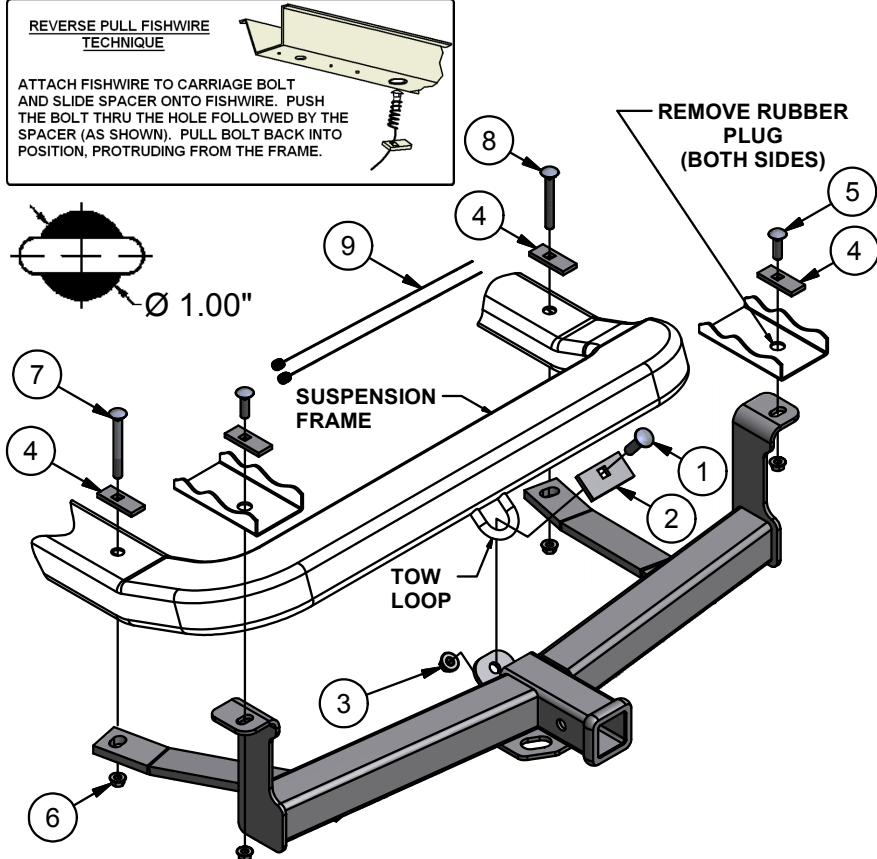

1. Remove the underbody panel on the front of the vehicle by removing the (8) M8 bolts and (6) phillips head plastic fasteners. Save for reinstallation or return to customer with hardware, should the hitch be removed.



2. Remove the (2) rubber plugs in the frame rail. Enlarge these holes to accept a spacer (CM-SP11) and a carriage bolt as shown in the diagram.

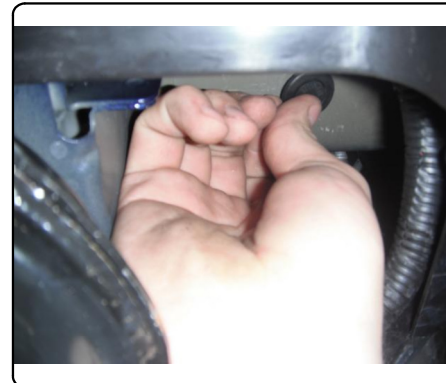

INSTALLATION WALKTHROUGH:

3. Place the 4" carriage bolt and spacer (CM-SP11) into position through the top of the suspension frame on the passenger side. Place the 3 1/2" carriage bolt and spacer (CM-SP11) through the top of the suspension frame on the driver side. Place the 1/2" x 1 3/4" carriage bolt and spacer (CM-SP53) on the tow loop as shown. Fishwire the remaining bolts and spacers into the frame as shown on page 2 in the "REVERSE PULL FISHWIRE TECHNIQUE". Leave the fishwires attached.

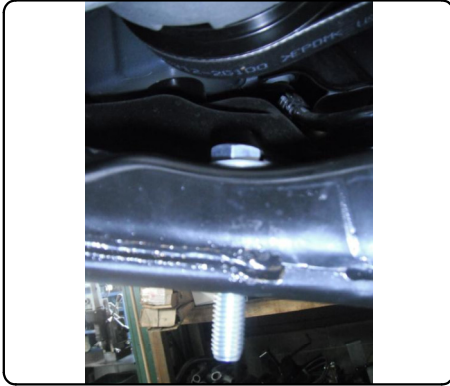

4. Raise hitch into position feeding the fishwires through the mounting holes. Loosely install the hex flange nuts provided as shown.



5. Torque all 7/16" hardware to 50 lb-ft and all 1/2" hardware to 75 lb-ft.

Optional: Trim underbody panel as required to be re-assembled to the vehicle around hitch.



31034**HYUNDAI SANTA FE**

10/18/2010

GROSS LOAD CAPACITY WHEN USED AS A WEIGHT CARRYING HITCH: 3,500 LBS. TRAILER WEIGHT & 350 LBS. TONGUE WEIGHT.
 GROSS LOAD CAPACITY WHEN USED AS A STRAIGHT LINE PULL: 9,000 LBS. MAX. LINE PULL.

***** DO NOT EXCEED VEHICLE MANUFACTURER'S RECOMMENDED TOWING CAPACITY. *****

Parts List			
ITEM	QTY	PART NUMBER	DESCRIPTION
1	1	1/2-13 x 1 3/4	CARRIAGE BOLT
2	1	CM-SP53	.250 x 1.50 x 3.00" SQUARE HOLE SPACER
3	1	HFN 1213	HEX FLANGE NUT
4	4	CM-SP11	.250 x 1.00 x 2.50" SQUARE HOLE SPACER
5	2	7/16-14 x 1 1/2	CARRIAGE BOLT
6	4	7/16-14	HEX FLANGE NUT
7	1	7/16-14 x 4	CARRIAGE BOLT
8	1	7/16-14 x 3 1/2"	CARRIAGE BOLT
9	2	7_16 FISHWIRE	7/16" FISHWIRE

TOOLS REQUIRED
RATCHET
6" EXTENSION
12mm, 11/16", 3/4" SOCKETS
11/16" BOXED END WRENCH
PHILLIPS SCREW DRIVER
DIE GRINDER
SHEARS
TORQUE WRENCH

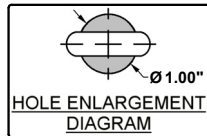
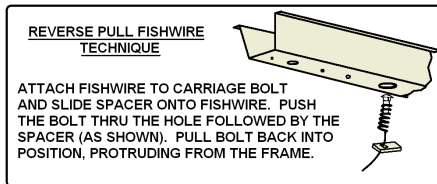

EXISTING HOLE (BOTH SIDES)

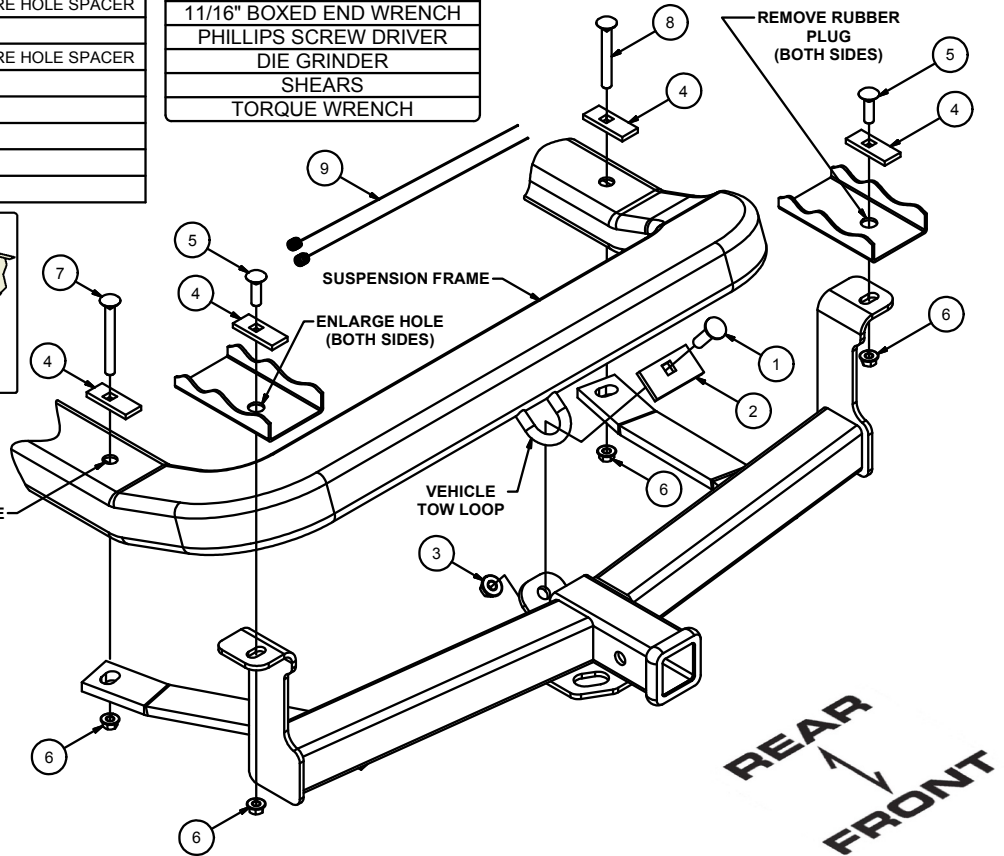

HITCH WEIGHT: 37 LBS.

INSTALL TIME

PROFESSIONAL: 45 MINUTES

NOVICE (DIY): 90 MINUTES

INSTALL NOTES:

- HOLE ENLARGMENT REQUIRED
- UNDERBODY PANEL TRIMMING / REMOVAL
- FISHWIRE FASTENERS

INSTALLATION STEPS

1. Remove the underbody panel on the front of the vehicle by removing the (8) M8 bolts and (6) phillips head plastic fasteners. Save for reinstallation or return to customer with hardware, should the hitch be removed.
2. Remove the (2) rubber plugs in the frame rail. Enlarge these holes to accept a spacer (CM-SP11) and a carriage bolt as shown in the diagram above.
3. Place the 4" carriage bolt and spacer (CM-SP11) into position through the top of the suspension frame on the passenger side. Place the 3 1/2" carriage bolt and spacer (CM-SP11) through the top of the suspension frame on the driver side. Place the 1/2" x 1 3/4" carriage bolt and spacer (CM-SP53) on the tow loop as shown. Fishwire the remaining bolts and spacers into the frame as shown above in the "REVERSE PULL FISHWIRE TECHNIQUE". Leave the fishwires attached.
4. Raise hitch into position feeding the fishwires though the mounting holes. Loosely install the hex flange nuts provided as shown.
5. Torque all 7/16" hardware to 50 lb-ft and all 1/2" hardware to 75 lb-ft.

Optional: Trim underbody panel as required to be re-assembled to the vehicle around hitch.

PERIODICALLY CHECK THIS RECEIVER HITCH TO ENSURE THAT ALL FASTENERS ARE TIGHT AND THAT ALL STRUCTURAL COMPONENTS ARE SOUND.

Curt Manufacturing Inc., warrants this product to be free of defects in material and/or workmanship at the time of retail purchase by the original purchaser. If the product is found to be defective, Curt Manufacturing Inc., may repair or replace the product, at their option, when the product is returned, prepaid, with proof of purchase. Alteration to, misuse of, or improper installation of this product voids the warranty. Curt Manufacturing Inc.'s liability is limited to repair or replacement of products found to be defective, and specifically excludes liability for incidental or consequential loss or damage.

*****DO NOT EXCEED VEHICLE MANUFACTURER'S RECOMMENDED TOWING CAPACITY ***.**

FRONT MOUNTED ACCESSORIES

1) Do not exceed front axle Gross Weight Rating (GAWR). Consult owners manual or specification plate located on driver's door frame. Measure gross front axle weight by placing front wheels of loaded vehicle on a scale.

WARNING: Exceeding GAWR may overload the front axle and/or suspension. This could result in **accident, property damage and personal injury.**

- 2) Reposition front mounted license plate if obstructed.
- 3) Do not obstruct vehicle lights.
- 4) Allow free air flow into grille opening.
- 5) Rear wheel traction may be reduced. This could effect handling. Reduce speed and drive with caution.
- 6) Accessories extend front of vehicle. This may reduce approach angle. Use caution when parking and maneuvering.
- 7) Do not obstruct driver view.

VEHICLE RECOVERY AND WINCHING TIPS

1) Use OEM tow hooks, recovery eyes or a clevis mount for attachment of a tow strap or winch cable.

WARNING: NEVER use a ball and/or ball mount as an anchor point for tow strap or winch cable. Severe personal injury or death could result.

- 2) Observe winch manufacturer's recommendations, cautions and warnings.
- 3) Attach return cable to tow hook or recovery eye when using a snatch block (See figure 1).

CAUTION: Do not attach return cable to winch mount. This may overload winch mount and/or front mounted receiver.

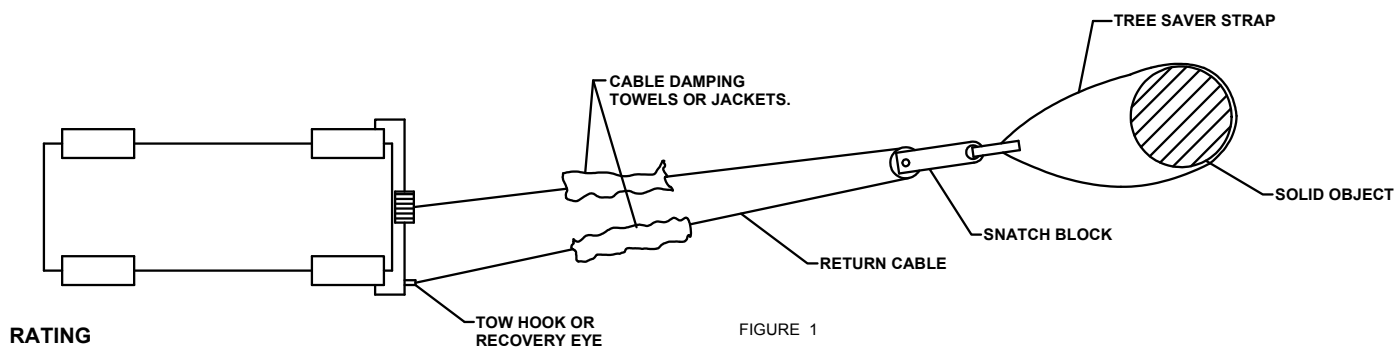

RATING

For **Maximum** line pull rating, winch cable must not exceed:

- 15 degree angle up or down from horizontal (See Figure 2).
- 45 degree angle left or right from straight ahead (See Figure 3).

CAUTION: Exceeding the maximum line pull rating may over load winch, winch mount, and/or front mounted receiver.

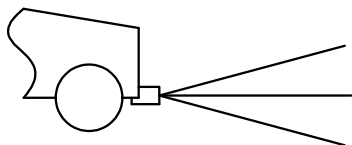

FIGURE 2

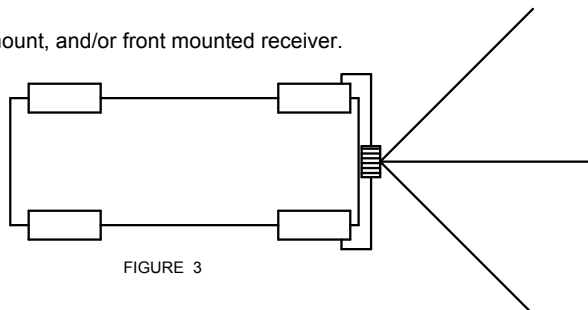

FIGURE 3

Curt Manufacturing Inc., warrants this product to be free of defects in material and/or workmanship at the time of retail purchase by the original purchaser. If the product is found to be defective, Curt Manufacturing Inc., may repair or replace the product, at their option, when the product is returned, prepaid, with proof of purchase. Alteration to, misuse of, or improper installation of this product voids the warranty. Curt Manufacturing Inc.'s liability is limited to repair or replacement of products found to be defective, and specifically excludes liability for incidental or consequential loss or damage.