

YEARS: 2011

MAKE: JEEP / DODGE

MODEL: GRAND CHEROKEE / DURANGO

STYLE: SUV

WARNING: NEVER EXCEED YOUR VEHICLE MANUFACTURER'S RECOMMENDED TOWING CAPACITY

WEIGHT CARRYING:
 TRAILER WEIGHT: 3,000 LBS.
 TONGUE WEIGHT: 300 LBS.

**GROSS LOAD CAPACITY WHEN USED AS A STRAIGHT LINE PULL:
 9,000 LBS MAX.**

INSTALLATION TIME: 35 MIN.

THE INSTALL TIME LISTED IS FOR PROFESSIONAL INSTALLERS. IF YOU ARE HESITANT TO UNDERTAKE THIS TASK ON YOUR OWN, CONTACT AN AUTHORIZED CURT INSTALLER FOR ADDITIONAL ASSISTANCE.

INSTALLATION TIPS:

1. BEFORE YOU BEGIN INSTALLATION, READ ALL INSTRUCTIONS THOROUGHLY.
2. TO EASE INSTALLATION, 2 PEOPLE MAY BE REQUIRED.
3. USING PROPER TOOLS WILL GREATLY IMPROVE THE QUALITY OF THE INSTALL AND REDUCE THE TIME REQUIRED.

VEHICLE PHOTO:



REPRESENTATIVE PHOTO

INSTALLATION REQUIRES:

 POWER DRILL	 DRILL BIT 9/16"	 DIE GRINDER
 RATCHET	 10mm 13mm 18mm 3/4" SOCKET	 TORQUE WRENCH
 TAPE MEASURE	 MARKER	 UTILITY KNIFE
 SAFETY GLASSES		

LEVEL OF DIFFICULTY: MODERATE

EASY	MODERATE	CHALLENGING
	DRILLING REQUIRED	
	ENLARGE (4) HOLES	
	FISHWIRE HARDWARE	
	REVERSE FISHWIRE HARDWARE	
	OPTIONAL UNDERBODY PANEL TRIMMING	

HITCH ILLUSTRATION:

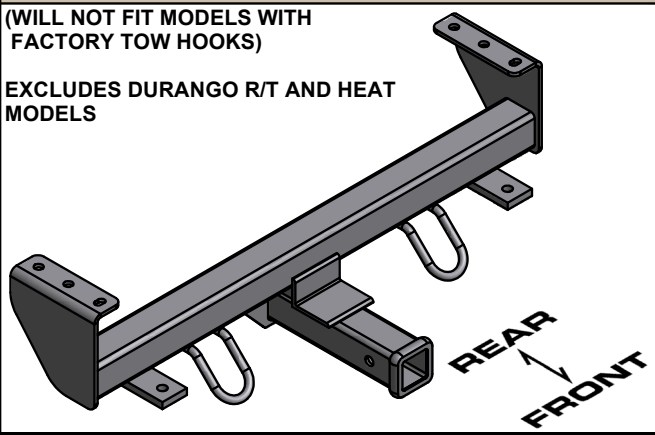

MAKE SURE YOUR HITCH MATCHES

PERIODICALLY CHECK THIS RECEIVER HITCH TO ENSURE ALL FASTENERS ARE TIGHT AND ALL STRUCTURAL COMPONENTS ARE SOUND

CURT Manufacturing LLC. warrants this product to be free of defects in material and/or workmanship at the time of retail purchase by the original purchaser. If the product is found to be defective, Curt Manufacturing LLC. may repair or replace the product at their option, when the product is returned, prepaid, with proof of purchase. Alteration to, misuse of, or improper installation of this product voids the warranty. Curt Manufacturing LLC.'s liability is limited to repair or replacement of products found to be defective, and specifically excludes liability for incidental or consequential loss or damage.

INSTALLATION WALKTHROUGH:

Parts List			
ITEM	QTY	PART NUMBER	DESCRIPTION
1	2	M10 - 1.5 x 35mm	HEX TAP BOLT
2	2	3/8"	CONICAL TOOTHED WASHER
3	6	1/2-13 x 1 1/2	CARRIAGE BOLT
4	6	CM-SP6	.250 x 1.00 x 3.00" SQUARE HOLE SPACER
5	6	HFN 1213	HEX FLANGE NUT
6	3	1_2 FISHWIRE	1/2" FISHWIRE

FISHWIRE TECHNIQUE

INSERT COILED END OF FISHWIRE TOOL THROUGH HITCH MOUNTING HOLE IN VEHICLE FRAME RAIL AND OUT THE ACCESS HOLE. PASS COILED END OF FISHWIRE THROUGH SPACER AND THREAD BOLT INTO COIL. KINK WIRE TO KEEP SPACER SEPERATE FROM BOLT AS SHOWN. PULL FISHWIRE, SPACER, AND BOLT THROUGH FRAME AND OUT MOUNTING HOLE. USE FISHWIRE TO GUIDE HITCH DURING MOUNTING AND PREVENT LOSS OF BOLT / SPACER INSIDE FRAME RAIL.

****NOTE: SOME VEHICLES MAY FISHWIRE THROUGH END OF FRAME****

TRIM DIAGRAM

NOTE: TRIM DIMENSIONS ARE APPROXIMATE CONFIRM FIT PRIOR TO TRIMMING

DETAIL A

REVERSE PULL FISHWIRE TECHNIQUE

ATTACH FISHWIRE TO CARRIAGE BOLT AND SLIDE SPACER ONTO FISHWIRE. PUSH THE BOLT THRU THE HOLE FOLLOWED BY THE SPACER (AS SHOWN). PULL BOLT BACK INTO POSITION, PROTRUDING FROM THE FRAME.

WELDNUT CLEANING

To remove debris from weldnuts in frame, spray lubricant or compressed air into hole. For heavy debris, use a small wire brush. (Be careful not to damage threads).

INSTALLATION WALKTHROUGH:

1. Remove plastic underbody panel by removing (7) bolts and (1) plastic fastener. This can be trimmed and reinstalled in step 8 or returned to vehicle owner.



2. Lift hitch into position, secure with M10 bolts and mark (4) drill hole locations.

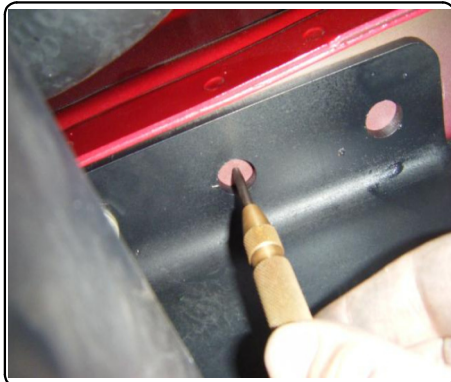

3. Remove M10 bolts, lower hitch and drill (4) holes at marked locations.

Note: Use a die grinder to enlarge (1) drilled hole on each frame rail so it is large enough for the included 1/2" hardware to pass through.

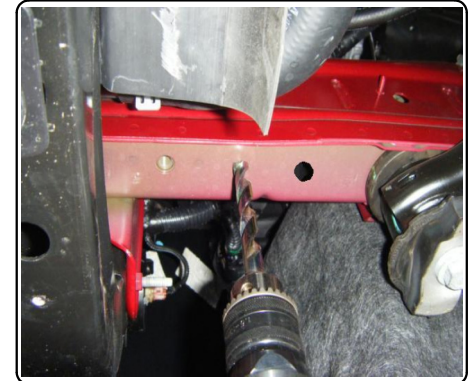
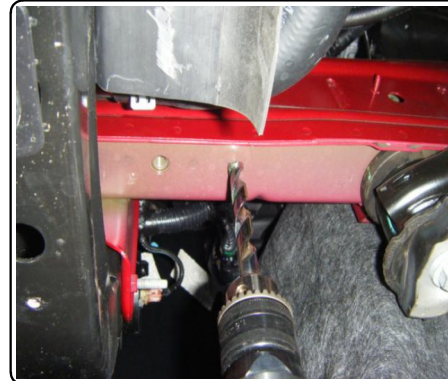

4. Use a die grinder to enlarge (2) mounting locations on vehicle cross member so the included 1/2" hardware can be reverse fishwired into position.

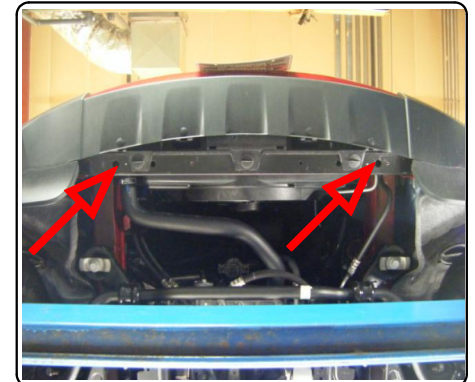

INSTALLATION WALKTHROUGH:

5. Fishwire (2) 1/2" carriage bolts and (2) CM-SP6 spacers into position. Reverse fishwire (4) 1/2" carriage bolts and (4) CM-SP6 spacers into position. See FISHWIRE TECHNIQUE / REVERSE PULL TECHNIQUE on page 2.



6. Raise hitch into position and secure to frame using 1/2" flange nuts. Secure (2) 10mm bolts and (2) 3/8" conical toothed washers into the existing weldnuts. See WELDNUT CLEANING on page 2.



7. Torque all 10mm hardware to 35 ft-lbs and all 1/2" hardware to 75 ft-lbs.



8. If plastic underbody panel will be trimmed see TRIM DIAGRAM on page 2. Reinstall after trimming is complete.

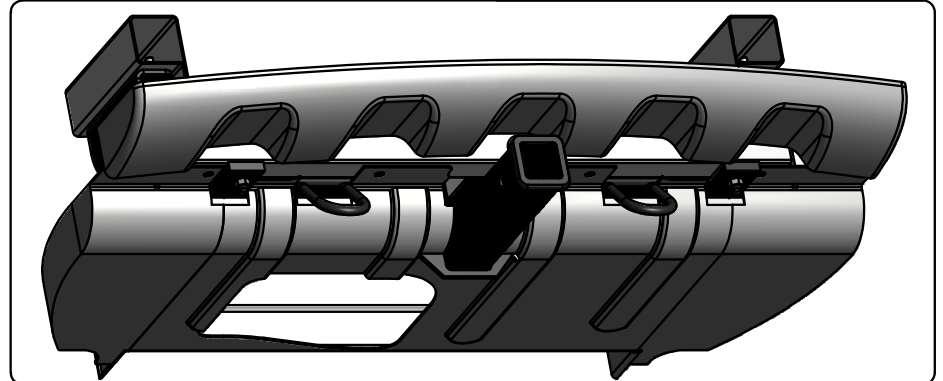

INSTALLATION WALKTHROUGH:

9. On Dodge Durango models, the lower fascia and bumper will need to be trimmed to provide clearance for the hitch receiver tube. See Dodge Durango Bumper Trim Diagram.

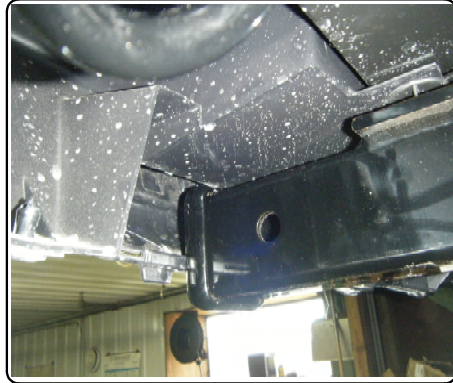
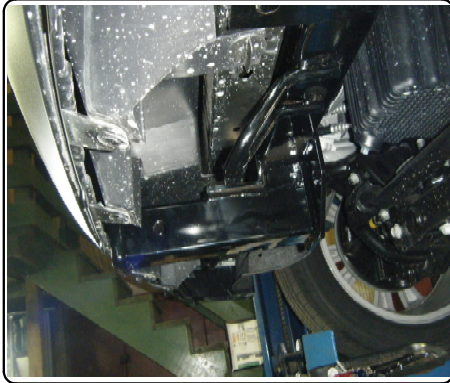

31033 JEEP GRAND CHEROKEE AND DODGE DURANGO

WILL NOT FIT MODELS WITH FACTORY TOW HOOKS, EXCLUDES DURANGO R/T AND HEAT MODELS

GROSS LOAD CAPACITY WHEN USED AS A WEIGHT CARRYING HITCH: 3,000 LBS. TRAILER WEIGHT & 300 LBS. TONGUE WEIGHT.

GROSS LOAD CAPACITY WHEN USED AS A STRAIGHT LINE PULL: 9,000 LBS. MAX. LINE PULL.

***** DO NOT EXCEED VEHICLE MANUFACTURER'S RECOMMENDED TOWING CAPACITY. *****

Parts List			
ITEM	QTY	PART NUMBER	DESCRIPTION
1	2	M10 - 1.5 x 35mm	HEX TAP BOLT
2	2	3/8"	CONICAL TOOTHED WASHER
3	6	1/2-13 x 1 1/2	CARRIAGE BOLT
4	6	CM-SP6	.250 x 1.00 x 3.00" SQUARE HOLE SPACER
5	6	HFN 1213	HEX FLANGE NUT
6	3	1_2 FISHWIRE	1/2" FISHWIRE

TOOLS REQUIRED
DRILL
9/16" DRILL BIT
DIE GRINDER
RATCHET
10mm, 13mm, 18mm & 3/4" SOCKET
TORQUE WRENCH
TAPE MEASURE
MARKER
UTILITY KNIFE

FISHWIRE TECHNIQUE

INSERT COILED END OF FISHWIRE TOOL THROUGH HITCH MOUNTING HOLE IN VEHICLE FRAME RAIL AND OUT THE ACCESS HOLE. PASS COILED END OF FISHWIRE THROUGH SPACER AND THREAD BOLT INTO COIL. KINK WIRE TO KEEP SPACER SEPARATE FROM BOLT AS SHOWN. PULL FISHWIRE, SPACER, AND BOLT THROUGH FRAME AND OUT MOUNTING HOLE. USE FISHWIRE TO GUIDE HITCH DURING MOUNTING AND PREVENT LOSS OF BOLT / SPACER INSIDE FRAME RAIL.

NOTE: SOME VEHICLES MAY FISHWIRE THROUGH END OF FRAME

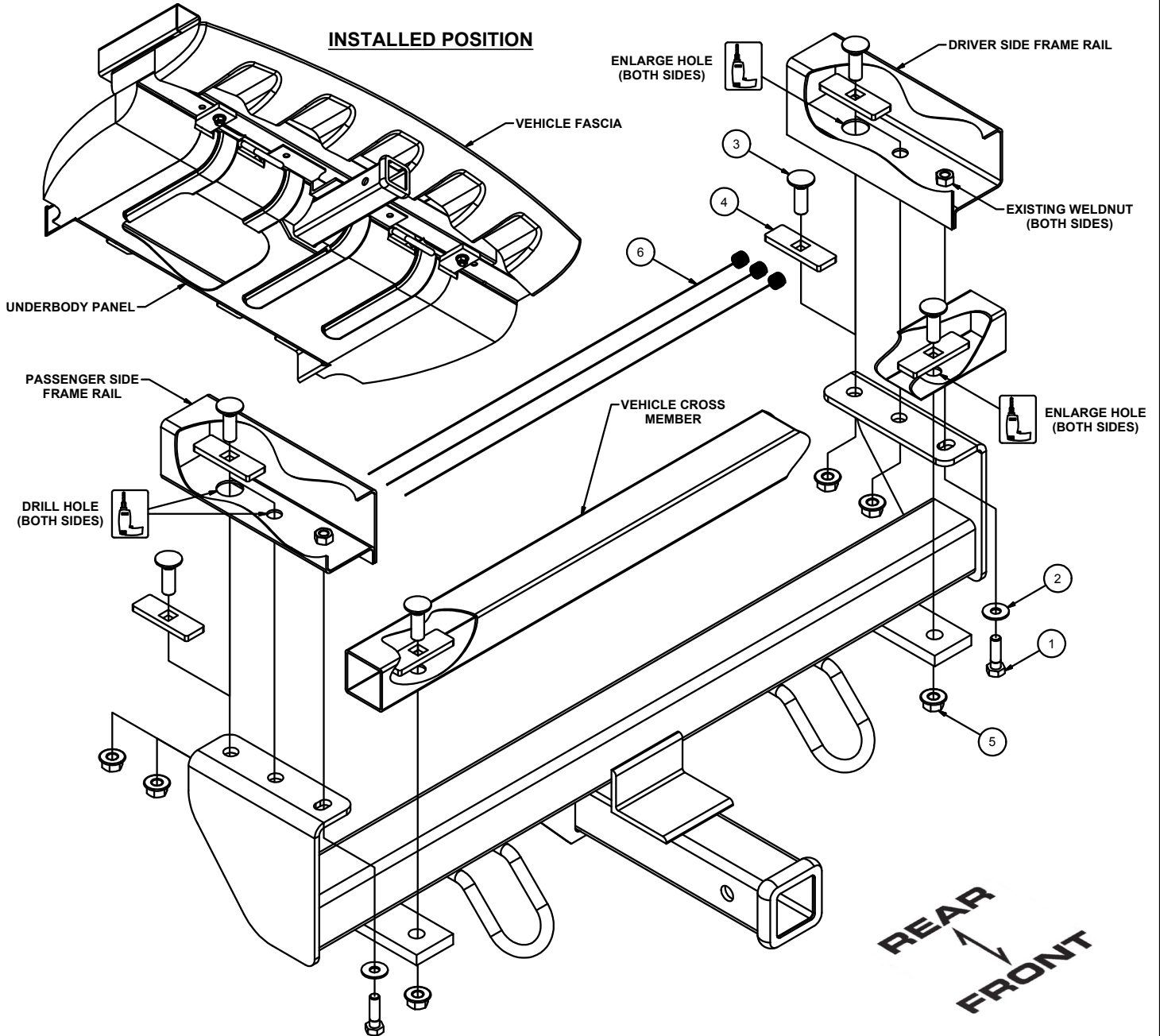

PERIODICALLY CHECK THIS RECEIVER HITCH TO ENSURE THAT ALL FASTENERS ARE TIGHT AND THAT ALL STRUCTURAL COMPONENTS ARE SOUND.

Curt Manufacturing Inc., warrants this product to be free of defects in material and/or workmanship at the time of retail purchase by the original purchaser. If the product is found to be defective, Curt Manufacturing Inc., may repair or replace the product, at their option, when the product is returned, prepaid, with proof of purchase. Alteration to, misuse of, or improper installation of this product voids the warranty. Curt Manufacturing Inc.'s liability is limited to repair or replacement of products found to be defective, and specifically excludes liability for incidental or consequential loss or damage.

31033 JEEP GRAND CHEROKEE AND DODGE DURANGO

WILL NOT FIT MODELS WITH FACTORY TOW HOOKS, EXCLUDES DURANGO R/T AND HEAT MODELS

GROSS LOAD CAPACITY WHEN USED AS A WEIGHT CARRYING HITCH: 3,000 LBS. TRAILER WEIGHT & 300 LBS. TONGUE WEIGHT.
GROSS LOAD CAPACITY WHEN USED AS A STRAIGHT LINE PULL: 9,000 LBS. MAX. LINE PULL.

***** DO NOT EXCEED VEHICLE MANUFACTURER'S RECOMMENDED TOWING CAPACITY. *****

TRIM DIAGRAM

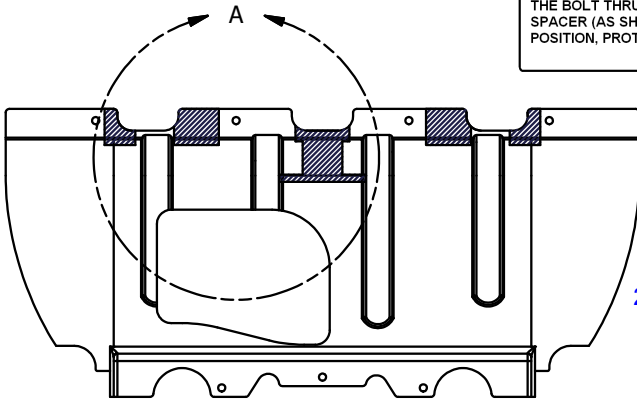

REVERSE PULL FISHWIRE TECHNIQUE

ATTACH FISHWIRE TO CARRIAGE BOLT AND SLIDE SPACER ONTO FISHWIRE. PUSH THE BOLT THRU THE HOLE FOLLOWED BY THE SPACER (AS SHOWN). PULL BOLT BACK INTO POSITION, PROTRUDING FROM THE FRAME.

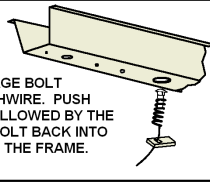

WELDNUT CLEANING

To remove debris from weldnuts in frame, spray lubricant or compressed air into hole. For heavy debris, use a small wire brush. (Be careful not to damage threads).

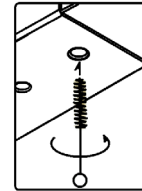

**NOTE: TRIM DIMENSIONS ARE APPROXIMATE
CONFIRM FIT PRIOR TO TRIMMING**

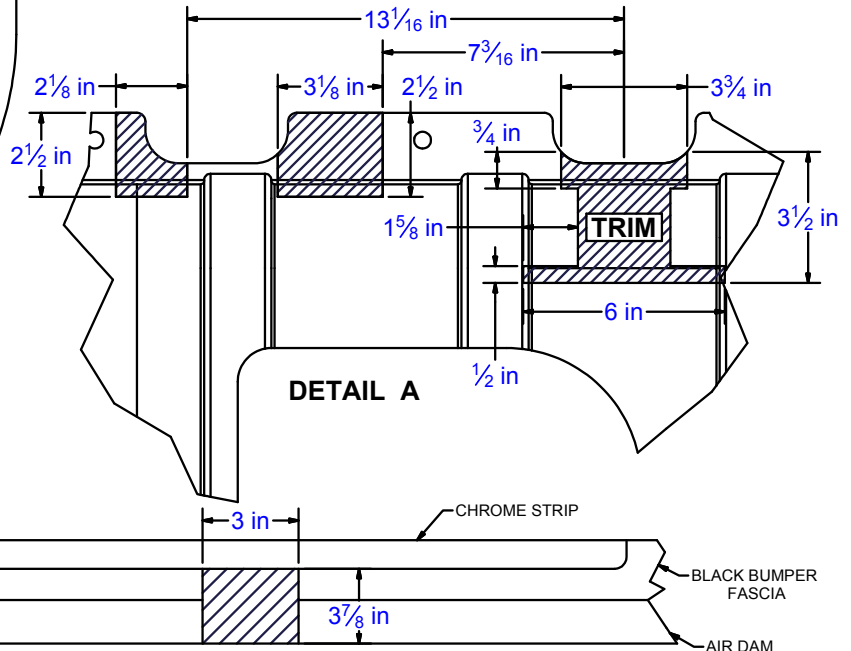

DODGE DURANGO BUMPER TRIM DIAGRAM

HITCH WEIGHT: 42 LBS.

INSTALL TIME

PROFESSIONAL: 35 MINUTES

NOVICE (DIY): 70 MINUTES

INSTALL NOTES:

- DRILLING REQUIRED
- ENLARGE HOLES
- FISHWIRE HARDWARE
- FASCIA TRIMMING

INSTALLATION STEPS

1. Remove plastic underbody panel by removing (7) bolts and (1) plastic fastener. This can be trimmed and reinstalled in step 8 or returned to vehicle owner.
2. Lift hitch into position, secure with M10 bolts and mark (4) drill hole locations.
3. Remove M10 bolts, lower hitch and drill (4) holes at marked locations. **Note:** Use a die grinder to enlarge (1) drilled hole on each frame rail so it is large enough for the included 1/2" hardware to pass through.
4. Use a die grinder to enlarge (2) mounting locations on vehicle cross member so the included 1/2" hardware can be reverse fishwired into position.
5. Fishwire (2) 1/2" carriage bolts and (2) CM-SP6 spacers into position. Reverse fishwire (4) 1/2" carriage bolts and (4) CM-SP6 spacers into position. See FISHWIRE TECHNIQUE / REVERSE PULL TECHNIQUE above.
6. Raise hitch into position and secure to frame using 1/2" flange nuts. Secure (2) 10mm bolts and (2) 3/8" conical toothed washers into the existing weldnuts. See WELDNUT CLEANING above.
7. Torque all 10mm hardware to 35 ft-lbs and all 1/2" hardware to 75 ft-lbs.
8. If plastic underbody panel will be trimmed see TRIM DIAGRAM above. Reinstall after trimming is complete.
9. On Dodge Durango models, the lower fascia and bumper will need to be trimmed to provide clearance for the hitch receiver tube. See Dodge Durango Bumper Trim Diagram.

**PERIODICALLY CHECK THIS RECEIVER HITCH TO ENSURE THAT ALL FASTENERS
ARE TIGHT AND THAT ALL STRUCTURAL COMPONENTS ARE SOUND.**

Curt Manufacturing Inc., warrants this product to be free of defects in material and/or workmanship at the time of retail purchase by the original purchaser. If the product is found to be defective, Curt Manufacturing Inc., may repair or replace the product, at their option, when the product is returned, prepaid, with proof of purchase. Alteration to, misuse of, or improper installation of this product voids the warranty. Curt Manufacturing Inc.'s liability is limited to repair or replacement of products found to be defective, and specifically excludes liability for incidental or consequential loss or damage.

31033 JEEP GRAND CHEROKEE AND DODGE DURANGO

*****DO NOT EXCEED VEHICLE MANUFACTURER'S RECOMMENDED TOWING CAPACITY*****.

FRONT MOUNTED ACCESSORIES

1) Do not exceed front axle Gross Weight Rating (GAWR). Consult owners manual or specification plate located on driver's door frame. Measure gross front axle weight by placing front wheels of loaded vehicle on a scale.

WARNING: Exceeding GAWR may overload the front axle and/or suspension. This could result in **accident, property damage and personal injury.**

- 2) Reposition front mounted license plate if obstructed.
- 3) Do not obstruct vehicle lights.
- 4) Allow free air flow into grille opening.
- 5) Rear wheel traction may be reduced. This could effect handling. Reduce speed and drive with caution.
- 6) Accessories extend front of vehicle. This may reduce approach angle. Use caution when parking and maneuvering.
- 7) Do not obstruct driver view.

VEHICLE RECOVERY AND WINCHING TIPS

1) Use OEM tow hooks, recovery eyes or a clevis mount for attachment of a tow strap or winch cable.

WARNING: NEVER use a ball and/or ball mount as an anchor point for tow strap or winch cable. Severe personal injury or death could result.

- 2) Observe winch manufacturer's recommendations, cautions and warnings.
- 3) Attach return cable to tow hook or recovery eye when using a snatch block (See figure 1).

CAUTION: Do not attach return cable to winch mount. This may overload winch mount and/or front mounted receiver.

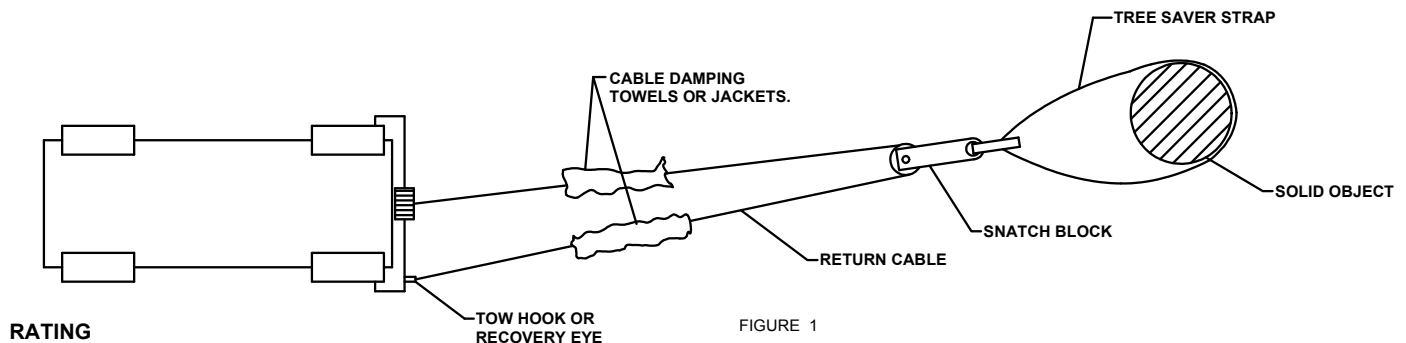

For **Maximum** line pull rating, winch cable must not exceed:
- 15 degree angle up or down from horizontal (See Figure 2).
- 45 degree angle left or right from straight ahead (See Figure 3).

CAUTION: Exceeding the maximum line pull rating may over load winch, winch mount, and/or front mounted receiver.

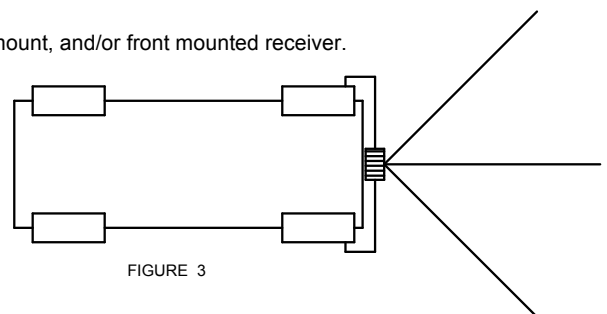
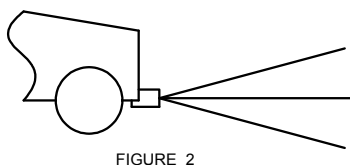

Curt Manufacturing Inc., warrants this product to be free of defects in material and/or workmanship at the time of retail purchase by the original purchaser. If the product is found to be defective, Curt Manufacturing Inc., may repair or replace the product, at their option, when the product is returned, prepaid, with proof of purchase. Alteration to, misuse of, or improper installation of this product voids the warranty. Curt Manufacturing Inc.'s liability is limited to repair or replacement of products found to be defective, and specifically excludes liability for incidental or consequential loss or damage.

Looking for dependable trailer hitches and towing? Rely on CURT for quality and long-lasting products.