

# 31017 DODGE RAM 2500 & 3500 (EXCEPT 3500 LARAMIE)

GROSS LOAD CAPACITY WHEN USED AS A WEIGHT CARRYING HITCH: 3,500 LBS. TRAILER WEIGHT & 350 LBS. TONGUE WEIGHT.  
 GROSS LOAD CAPACITY WHEN USED AS A STRAIGHT LINE PULL: 9,000 LBS. MAX. LINE PULL.  
**\*\*\* DO NOT EXCEED VEHICLE MANUFACTURER'S RECOMMENDED TOWING CAPACITY. \*\*\***

Parts List				
ITEM	QTY	PART NUMBER	DESCRIPTION	
1	2	1/2-13 x 1 1/2	CARRIAGE BOLT	
2	1	1/2"	FISHWIRE TOOL	
3	2	CM-SP40	.188 x 1.00 x 3.00" SQUARE HOLE SPACER	
4	2	HFN 1213	HEX FLANGE NUT	
5	2	CM-SP42	.250 x 2.00 x 2.00" ROUND HOLE SPACER	

**FISHWIRE TECHNIQUE**  
 INSERT COILED END OF FISHWIRE TOOL THROUGH HITCH MOUNTING HOLE IN VEHICLE FRAME RAIL AND OUT THE ACCESS HOLE. PASS COILED END OF FISHWIRE THROUGH SPACER AND THREAD BOLT INTO COIL. KINK WIRE TO KEEP SPACER SEPARATE FROM BOLT AS SHOWN. PULL FISHWIRE, SPACER, AND BOLT THROUGH FRAME AND OUT MOUNTING HOLE. USE FISHWIRE TO GUIDE HITCH DURING MOUNTING AND PREVENT LOSS OF BOLT / SPACER INSIDE FRAME RAIL.  
\*\*NOTE: SOME VEHICLES MAY FISHWIRE THROUGH END OF FRAME\*\*

**REVERSE PULL FISHWIRE TECHNIQUE**  
 ATTACH FISHWIRE TO CARRIAGE BOLT AND SLIDE SPACER ONTO FISHWIRE. PUSH THE BOLT THRU THE HOLE FOLLOWED BY THE SPACER (AS SHOWN). PULL BOLT BACK INTO POSITION, PROTRUDING FROM THE FRAME.

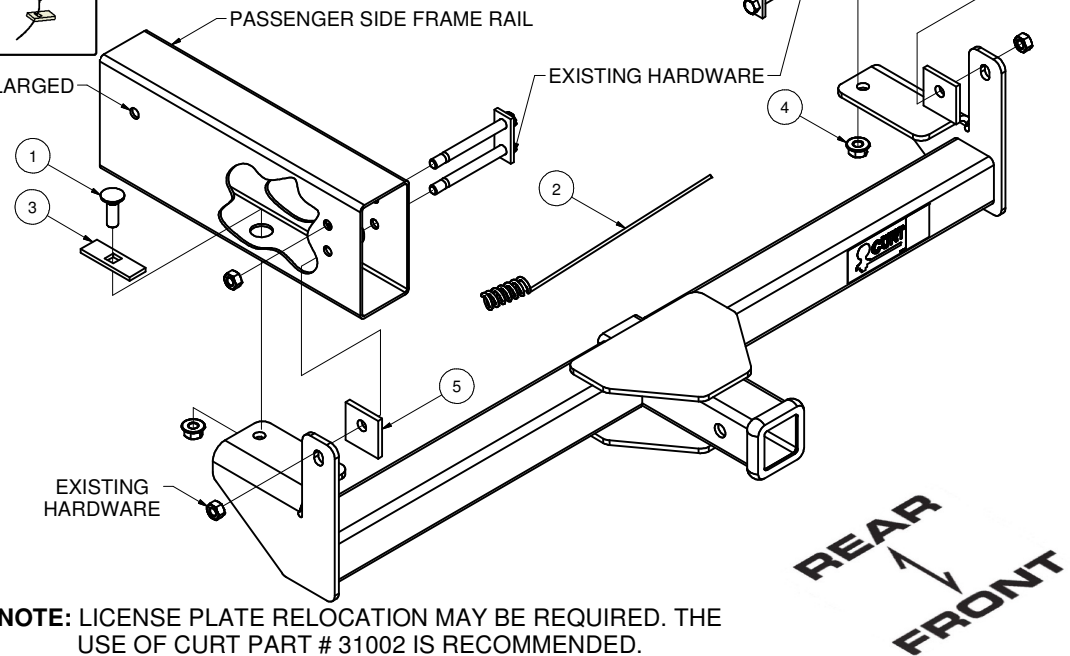
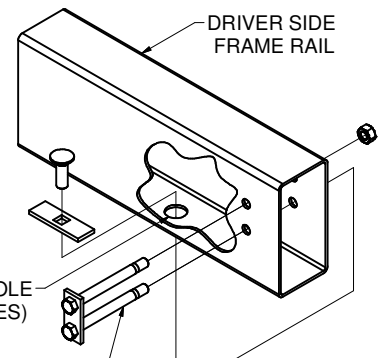

TOOLS REQUIRED
RATCHET
3/4 in & 18 mm SOCKETS
JACKSTANDS
1 1/8 in Ø HOLE SAW OR
5/16 in DRILL BIT & DIE GRINDER
TORQUE WRENCH

HITCH WEIGHT: 38 LBS.  
 INSTALL TIME  
 PROFESSIONAL: 30 MINUTES  
 NOVICE (DIY): 60 MINUTES  
 INSTALL NOTES:  
 -DRILLING REQUIRED  
 -FISHWIRE FASTENERS  
 -TRIMMING MAY BE REQUIRED

**NOTE: LICENSE PLATE RELOCATION MAY BE REQUIRED. THE USE OF CURT PART # 31002 IS RECOMMENDED.**

## INSTALLATION STEPS

- 1) Support front bumper with jackstands or similar to prevent bumper from falling during installation.
- 2) Remove hex nuts from existing bumper bolts that attach bumper mounting brackets to frame.
- 3) Install spacers over lower bumper bolts, lift hitch into position and reinstall nuts removed in STEP 2.
- 4) Using holes in hitch flanges as a template, mark and center punch the underside of the frame.
- 5) Remove hitch from vehicle.
- 6) Using a 1 1/8" diameter hole saw, drill holes in underside of frame at positions marked in STEP 4.  
**Note:** Some models have an access hole that can be enlarged with a die grinder, see above. If this is done drill a 9/16" hole at positions marked in STEP 4.
- 7) Fishwire carriage bolts and spacers through drilled hole or enlarged access hole from STEP 6. (See FISHWIRE TECHNIQUE above.)
- 8) Raise hitch into position and secure with flange nuts as shown.
- 9) Install spacers and existing bumper bolts as shown and secure with existing nuts.
- 10) Torque all fasteners to 75 lb-ft.

**PERIODICALLY CHECK THIS RECEIVER HITCH TO ENSURE THAT ALL FASTENERS ARE TIGHT AND THAT ALL STRUCTURAL COMPONENTS ARE SOUND.**

Curt Manufacturing Inc., warrants this product to be free of defects in material and/or workmanship at the time of retail purchase by the original purchaser. If the product is found to be defective, Curt Manufacturing Inc., may repair or replace the product, at their option, when the product is returned, prepaid, with proof of purchase. Alteration to, misuse of, or improper installation of this product voids the warranty. Curt Manufacturing Inc.'s liability is limited to repair or replacement of products found to be defective, and specifically excludes liability for incidental or consequential loss or damage.

\*\*\***DO NOT EXCEED VEHICLE MANUFACTURER'S RECOMMENDED TOWING CAPACITY**\*\*\*.

#### FRONT MOUNTED ACCESSORIES

1) Do not exceed front axle Gross Weight Rating (GAWR). Consult owners manual or specification plate located on driver's door frame. Measure gross front axle weight by placing front wheels of loaded vehicle on a scale.

**WARNING:** Exceeding GAWR may overload the front axle and/or suspension. This could result in **accident, property damage and personal injury.**

2) Reposition front mounted license plate if obstructed.

3) Do not obstruct vehicle lights.

4) Allow free air flow into grille opening.

5) Rear wheel traction may be reduced. This could effect handling. Reduce speed and drive with caution.

6) Accessories extend front of vehicle. This may reduce approach angle. Use caution when parking and maneuvering.

7) Do not obstruct driver view.

#### VEHICLE RECOVERY AND WINCHING TIPS

1) Use OEM tow hooks, recovery eyes or a clevis mount for attachment of a tow strap or winch cable.

**WARNING: NEVER** use a ball and/or ball mount as an anchor point for tow strap or winch cable. Severe personal injury or death could result.

2) Observe winch manufacturer's recommendations, cautions and warnings.

3) Attach return cable to tow hook or recovery eye when using a snatch block (See figure 1).

**CAUTION:** Do not attach return cable to winch mount. This may overload winch mount and/or front mounted receiver.

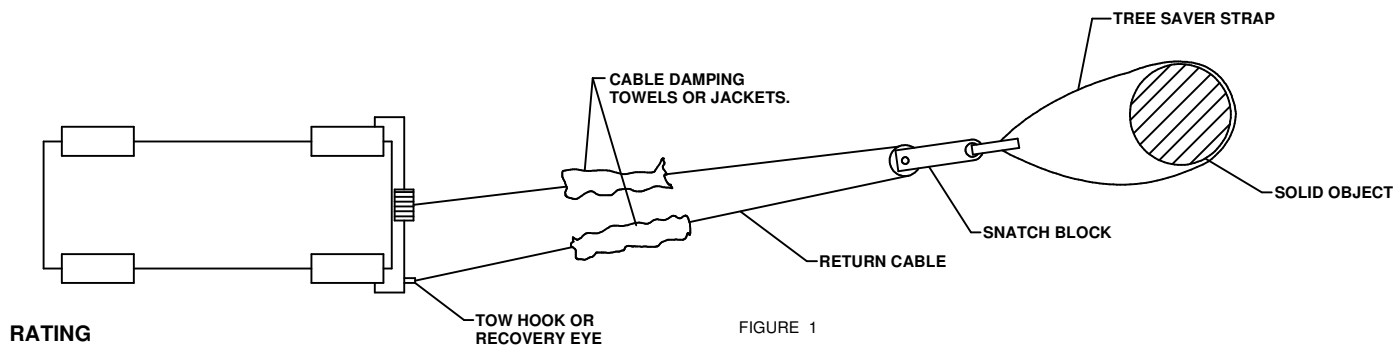

#### RATING

For **Maximum** line pull rating, winch cable must not exceed:

- 15 degree angle up or down from horizontal (See Figure 2).
- 45 degree angle left or right from straight ahead (See Figure 3).

**CAUTION:** Exceeding the maximum line pull rating may over load winch, winch mount, and/or front mounted receiver.

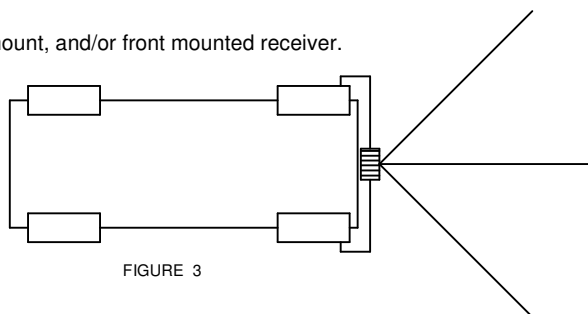
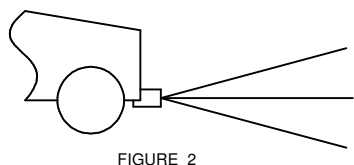

Curt Manufacturing Inc., warrants this product to be free of defects in material and/or workmanship at the time of retail purchase by the original purchaser. If the product is found to be defective, Curt Manufacturing Inc., may repair or replace the product, at their option, when the product is returned, prepaid, with proof of purchase. Alteration to, misuse of, or improper installation of this product voids the warranty. Curt Manufacturing Inc.'s liability is limited to repair or replacement of products found to be defective, and specifically excludes liability for incidental or consequential loss or damage.