

E-3S / E-3WS

GROSS LOAD CAPACITY WHEN USED AS A WEIGHT CARRYING HITCH: 5,000 LBS. TRAILER WEIGHT & 500 LBS. TONGUE WEIGHT.
*****DO NOT EXCEED VEHICLE MANUFACTURER'S RECOMMENDED TOWING CAPACITY.*****

Parts List			
ITEM	QTY	PART NUMBER	DESCRIPTION
1	2	3_4 - 10 x 3 HEX	HEX HEAD BOLT-NC
2	2	3_4 - 10 HFN	HEX FLANGE NUT
3	2	1/2-13 x 2"	HEX BOLT
4	2	HFN 1213	HEX FLANGE NUT
5	2	CM-SP15	.250 x 1.50 x 1.50" SPACER

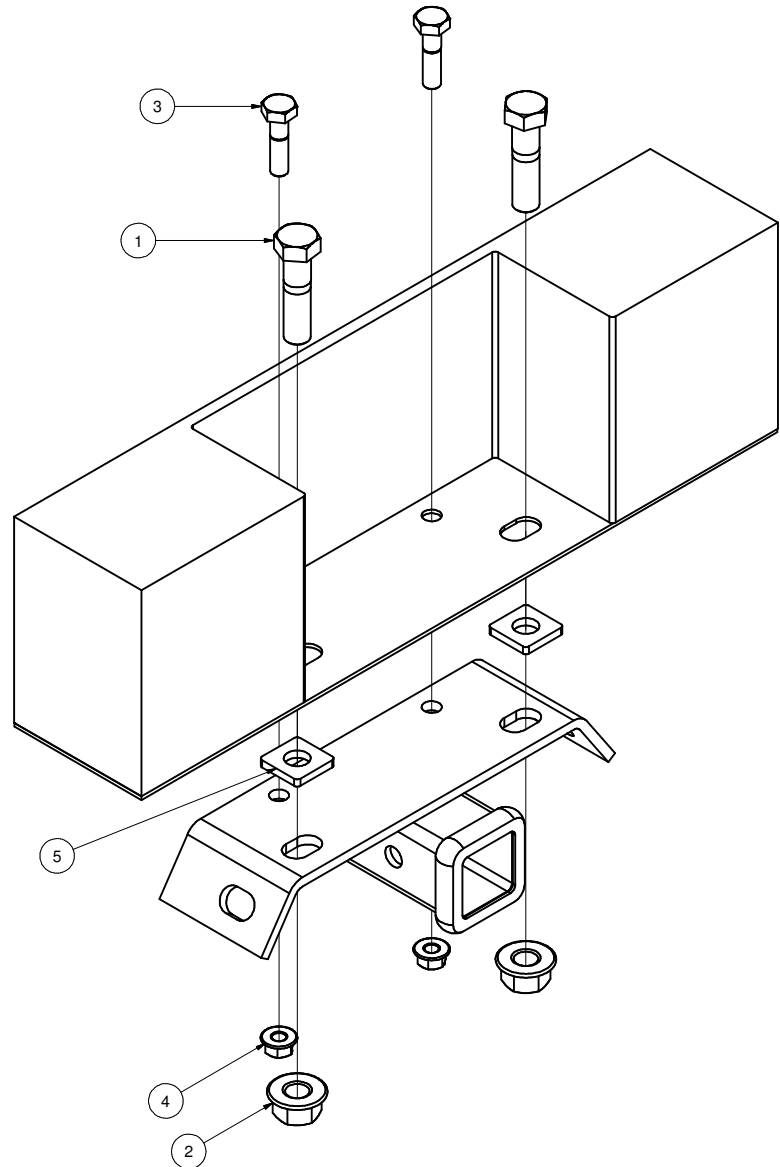

HITCH WEIGHT: 9 LBS.

INSTALL TIME: 10 MINUTES

INSTALL NOTES:

INSTALLATION STEPS

- 1) Position CURT Hitch to the underside of the original vehicle step plate.
- 2) Use existing holes if present. If existing holes can not be used, mark and drill holes for two 3/4" bolts and two 1/2" bolts.
- 3) Assemble using (A) 3/4" X 3 bolts and flange nuts (a) 1/2" X 2 bolts and flange nuts.
- 4) Spacers for 3/4" bolts (B) are provided. Use these spacers only if there is a welded tab on the underside of your bumper. It is very important to TIGHTEN NUTS SECURELY!

PERIODICALLY CHECK THIS RECEIVER HITCH TO ENSURE THAT ALL FASTENERS ARE TIGHT AND THAT ALL STRUCTURAL COMPONENTS ARE SOUND.

Curt Manufacturing Inc., warrants this product to be free of defects in material and/or workmanship at the time of retail purchase by the original purchaser. If the product is found to be defective, Curt Manufacturing Inc., may repair or replace the product, at their option, when the product is returned, prepaid, with proof of purchase. Alteration to, misuse of, or improper installation of this product voids the warranty. Curt Manufacturing Inc.'s liability is limited to repair or replacement of products found to be defective, and specifically excludes liability for incidental or consequential loss or damage.

Looking for dependable trailer hitches and towing? Rely on CURT for quality and long-lasting products.