

Parts List			
ITEM	QTY	PART NUMBER	DESCRIPTION
1	1	1/2"	FISHWIRE TOOL
2	8	CM-SP6	.250 x 1.00 x 3.00" SQUARE HOLE SPACER
3	18	1/2-13	HEX NUT
4	18	1/2"	LOCK WASHER
5	10	CM-SP136	.313" x 1.00 x 2.00" U-SHAPE SPACER
6	10	FW12	FW, 12, ZP
7	10	1/2 - 13 x 2"	CARRIAGE BOLT
8	2	M12	FLAT WASHER SPECIAL
9	2	1/2"	FLAT WASHER SPECIAL
10	8	1/2-13 x 1 1/2	CARRIAGE BOLT
11	2	CM-16300-PS	.375" PASSENGER SIDE PLATE
12	2	CM-16300-DS	.375" DRIVER SIDE PLATE

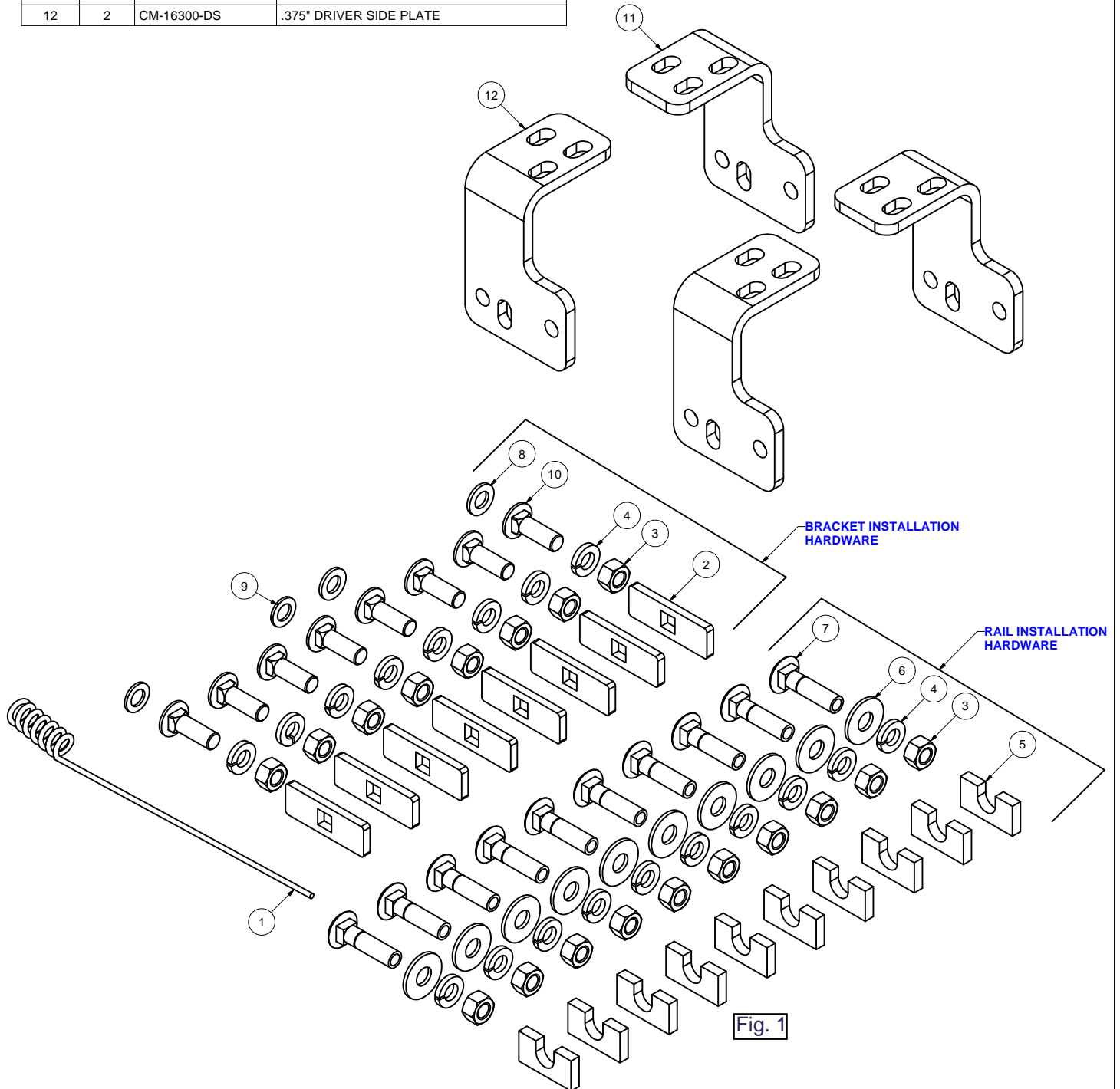

Fig. 1

Curt Manufacturing Inc., warrants this product to be free of defects in material and/or workmanship at the time of retail purchase by the original purchaser. If the product is found to be defective, Curt Manufacturing Inc., may repair or replace the product, at their option, when the product is returned, prepaid, with proof of purchase. Alteration to, misuse of, or improper installation of this product voids the warranty. Curt Manufacturing Inc.'s liability is limited to repair or replacement of products found to be defective, and specifically excludes liability for incidental or consequential loss or damage.

GENERAL INSTRUCTIONS FOR MOUNTING RAIL INSTALLATION

TOOLS

3/16" drill	3/4" Socket & Open End Wrench
17/32" drill	100 lb-ft Torque Wrench
1" drill (Some Dodge application only)	"C" Clamps

1. The following instructions should be used to mount the 5th wheel. Care and attention to detail will ensure a quality installation. Check parts against parts list to become familiar with parts in kit. (See Fig. 1)
2. Raise rear of truck high enough to allow jack stands to be placed under rear spring hanger bracket of truck. This will provide maximum room to install the 5th wheel brackets.



WARNING:

If the truck is raised, be sure that the truck is properly blocked and restrained to prevent the truck from falling. Failure to do so may result in the truck suddenly falling, causing death or serious injury.

3. Do not install mounting rails over plastic bed liners. Plastic bed liners must be cut out of the way. Mounting rails may be installed on spray in liner. **Note:** Consult installer for recommended curing time.
4. Use only the supplied bolts, nuts, and washers to install this kit. All installation hardware is grade 5 unless otherwise specified.
5. Specific instructions for most commonly used vehicles are included. If these instructions do not apply to your vehicle, be sure that each end of each base rail is connected to the vehicle frame. Each frame bracket must be bolted to the vehicle frame with two bolts, unless optional weld is used.



CAUTION:



These instructions are guidelines only. Actual installation is the responsibility of the installer and the owner. Always measure truck and trailer before installing hitch to be sure that there is clearance at the cab and at the bumper to allow for turns.

To prevent the trailer from hitting the cab with the trailer turned 90°, the center of the hitch should be at least 52" from the back of the cab when using a long bed truck. (Actual distance required will depend on trailer width and king pin location.) Short bed (Minimum 38" from back cab to axle center line) trucks require a minimum of a 13" extended pin box for regular maneuvers and do not apply.

6. Measurements are given from Rear Edge of truck bed to rear edge of the mounting rail closest to the Rear Edge of truck for most vehicle applications (See Fig. 2).

7. Center hitch between fender wells and make sure rails are square. Adjust position of rails until both diagonal measurements are the same. This should allow installation of a gooseneck or other 5th wheels to these rails (See Fig. 2).



CAUTION:



Check for obstructions before drilling. Failure to do so could result in damaged fuel or brake lines, structural members, etc. CURT MANUFACTURING does its best to communicate tow vehicle manufacturer changes; however, it is ultimately the responsibility of the installer to prevent damage due to installation.

8. Drill 10 holes identified in Fig. 2. (Hole location will vary for individual vehicle applications.) Drill all holes with 3/16" drill and enlarge them with a 17/32" drill. Always use sharp drill bits. A 3/16" pilot hole will greatly speed drilling larger holes. Install 1/2-13 x 2" carriage bolts into holes. Install 5/16" thick slotted spacer above or below bed to fill corrugations in bed floor. **NOTE: For Toyota Tundra application, part #16302 spacer kit is required. Stack (1) 3/16" and (1) 5/16" thick slotted spacer to avoid crushing of truck bed.**

9. Install mounting brackets onto carriage bolts. Secure bolts through mounting brackets with lock washers and hex nuts. Secure the other four bolts through the bed with flat washers, lock washers, and nuts.

10. Drill two holes in frame for each bracket. Select the holes which will give the greatest spread between bolts. Install eight 1/2"-13x1-1/2" carriage bolts and spacers.

Note: On vehicles with heavy duty suspensions, check for interference with bolts where brackets are mounted to frame. If interference with suspension spring results, cut bolt flush to nut outboard of frame or use weld option.

 **WARNING:**
DO NOT lubricate threads. It may cause bolt failure.

 **CAUTION:** 
Check for obstructions before drilling. Failure to do so could result in damaged fuel or brake lines, structural members, etc. CURT MANUFACTURING does its best to communicate tow vehicle manufacturer changes; however, it is ultimately the responsibility of the installer to prevent damage due to installation.

11. Torque all nuts to 85 lb-ft

12. Pull wire provided to pull rib neck bolts through frame as needed per application

Drill locations will vary. See individual installation for location

Use mounting channel/cross member assembly to position rails (not included).

**** Diagonal Measurements must be the same for smooth Operation of 16500 rolling units ****

Fig. 2

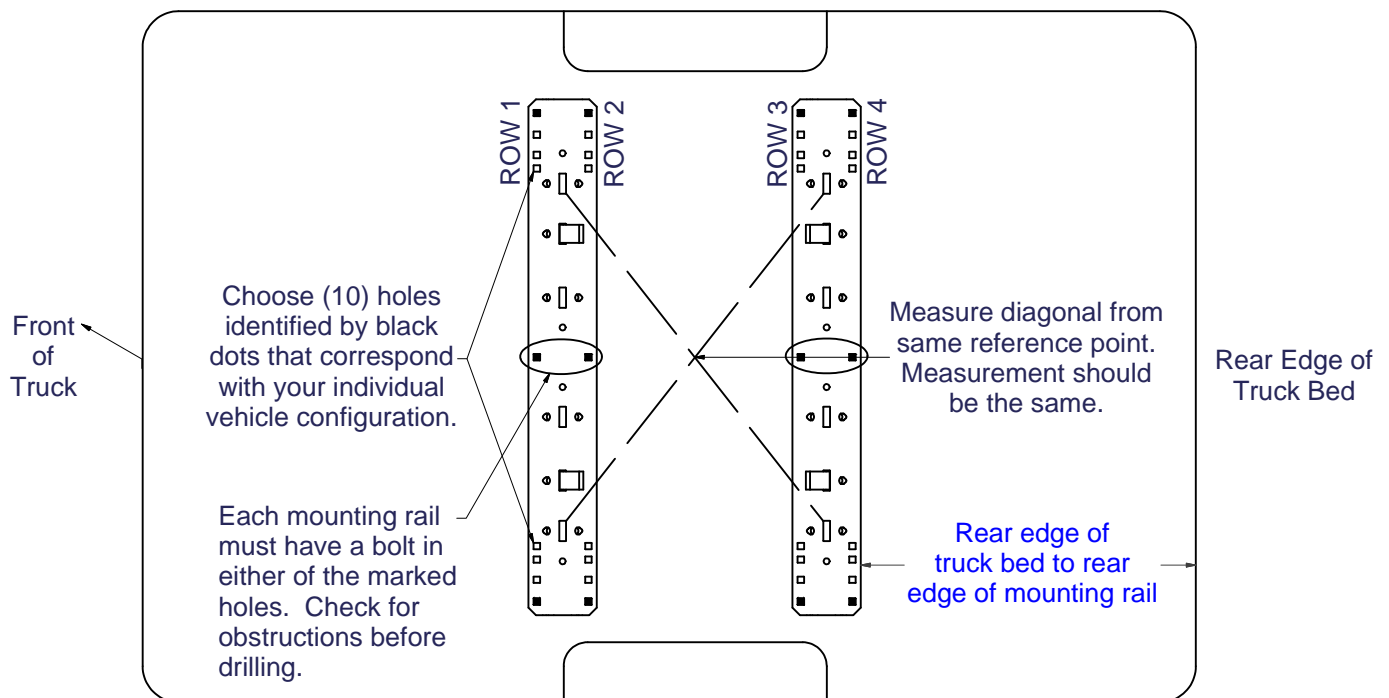

CAUTION!

READ INSTRUCTIONS OF RAIL SYSTEM BEFORE STARTING INSTALLATION. FAILURE TO DO SO COULD RESULT IN SIGNIFICANT VEHICLE DAMAGE!

IMPORTANT NOTES FOR THIS INSTALLATION:

1. Do not drill through both walls of frame. Drill only through wall of frame to which bracket is mounted.
2. Find parallel rows of bed sill spot welds in bed of truck. No drilling should be done in the 4" between parallel rows of spot welds where the bed sill sits.
3. Remove jounce block from bottom of frame on both sides.
4. When brackets are in place one of the front 2 holes should line up with a hole in the frame. A hole will need to be drilled in the frame at the rearward bracket hole.
5. Pull carriage bolts with bolt plates (using supplied pull wire) through the hole in the bottom of frame (where the jounce block was removed) and through the rear hole in each bracket. On the forward brackets, a carriage bolt, bolt plate and a 1" washer should be pulled through the forward hole. Rearward brackets should have a carriage bolt, bolt plate and 13/16" washer pulled through.
6. Replace the jounce block.

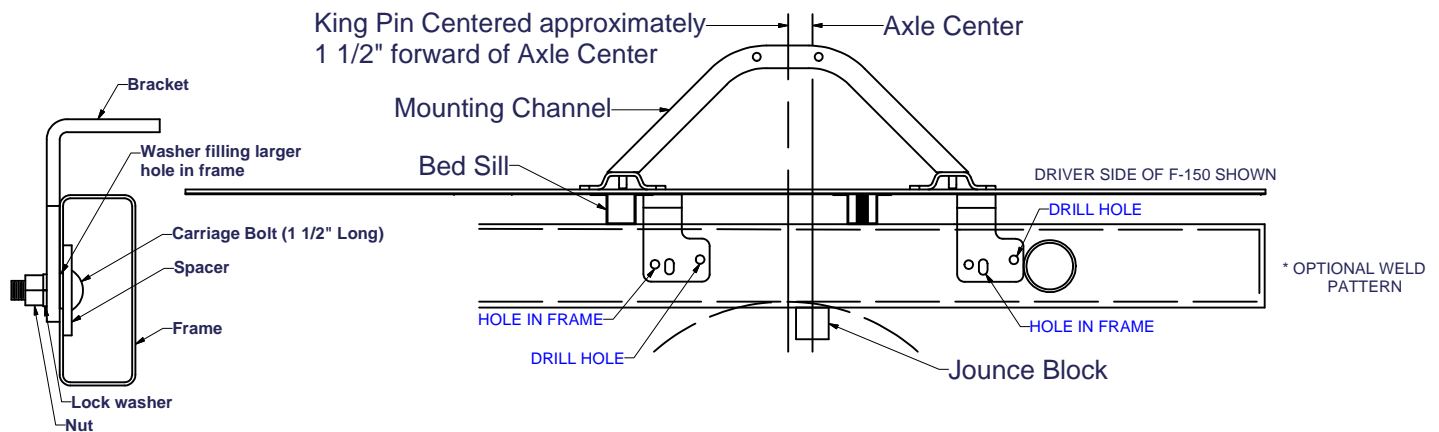
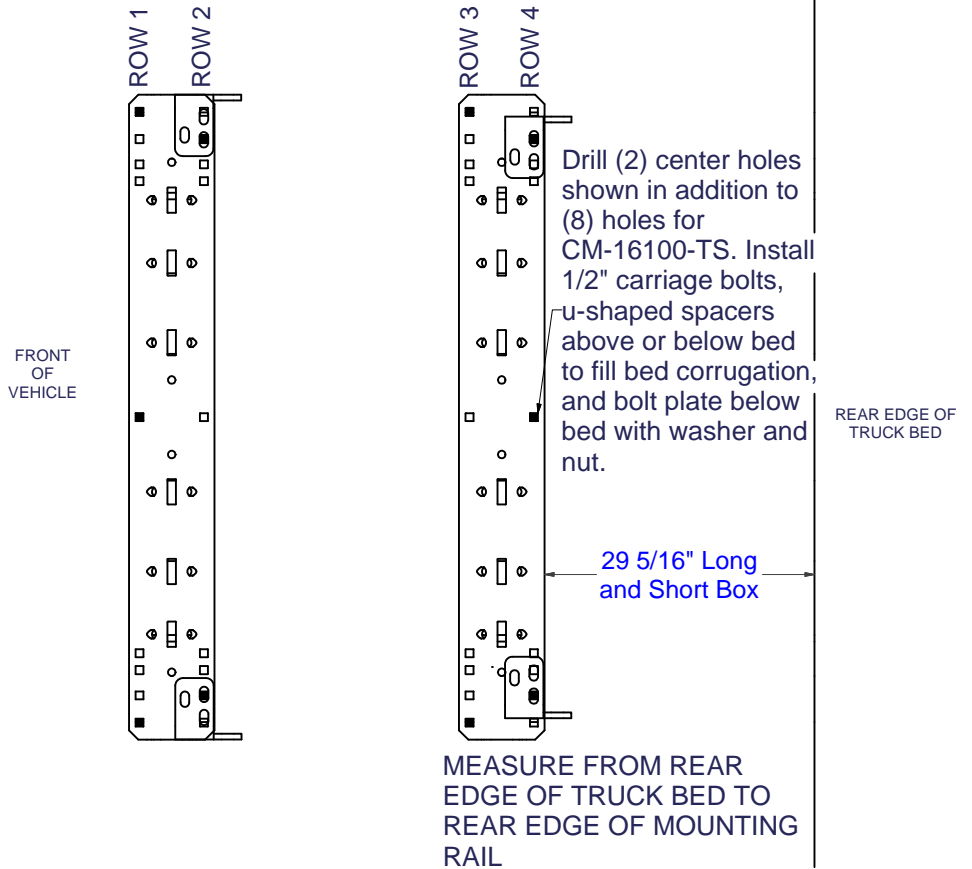

CAUTION!

CHECK FOR OBSTRUCTIONS BEFORE DRILLING. FAILURE TO DO SO COULD RESULT IN DAMAGED FUEL OR BRAKE LINES, STRUCTURAL MEMBERS, ETC. CURT MANUFACTURING DOES ITS BEST TO COMMUNICATE TOW VEHICLE MANUFACTURER CHANGES; HOWEVER, IT IS ULTIMATELY THE RESPONSIBILITY OF THE INSTALLER TO PREVENT DAMAGE DUE TO INSTALLATION.