

14081 / RRH14081

1988 - 2000 CHEVY/GMC ALL FULL SIZE W/DUAL EXHAUST (OLD STYLE)
1988 - 1998 CHEVY/GMC 1500 TON W/6' & 8' BED (OLD STYLE)
1988 - 2000 CHEVY/GMC 3/4 & 1 TON CLASSIC, 6' & 8' BED (OLD STYLE)
1992 - 1998 CHEVY/GMC 4 DR CREW CAB ONLY

GROSS LOAD CAPACITY WHEN USED AS A WEIGHT CARRYING HITCH: 10,000 LBS. TRAILER WEIGHT & 1,000 LBS. TONGUE WEIGHT.
GROSS LOAD CAPACITY WHEN USED AS A WEIGHT DISTRIBUTION HITCH: 12,000 LBS. TRAILER WEIGHT & 1,200 LBS. TONGUE WEIGHT

*****DO NOT EXCEED VEHICLE MANUFACTURER'S RECOMMENDED TOWING CAPACITY.*****

Parts List			
ITEM	QTY	PART NUMBER	DESCRIPTION
1	4	1/2 - 13 x 2"	CARRIAGE BOLT
2	6	CM-SP1	.250 x 1.50 x 2.00" SQUARE HOLE SPACER
3	4	HFN 1213	HEX FLANGE NUT
4	2	1/2"	CONICAL TOOTHED WASHER
5	2	M12 - 1.75 x 50mm	HEX BOLT
6	2	M12 - 1.75	HEX NUT

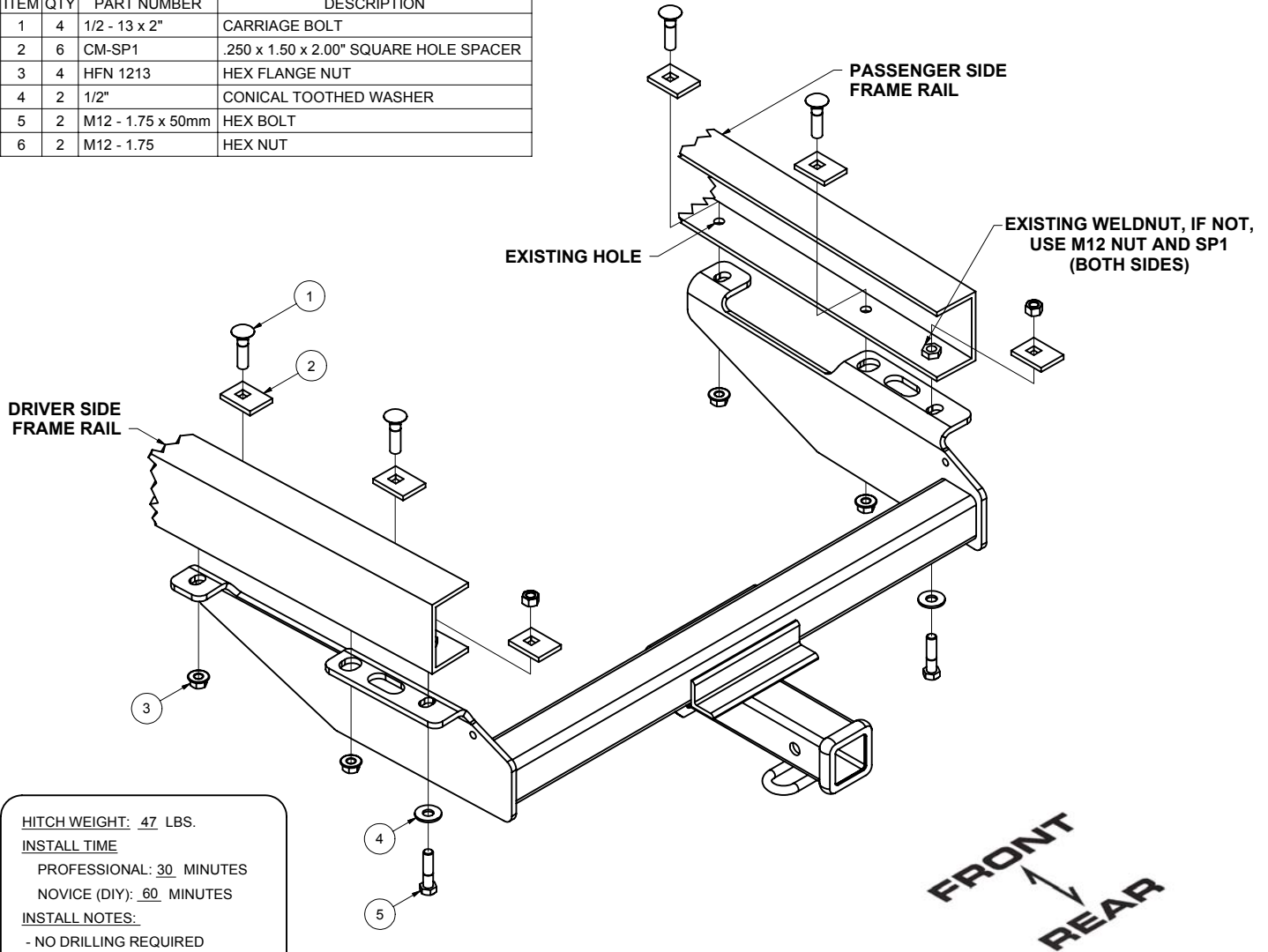

HITCH WEIGHT: 47 LBS.

INSTALL TIME

PROFESSIONAL: 30 MINUTES

NOVICE (DIY): 60 MINUTES

INSTALL NOTES:

- NO DRILLING REQUIRED

- LOWER SPARE TIRE

INSTALLATION STEPS

1. Lower the spare tire. The rear bolt in the bottom of the frame on each side must be removed, if equipped with factory step bumper. Clean away any undercoating present.
2. Using the hardware provided, fasten hitch to frame as shown.
3. Reposition the spare tire slightly forward to clear the receiver hitch. Oversize spare tire may have to be relocated.
4. Torque all 1/2" fasteners to 75 ft-lbs. and all M12 bolts to 59 ft-lbs.

PERIODICALLY CHECK THIS RECEIVER HITCH TO ENSURE THAT ALL FASTENERS ARE TIGHT AND THAT ALL STRUCTURAL COMPONENTS ARE SOUND.

Curt Manufacturing Inc., warrants this product to be free of defects in material and/or workmanship at the time of retail purchase by the original purchaser. If the product is found to be defective, Curt Manufacturing Inc., may repair or replace the product, at their option, when the product is returned, prepaid, with proof of purchase. Alteration to, misuse of, or improper installation of this product voids the warranty. Curt Manufacturing Inc.'s liability is limited to repair or replacement of products found to be defective, and specifically excludes liability for incidental or consequential loss or damage.

Looking for dependable trailer hitches and towing? Rely on CURT for quality and long-lasting products.