

13594**SATURN VUE, ALL INC. REDLINE**

GROSS LOAD CAPACITY WHEN USED AS A WEIGHT CARRYING HITCH: 3,500 LBS. TRAILER WEIGHT & 350 LBS. TONGUE WEIGHT.
 GROSS LOAD CAPACITY WHEN USED AS A WEIGHT DISTRIBUTION HITCH: 4,000 LBS. TRAILER WEIGHT & 400 LBS. TONGUE WEIGHT

*****DO NOT EXCEED VEHICLE MANUFACTURER'S RECOMMENDED TOWING CAPACITY.*****

Parts List			
ITEM	QTY	PART NUMBER	DESCRIPTION
1	6	M12-1.75 x 35mm	HEX BOLT
2	6	1/2"	CONICAL TOOTHED WASHER

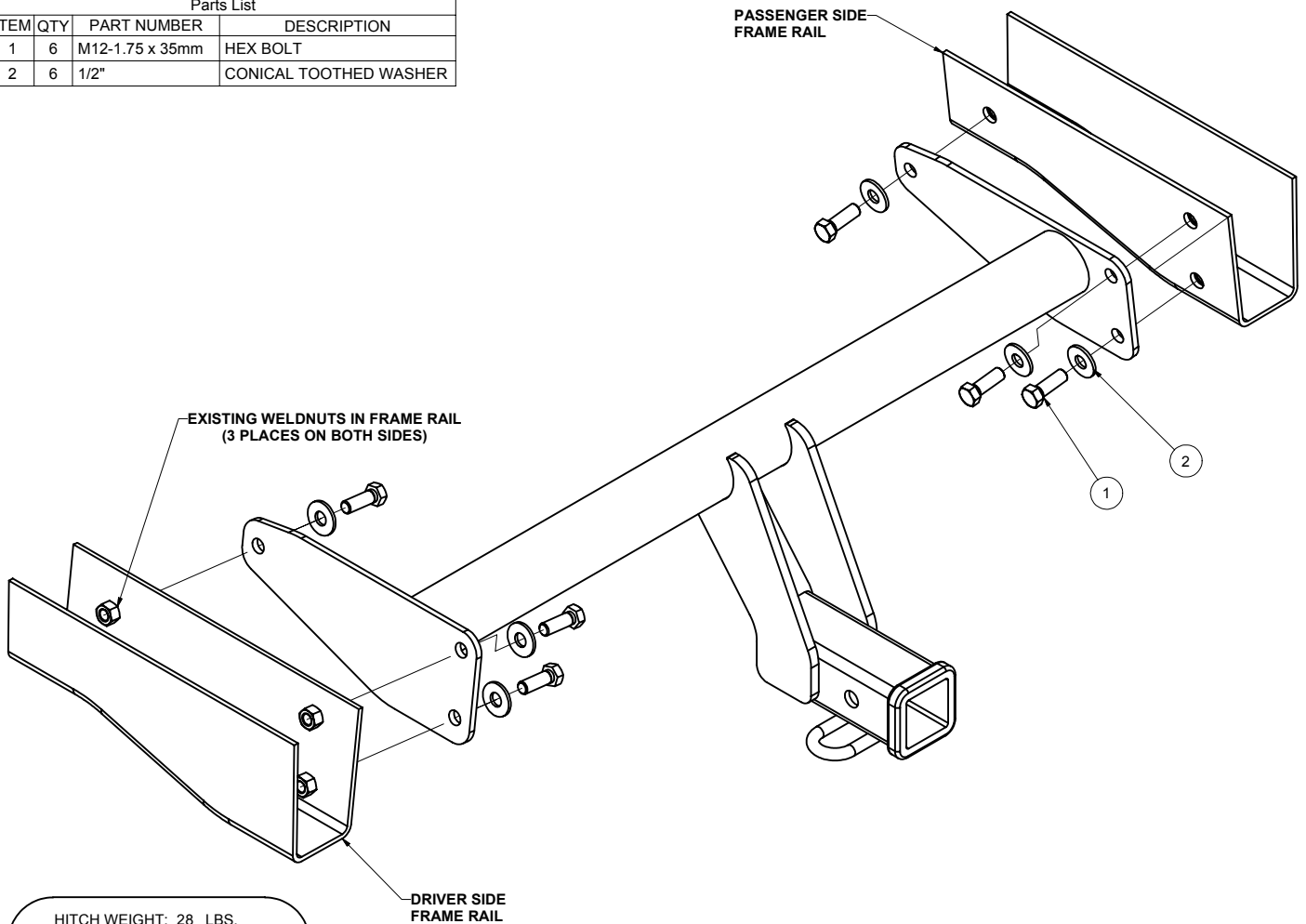

HITCH WEIGHT: 28 LBS.

INSTALL TIME: 20 MINUTES

INSTALL NOTES:

- LOWER EXHAUST
- NO DRILLING REQUIRED

INSTALLATION STEPS

- 1) Lower exhaust by removing rear (4) exhaust hangers. Use a spray lubricant if needed to remove hangers.
- 2) Raise hitch into position between frame rails, aligning holes in hitch with the weldnuts within the frame rails.
- 3) Install supplied hex bolts and conical tooth washers.
- 4) Torque all 12mm fasteners to 60 lb-ft.

PERIODICALLY CHECK THIS RECEIVER HITCH TO ENSURE THAT ALL FASTENERS ARE TIGHT AND THAT ALL STRUCTURAL COMPONENTS ARE SOUND.

Curt Manufacturing Inc., warrants this product to be free of defects in material and/or workmanship at the time of retail purchase by the original purchaser. If the product is found to be defective, Curt Manufacturing Inc., may repair or replace the product, at their option, when the product is returned, prepaid, with proof of purchase. Alteration to, misuse of, or improper installation of this product voids the warranty. Curt Manufacturing Inc.'s liability is limited to repair or replacement of products found to be defective, and specifically excludes liability for incidental or consequential loss or damage.