

GROSS LOAD CAPACITY WHEN USED AS A WEIGHT CARRYING HITCH: 3,500 LBS. TRAILER WEIGHT & 350 LBS. TONGUE WEIGHT.

\*\*\*DO NOT EXCEED VEHICLE MANUFACTURER'S RECOMMENDED TOWING CAPACITY.\*\*\*

WARNING: ALL NON-TRAILER LOADS APPLIED TO THIS PRODUCT MUST BE SUPPORTED BY AUXILIARY STABILIZING STRAPS.

\*\* FAILURE TO PROPERLY SUPPORT NON-TRAILER LOADS WILL VOID PRODUCT WARRANTY\*\*

Parts List			
ITEM	QTY	PART NUMBER	DESCRIPTION
1	4	M12 - 1.25 x 40 HEX	HEX BOLT
2	4	1/2"	CONICAL TOOTHED WASHER
3	1	M10-1.25 x 35	HEX BOLT
4	1	3/8"	CONICAL TOOTHED WASHER

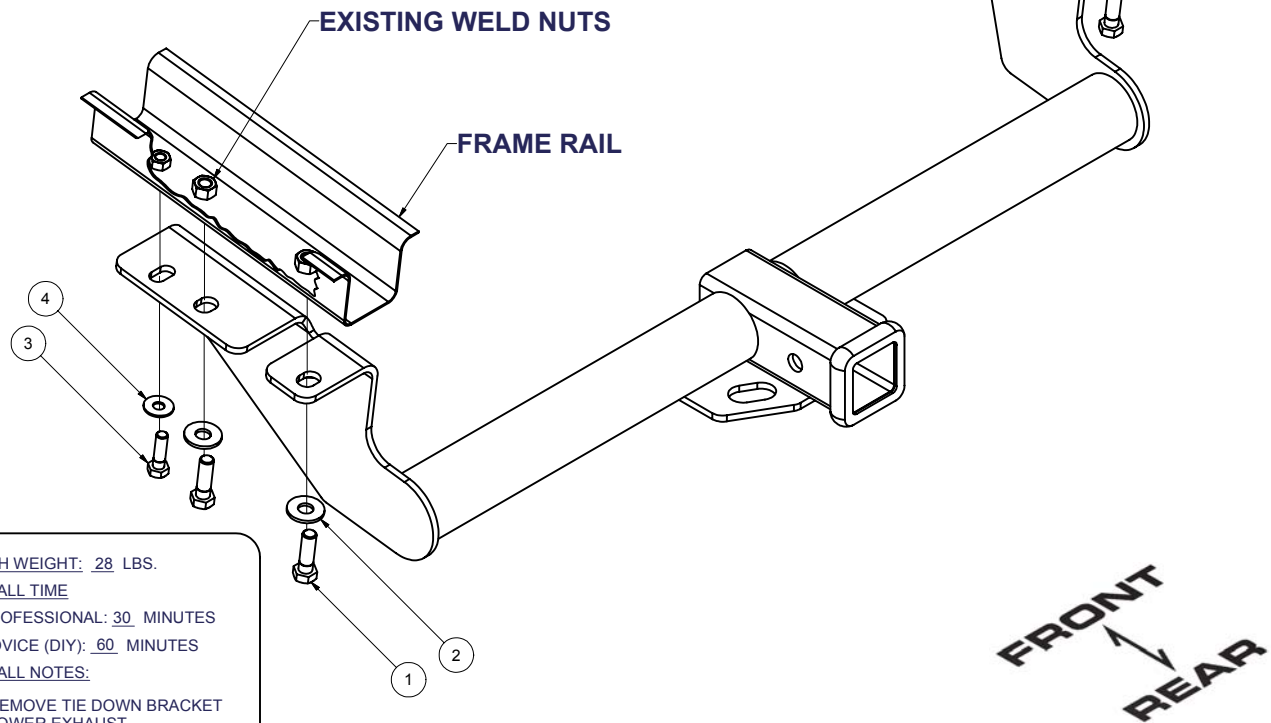
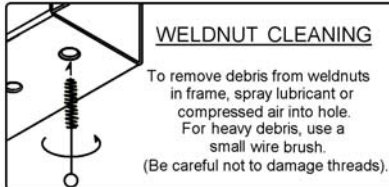

HITCH WEIGHT: 28 LBS.

**INSTALL TIME**

PROFESSIONAL: 30 MINUTES

NOVICE (DIY): 60 MINUTES

**INSTALL NOTES:**

- REMOVE TIE DOWN BRACKET
- LOWER EXHAUST
- NO DRILLING REQUIRED

## INSTALLATION STEPS

1. Remove the tie down bracket under driver's side frame rail. Lower vehicle's exhaust enough to allow hitch assembly to pass over twin exhaust tips and position under frame rails. Support the exhaust to prevent damage.
2. Use conical washers and metric fasteners to attach hitch under frame rails at existing weld nuts as shown in diagram.
3. Torque M12 fasteners to 65 lb.-ft. Torque M10 fasteners to 38 lb.-ft.
4. Raise exhaust back into position lowered in step 1.

**PERIODICALLY CHECK THIS RECEIVER HITCH TO ENSURE THAT ALL FASTENERS ARE TIGHT AND THAT ALL STRUCTURAL COMPONENTS ARE SOUND.**

Curt Manufacturing Inc., warrants this product to be free of defects in material and/or workmanship at the time of retail purchase by the original purchaser. If the product is found to be defective, Curt Manufacturing Inc., may repair or replace the product, at their option, when the product is returned, prepaid, with proof of purchase. Alteration to, misuse of, or improper installation of this product voids the warranty. Curt Manufacturing Inc.'s liability is limited to repair or replacement of products found to be defective, and specifically excludes liability for incidental or consequential loss or damage.