

13506

01-04 FORD ESCAPE & MAZDA TRIBUTE

GROSS LOAD CAPACITY WHEN USED AS A WEIGHT CARRYING HITCH: 3,500 LBS. TRAILER WEIGHT & 350 LBS. TONGUE WEIGHT.
GROSS LOAD CAPACITY WHEN USED AS A WEIGHT DISTRIBUTION HITCH: 5,000 LBS. TRAILER WEIGHT & 500 LBS. TONGUE WEIGHT

DO NOT EXCEED VEHICLE MANUFACTURER'S RECOMMENDED TOWING CAPACITY.

Parts List			
ITEM	QTY	PART NUMBER	DESCRIPTION
1	4	1/2"	CONICAL TOOTHED WASHER
2	4	M12-1.75 x 45mm	HEX BOLT
3	1	1/4"	WASHER
4	1	M6 - 1.00 X 20 HEX BOLT	HEX BOLT
5	1	7_16 FISHWIRE	7/16" FISHWIRE
6	6	CM-SP2	.250 x .88 x 2.25" SQUARE HOLE SPACER
7	6	7/16-14	LARGE HEX FLANGE NUT
8	6	7/16 - 14 x 1 3/4	CARRIAGE BOLT

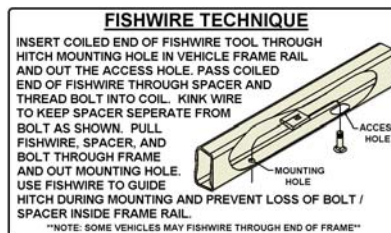
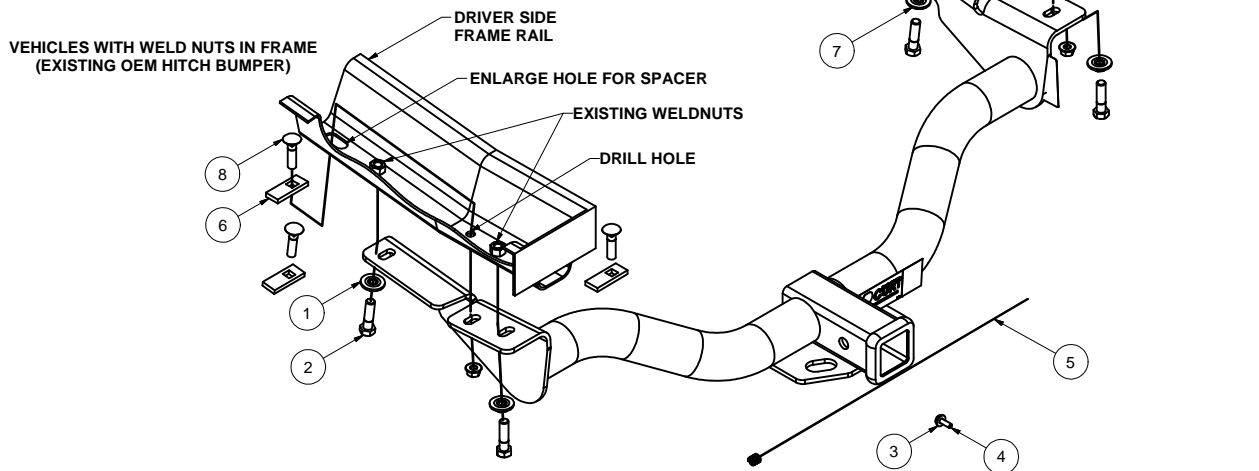

HITCH WEIGHT: 31 LBS.

INSTALL TIME

PROFESSIONAL: 40 MINUTES

NOVICE (DIY): 80 MINUTES

INSTALL NOTES:

- REMOVE HEAT SHIELD
- DRILLING REQUIRED ON SOME VEHICLES

INSTALLATION STEPS

- 1) Remove heat shield on 2002 and earlier models.

For vehicles with frame weld nuts:

Raise hitch into position and secure with hex bolts and washers as shown. Use hitch as a template to locate, and drill center holes. Install carriage bolts and spacers as shown above.

For vehicles without frame weld nuts:

Fishwire carriage bolts and spacers into position as shown. Raise hitch into position and fasten to hitch using supplied hex flange nuts.

- 2) Torque all 12mm fasteners to 59 lb-ft, and all 7/16" fasteners to 50 lb-ft.

- 3) Trim heat shield as required for re-fit, re-install using existing fasteners, except over hitch bracket use new 6mm hex bolt and flat washer supplied with hitch. Torque the 6mm bolt to 10 lb-ft.

PERIODICALLY CHECK THIS RECEIVER HITCH TO ENSURE THAT ALL FASTENERS ARE TIGHT AND THAT ALL STRUCTURAL COMPONENTS ARE SOUND.

Curt Manufacturing Inc., warrants this product to be free of defects in material and/or workmanship at the time of retail purchase by the original purchaser. If the product is found to be defective, Curt Manufacturing Inc., may repair or replace the product, at their option, when the product is returned, prepaid, with proof of purchase. Alteration to, misuse of, or improper installation of this product voids the warranty. Curt Manufacturing Inc.'s liability is limited to repair or replacement of products found to be defective, and specifically excludes liability for incidental or consequential loss or damage.