

13505**01-06 HYUNDAI SANTE FE**

GROSS LOAD CAPACITY WHEN USED AS A WEIGHT CARRYING HITCH: 4,000 LBS. TRAILER WEIGHT & 400 LBS. TONGUE WEIGHT
*****DO NOT EXCEED VEHICLE BUMPER GROSS TOWING CAPACITY, OR USE WITH WEIGHT DISTRIBUTION EQUIPMENT***.**

Parts List			
ITEM	QTY	PART NUMBER	DESCRIPTION
1	6	M10 - 1.25 x 40 HEX	HEX BOLT
2	6	7/16"	CONICAL TOOTHED WASHER

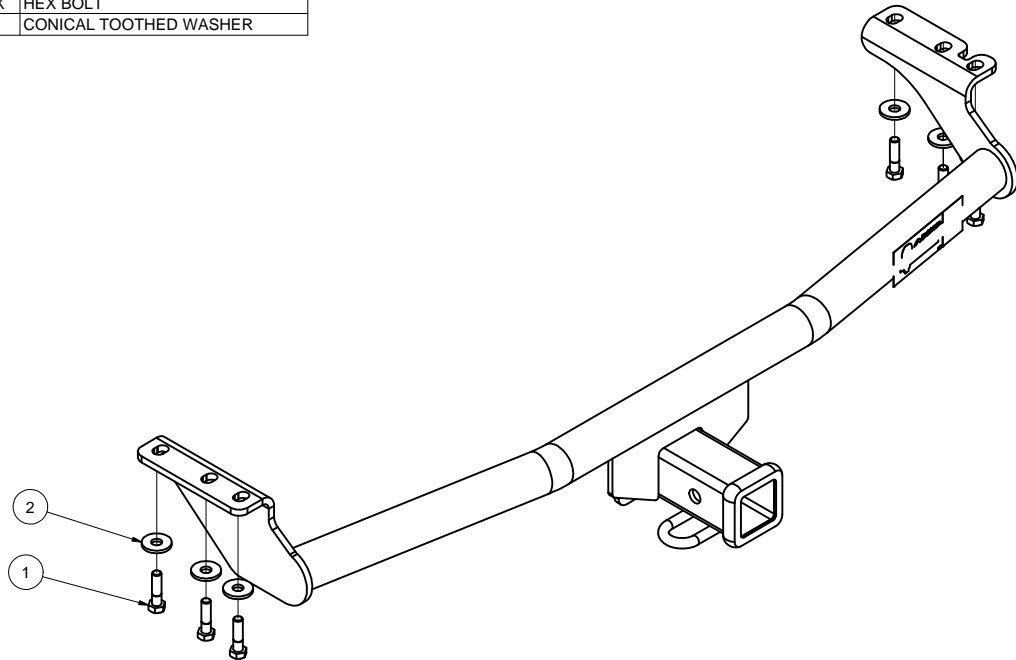

HITCH WEIGHT: 25 LBS.

INSTALL TIME: 45 MINUTES

INSTALL NOTES:

NO DRILLING REQUIRED

INSTALLATION STEPS

- 1) FOR EASE OF INSTALLATION LOWER THE SPARE TIRE OR REMOVE IT.
- 2) THE LOWERING OF THE EXHAUST IS NOT NECESSARY, BUT WILL MAKE THE INSTALLATION EASIER.
- 3) REMOVE THE TOW HOOKS FROM EACH SIDE AND RETURN TO VEHICLE OWNER.
- 4) RAISE THE HITCH INTO POSITION, THE MAIN CROSS TUBE SHOULD BE CONCEALED BEHIND THE REAR FASCIA AND THE PASSENGER SIDE MOUNTING PLATE NOTCH SHOULD WRAP AROUND THE REARMOST EXHAUST HANGER.
- 5) ATTACH THE HITCH WITH THREE M10 FASTENERS ON EACH SIDE.
- 6) TORQUE ALL FASTENERS TO 38 FT/LBS.
- 7) RE-ATTACH THE EXHAUST IF IT WAS LOWERED AND RETURN THE SPARE TIRE TO THE CARRIER.

PERIODICALLY CHECK THIS RECEIVER HITCH TO ENSURE THAT ALL FASTENERS ARE TIGHT AND THAT ALL STRUCTURAL COMPONENTS ARE SOUND.

Curt Manufacturing Inc., warrants this product to be free of defects in material or workmanship at the time of retail purchase by the original purchaser. If the product is found to be defective, Curt Manufacturing Inc., may repair or replace the product, at their option, when the product is returned, prepaid, with proof of purchase. Alteration to, misuse of, or improper installation of this product voids the warrant. Curt Manufacturing Inc.'s liability is limited to repair or replacement of products found to be defective, and specifically excludes liability for incidental or consequential loss or damage.