

13407

2000-06 FORD EXPLORER SPORT TRAC

GROSS LOAD CAPACITY WHEN USED AS A WEIGHT CARRYING HITCH: 5,000 LBS. TRAILER WEIGHT & 500 LBS. TONGUE WEIGHT.  
 GROSS LOAD CAPACITY WHEN USED AS A WEIGHT DISTRIBUTION HITCH: 6,000 LBS. TRAILER WEIGHT & 600 LBS. TONGUE WEIGHT

\*\*\*DO NOT EXCEED VEHICLE MANUFACTURER'S RECOMMENDED TOWING CAPACITY.\*\*\*

Parts List				
ITEM	QTY	PART NUMBER	DESCRIPTION	
1	2	CM-SP1	.250 x 1.50 x 2.00" SQUARE HOLE SPACER	
2	6	7/16	HELICAL LOCK WASHER	
3	2	HFN 1213	HEX FLANGE NUT	
4	2	CM-SP25	.250 x 1.38 x 1.50" ROUND HOLE SPACER	
5	2	9/16-12 x 1 1/2	HEX BOLT	
6	6	7/16-14	HEX NUT	
7	2	9/16 - 12	HEX NUT	
8	6	7/16-14 x 1 1/4	CARRIAGE BOLT	
9	2	1/2-13 x 1 1/2	CARRIAGE BOLT	

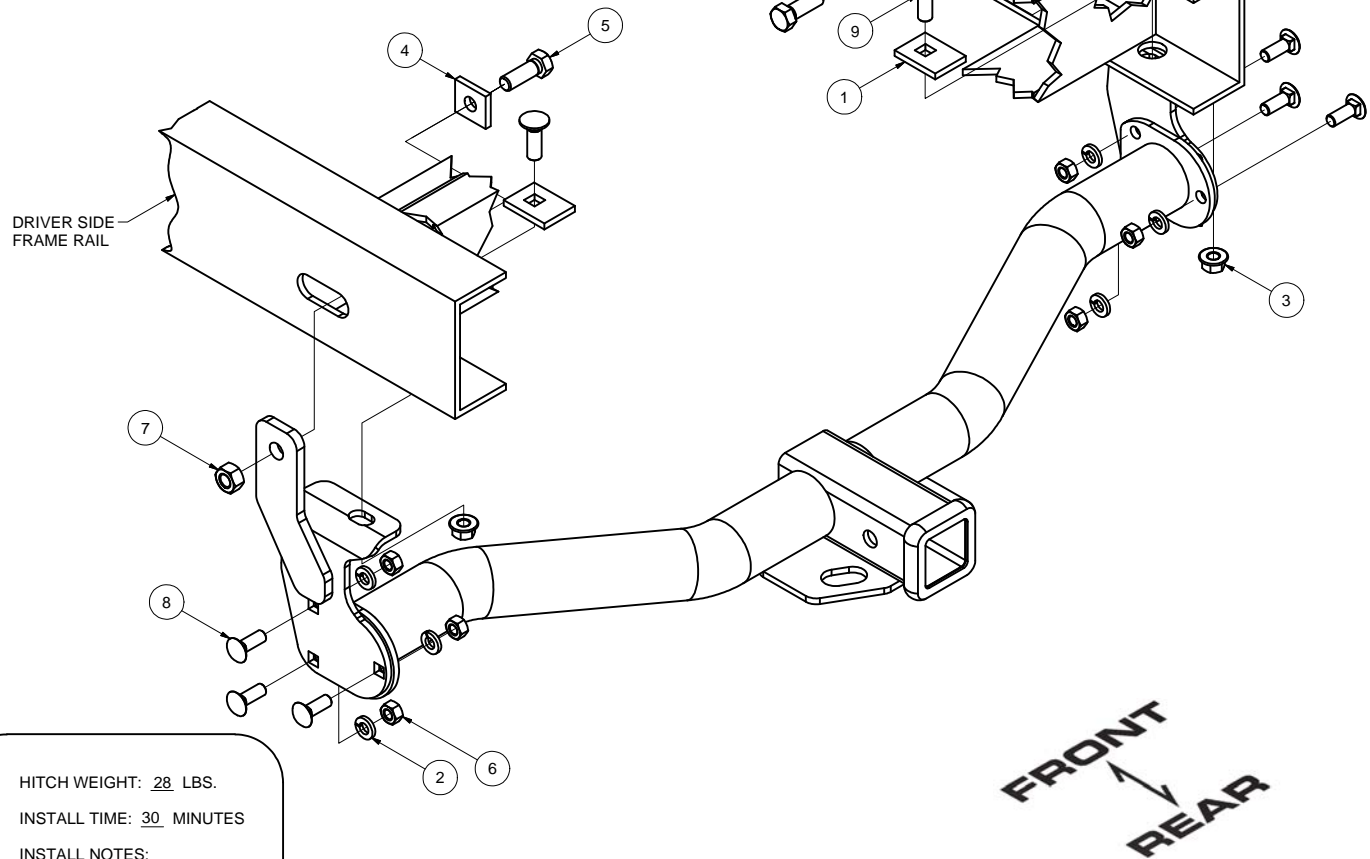

HITCH WEIGHT: 28 LBS.

INSTALL TIME: 30 MINUTES

INSTALL NOTES:

**NO DRILLING REQUIRED**

## INSTALLATION STEPS

- 1) Raise side plates into position under vehicle, placing upright bars against outboard verticle surface of frame. Align hole in the side arm with existing slot in the frame on both sides.

NOTE: If present, relocate wires on driver side of the vehicle to install hitch side plate.

- 2) Loosely install hitch-to-frame fasteners as shown.
- 3) Raise receiver into position and install 7/16" fasteners as shown.
- 4) Torque all 9/16 fasteners to 110 lb.-ft., 1/2" fasteners to 75 lb.-ft., and all 7/16" fasteners to 50 lb.-ft.

PERIODICALLY CHECK THIS RECEIVER HITCH TO ENSURE THAT ALL FASTENERS ARE TIGHT AND THAT ALL STRUCTURAL COMPONENTS ARE SOUND.

Curt Manufacturing Inc., warrants this product to be free of defects in material and/or workmanship at the time of retail purchase by the original purchaser. If the product is found to be defective, Curt Manufacturing Inc., may repair or replace the product, at their option, when the product is returned, prepaid, with proof of purchase. Alteration to, misuse of, or improper installation of this product voids the warranty. Curt Manufacturing Inc.'s liability is limited to repair or replacement of products found to be defective, and specifically excludes liability for incidental or consequential loss or damage.