

13385

HONDA RIDGELINE

GROSS LOAD CAPACITY WHEN USED AS A WEIGHT CARRYING HITCH: 5,000 LBS. TRAILER WEIGHT & 500 LBS. TONGUE WEIGHT.
 GROSS LOAD CAPACITY WHEN USED AS A WEIGHT DISTRIBUTION HITCH: 6,000 LBS. TRAILER WEIGHT & 600 LBS. TONGUE WEIGHT

DO NOT EXCEED VEHICLE MANUFACTURER'S RECOMMENDED TOWING CAPACITY.

Parts List			
ITEM	QTY	PART NUMBER	DESCRIPTION
1	2	M10 - 1.25 x 30	HEX TAP BOLT
2	2	3/8"	CONICAL TOOTHED WASHER
3	6	1/2"	CONICAL TOOTHED WASHER
4	6	M12 - 1.25 x 40 HEX	HEX TAP BOLT
5	1	3/8-16	NYLOCK HEX NUT
6	1	3/8"	WASHER

TOOLS REQUIRED
RATCHET
3" EXTENSION
10" EXTENSION
17mm SOCKET
20mm SOCKET
5/8" WRENCH
PRY BAR
TORQUE WRENCH

DIAGRAM A

RUBBER ISOLATOR REMOVAL DIAGRAM

This technique can be used if an Exhaust Hanger Removal Pliers is not available.

Using a 5/8" open end wrench, slide the wrench up to the rubber isolator, cradling the hanger rod as shown. Next place the flat edge of a pry bar between the wrench and the hanger stop or hanger rod. Then simply rotate the pry bar toward the wrench to remove the rubber isolator.

Note: Using a spray lubricant or soapy water on the hanger rod and the rubber isolator helps removal.

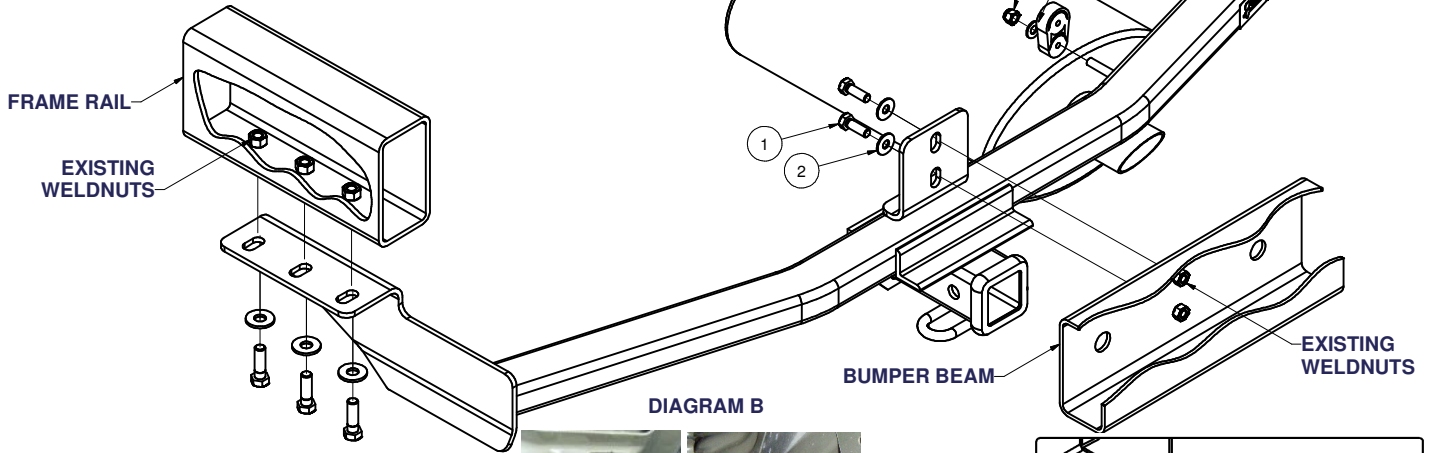
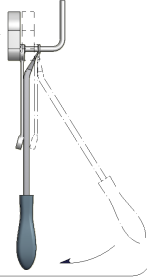

HITCH WEIGHT: 38 LBS.
 INSTALL TIME: 30 MINUTES

INSTALL NOTES:

- NO DRILLING REQUIRED
- LOWER EXHAUST
- HANGER RELOCATION REQUIRED

EXHAUST ISOLATION MOUNT IN FACTORY POSITION



EXHAUST ISOLATION MOUNT IN POSITION WITH HITCH INSTALLED

WELDNUIT CLEANING

To remove debris from weldnuts in frame, spray lubricant or compressed air into hole. For heavy debris, use a small wire brush. (Be careful not to damage threads).

INSTALLATION STEPS

- 1) Lower exhaust hangers at front and rear of muffler for ease of installation. (See Diagram A)
- 2) Raise hitch into position, between exhaust pipe and vehicle frame.
- 3) Secure hitch to frame rails using M12 bolts and conical washers as shown, finger tighten.
- 4) Secure hitch to bumper beam using M10 bolts and conical washers as shown, finger tighten.
- 5) Re-install exhaust hangers removed in step 1. Install rear exhaust hanger onto hitch exhaust stud as shown. (See Diagram B) Retain hanger with 3/8-16 nylock hex nut and washer.
- 6) Torque all M12 fasteners first to 68 lb-ft and all M10 fasteners second to 42 lb-ft. Tighten 3/8" nylock nut until washer contacts isolator. Confirm engagement of nylock with stud thread.

PERIODICALLY CHECK THIS RECEIVER HITCH TO ENSURE THAT ALL FASTENERS ARE TIGHT AND THAT ALL STRUCTURAL COMPONENTS ARE SOUND.

Curt Manufacturing Inc., warrants this product to be free of defects in material and/or workmanship at the time of retail purchase by the original purchaser. If the product is found to be defective, Curt Manufacturing Inc., may repair or replace the product, at their option, when the product is returned, prepaid, with proof of purchase. Alteration to, misuse of, or improper installation of this product voids the warranty. Curt Manufacturing Inc.'s liability is limited to repair or replacement of products found to be defective, and specifically excludes liability for incidental or consequential loss or damage.