

13364

DODGE GRAND CARAVAN S, SXT / CHRYSLER TOWN AND COUNTRY TOURING /  
VOLKSWAGEN ROUTAN S, SE, SEL / RAM CARGO VAN

GROSS LOAD CAPACITY WHEN USED AS A WEIGHT CARRYING HITCH: 4,000 LBS. TRAILER WEIGHT & 400 LBS. TONGUE WEIGHT.  
GROSS LOAD CAPACITY WHEN USED AS A WEIGHT DISTRIBUTION HITCH: 5,000 LBS. TRAILER WEIGHT & 500 LBS. TONGUE WEIGHT.

**\*\*\*DO NOT EXCEED VEHICLE MANUFACTURER'S RECOMMENDED TOWING CAPACITY.\*\*\***

WARNING: ALL NON-TRAILER LOADS APPLIED TO THIS PRODUCT MUST BE SUPPORTED BY AUXILIARY STABILIZING STRAPS.

**\*\* FAILURE TO PROPERLY SUPPORT NON-TRAILER LOADS WILL VOID PRODUCT WARRANTY\*\***

**TOOLS REQUIRED**

3/8" DRIVE RATCHET
18mm - 3/8" DRIVE SOCKET
15mm - 3/8" DRIVE SOCKET
13mm - 3/8" DRIVE SOCKET
TORQUE WRENCH
SCREW DRIVER / PUNCH

**\*\*CAUTION\*\***

BE SURE WHEN TIGHTENING  
HITCH TO VEHICLE, HITCH  
DOES NOT PINCH OR CRUSH  
AC LINES (IF PRESENT)

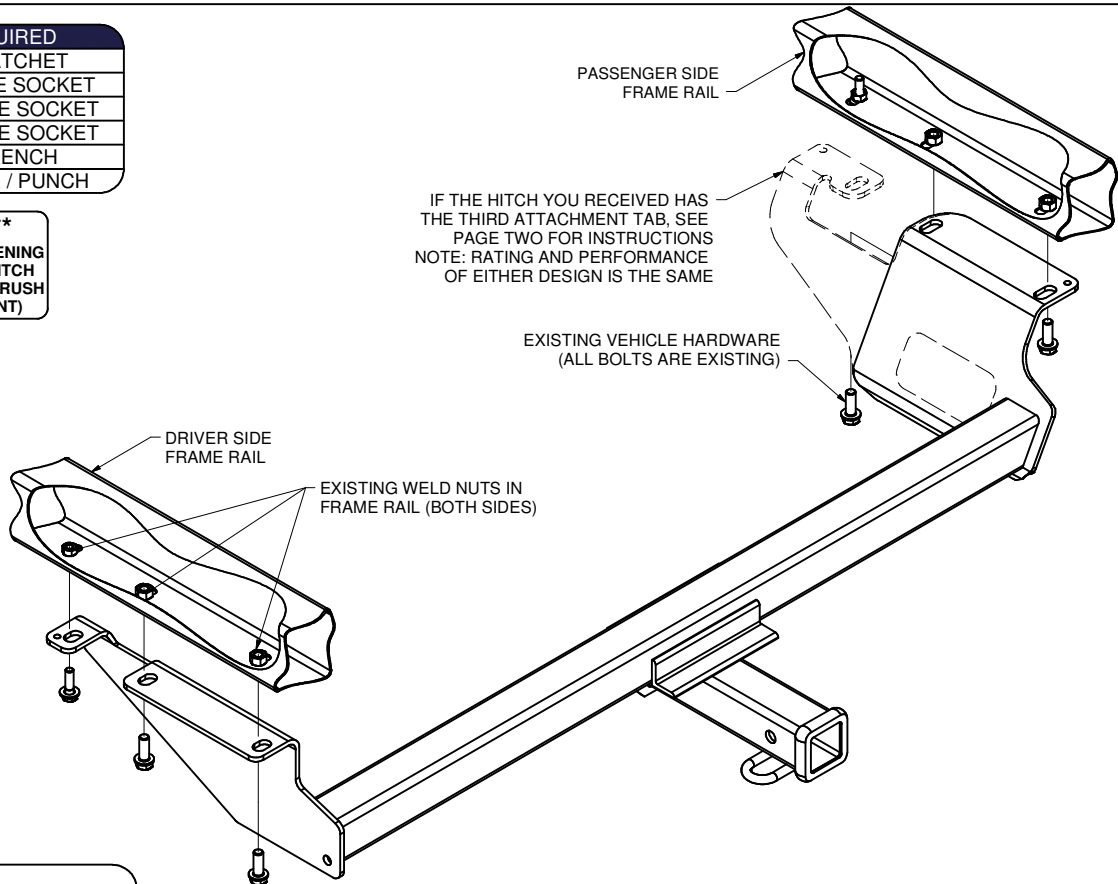

HITCH WEIGHT: 49 LBS.  
INSTALL TIME: 25 MINUTES  
INSTALL NOTES:  
- NO DRILLING REQUIRED  
- USE EXISTING FASTENERS  
- LOWER EXHAUST

**\*\*\* USE EXISTING VEHICLE HARDWARE \*\*\***

**INSTALLATION STEPS**

- 1) Locate and remove the (2) bolts using a 15mm socket and (3) bolts using a 18mm socket as shown above. Leave (1) 12mm bolt on passenger side of vehicle frame toward the front of vehicle that holds the bumper bracket to vehicle frame. Remove the bolt(s) holding the exhaust and muffler hanger(s). This will allow exhaust to drop down out of the way for hitch installation.
  - 2) Raise hitch into position against the bottom of vehicle frame and align holes in hitch frame brackets with the holes in vehicle frame. Be sure air conditioning (AC) lines are not pinched between hitch and frame rail (if AC lines are present).
  - 3) Mount hitch using existing 10mm and 12mm bolts, may need a punch or screw driver to align holes.
  - 4) Torque all 10mm fasteners to 53 lb-ft, and all 12mm fasteners to 73 lb-ft.
  - 5) Raise the muffler and re-install any other exhaust bolts removed earlier in Step 1.
- NOTE: Rotating exhaust hanger bracket before tightening will add clearance between side bracket and exhaust.

**PERIODICALLY CHECK THIS RECEIVER HITCH TO ENSURE THAT ALL FASTENERS ARE TIGHT AND THAT ALL STRUCTURAL COMPONENTS ARE SOUND.**

Curt Manufacturing Inc., warrants this product to be free of defects in material and/or workmanship at the time of retail purchase by the original purchaser. If the product is found to be defective, Curt Manufacturing Inc., may repair or replace the product, at their option, when the product is returned, prepaid, with proof of purchase. Alteration to, misuse of, or improper installation of this product voids the warranty. Curt Manufacturing Inc.'s liability is limited to repair or replacement of products found to be defective, and specifically excludes liability for incidental or consequential loss or damage.

13364

**DODGE GRAND CARAVAN S, SXT / CHRYSLER TOWN AND COUNTRY TOURING /  
VOLKSWAGEN ROUTAN S, SE, SEL / RAM CARGO VAN**

**GROSS LOAD CAPACITY WHEN USED AS A WEIGHT CARRYING HITCH: 4,000 LBS. TRAILER WEIGHT & 400 LBS. TONGUE WEIGHT.  
GROSS LOAD CAPACITY WHEN USED AS A WEIGHT DISTRIBUTION HITCH: 5,000 LBS. TRAILER WEIGHT & 500 LBS. TONGUE WEIGHT.**

**\*\*\*DO NOT EXCEED VEHICLE MANUFACTURER'S RECOMMENDED TOWING CAPACITY.\*\*\***

**WARNING: ALL NON-TRAILER LOADS APPLIED TO THIS PRODUCT MUST BE SUPPORTED BY AUXILIARY STABILIZING STRAPS.**

**\*\* FAILURE TO PROPERLY SUPPORT NON-TRAILER LOADS WILL VOID PRODUCT WARRANTY\*\***

Parts List			
ITEM	QTY	PART NUMBER	DESCRIPTION
1	1	5/16-18	HEX FLANGE NUT
2	1	5_16-18 X 1.00 HHCS	5_16-18 X 1.00 HHCS

TOOLS REQUIRED
3/8" DRIVE RATCHET
18mm - 3/8 DRIVE SOCKET
15mm - 3/8" DRIVE SOCKET
13mm - 3/8" DRIVE SOCKET
TORQUE WRENCH
SCREW DRIVER / PUNCH

**\*\*CAUTION\*\***

**BE SURE WHEN TIGHTENING  
HITCH TO VEHICLE, HITCH  
DOES NOT PINCH OR CRUSH  
AC LINES (IF PRESENT)**

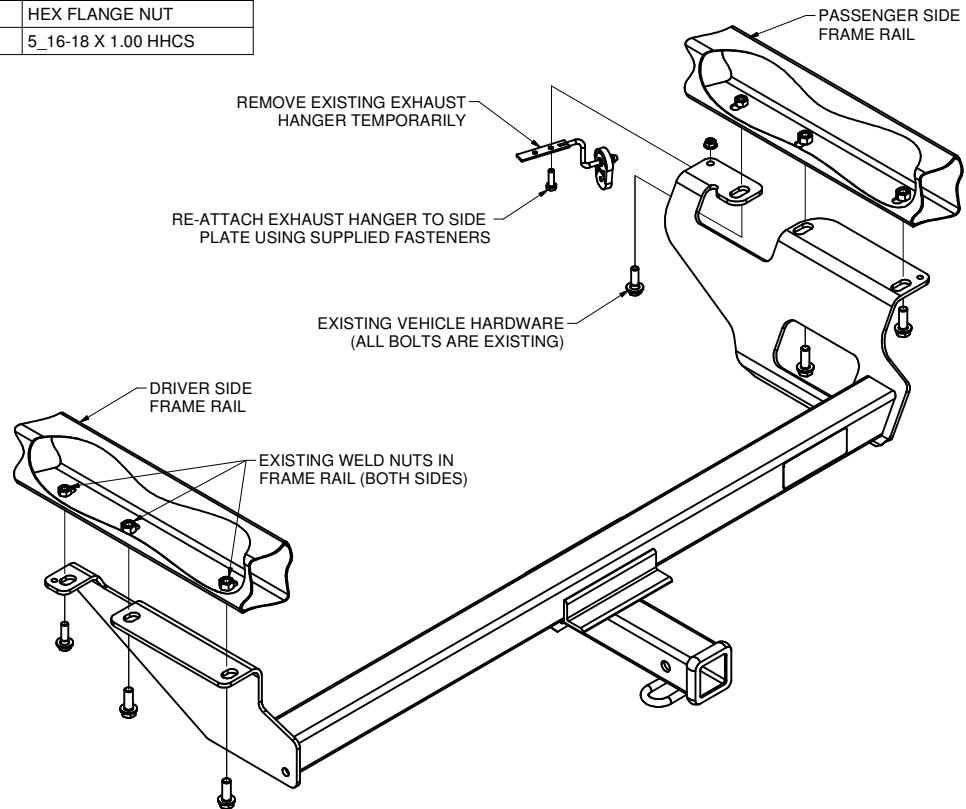

HITCH WEIGHT: 49 LBS.  
INSTALL TIME: 25 MINUTES  
INSTALL NOTES:  
- NO DRILLING REQUIRED  
- USE EXISTING FASTENERS  
- LOWER EXHAUST

**\*\*\* USE EXISTING VEHICLE HARDWARE \*\*\***

**\*\*\* SUPPORT BUMPER BEAM IN PLACE WHEN BOLTS ARE REMOVED,  
RE-ALIGN HOLES IN FRAME WITH BEAM WELDNUTS \*\*\***

## INSTALLATION STEPS

- 1) Locate and remove the (1) bolts using a 15mm socket and (2) bolts using a 18mm socket on both the driver and passenger side vehicle frame toward the rear of vehicle that holds the bumper bracket to vehicle frame. Remove the bolt(s) holding the exhaust and muffler hanger(s). This will allow exhaust to drop down out of the way for hitch installation.
- 2) Raise hitch into position against the bottom of vehicle frame and align holes in hitch frame brackets with the holes in vehicle frame. Be sure air conditioning (AC) lines are not pinched between hitch and frame rail (if AC lines are present).
- 3) Mount hitch using existing 10mm and 12mm bolts, may need a punch or screw driver to align holes.
- 4) Torque all 10mm fasteners to 53 lb-ft, and all 12mm fasteners to 73 lb-ft.
- 5) Raise the muffler and install the supplied bolt and nut to hanger. Re-install any other exhaust bolts removed earlier in Step 1.

**NOTE:** Rotating exhaust hanger bracket before tightening will add clearance between side bracket and exhaust.

**PERIODICALLY CHECK THIS RECEIVER HITCH TO ENSURE THAT ALL FASTENERS  
ARE TIGHT AND THAT ALL STRUCTURAL COMPONENTS ARE SOUND.**

Curt Manufacturing Inc., warrants this product to be free of defects in material and/or workmanship at the time of retail purchase by the original purchaser. If the product is found to be defective, Curt Manufacturing Inc., may repair or replace the product, at their option, when the product is returned, prepaid, with proof of purchase. Alteration to, misuse of, or improper installation of this product voids the warranty. Curt Manufacturing Inc.'s liability is limited to repair or replacement of products found to be defective, and specifically excludes liability for incidental or consequential loss or damage.