



Safety glasses should be worn at all times while installing this product.

YEARS: 2010-PRESENT

MAKE: LEXUS

MODEL: RX 350 (INCLUDING F SPORT) & RX 450H

STYLE: CROSSOVER SUV

WARNING: NEVER EXCEED YOUR VEHICLE MANUFACTURER'S RECOMMENDED TOWING CAPACITY

WEIGHT CARRYING:
 TRAILER WEIGHT: 4,000 LBS.
 TONGUE WEIGHT: 600 LBS.

WEIGHT DISTRIBUTION:
 TRAILER WEIGHT: 5,000 LBS.
 TONGUE WEIGHT: 600 LBS.

PRO INSTALL TIME: 35 MIN.
NOVICE INSTALL TIME: 70 MIN.

IF YOU ARE HESITANT TO UNDERTAKE THIS TASK ON YOUR OWN, CONTACT AN AUTHORIZED CURT INSTALLER FOR ADDITIONAL ASSISTANCE.

INSTALLATION REQUIRES:

		10mm 17mm 19mm
ROTARY TOOL	RATCHET	SOCKET
9" SOCKET EXTENSION	TORQUE WRENCH	SCREW DRIVER
MASKING TAPE	TAPE MEASURE	SAFETY GLASSES
AVIATION SHEARS		

INSTALLATION TIPS:

- BEFORE YOU BEGIN INSTALLATION, READ ALL INSTRUCTIONS THOROUGHLY.
- TO EASE INSTALLATION, 2 PEOPLE MAY BE REQUIRED.
- USING PROPER TOOLS WILL GREATLY IMPROVE THE QUALITY OF THE INSTALL AND REDUCE THE TIME REQUIRED.

LEVEL OF DIFFICULTY: MODERATE

EASY	MODERATE	CHALLENGING
	REMOVE UNDERBODY PANEL	
	REMOVE (2) TOW LOOPS	
	UNDERBODY PANEL TRIMMING REQUIRED	
	MAY REQUIRE WELDNUT CLEANING	
	NO DRILLING REQUIRED	

VEHICLE PHOTO:



REPRESENTATIVE PHOTO

HITCH ILLUSTRATION:

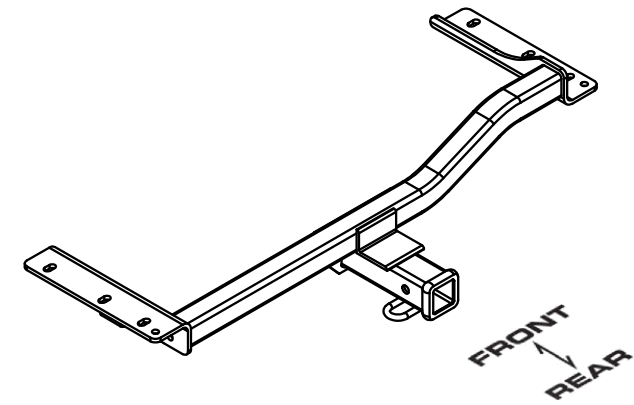

MAKE SURE YOUR HITCH MATCHES

PERIODICALLY CHECK THIS RECEIVER HITCH TO ENSURE ALL FASTENERS ARE TIGHT AND ALL STRUCTURAL COMPONENTS ARE SOUND

CURT Manufacturing LLC. warrants this product to be free of defects in material and/or workmanship at the time of retail purchase by the original purchaser. If the product is found to be defective, Curt Manufacturing LLC. may repair or replace the product at their option, when the product is returned, prepaid, with proof of purchase. Alteration to, misuse of, or improper installation of this product voids the warranty. Curt Manufacturing LLC.'s liability is limited to repair or replacement of products found to be defective, and specifically excludes liability for incidental or consequential loss or damage.

INSTALLATION WALKTHROUGH:

Parts List			
ITEM	QTY	PART NUMBER	DESCRIPTION
1	6	M12 - 1.25 x 40 HEX	HEX BOLT
2	6	7/16"	CONICAL TOOTHED WASHER

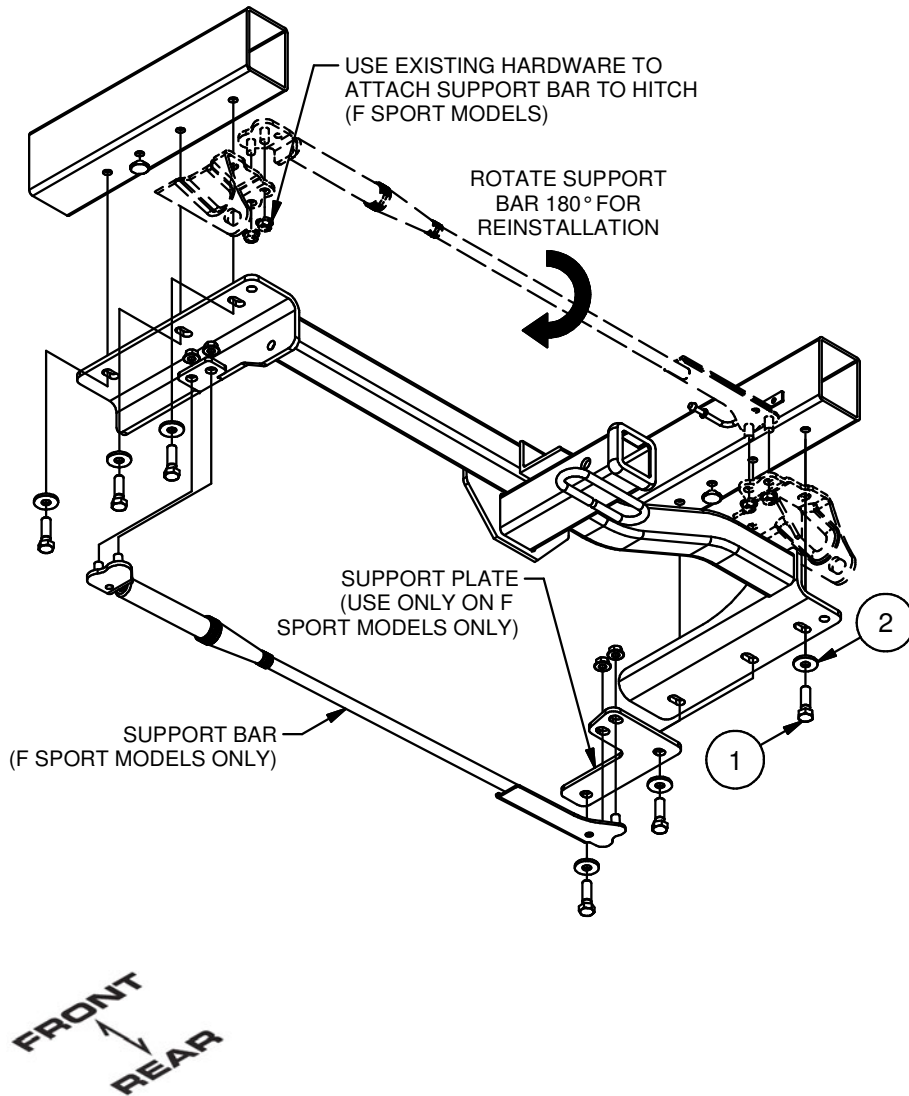

1. Remove (13) fasteners that secure the lower fascia, using a flat head screw driver and 10mm socket. Fastener (1) removal.

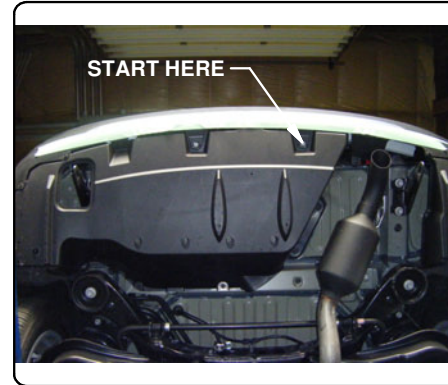

2. Fastener (2 and 3) removal.



INSTALLATION WALKTHROUGH:

3. Fastener (4 and 5) removal.



4. Fastener (6) removal. (First photo shows removal technique using flat blade screwdriver.)



5. Fastener (7 and 8) removal.



6. Fastener (9) is hidden behind wheel well trim. Pull back wheel well trim and remove plunger style fastener.

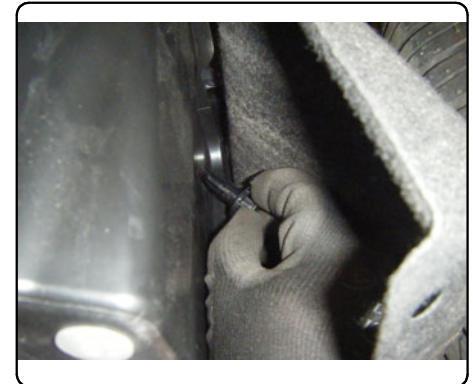

INSTALLATION WALKTHROUGH:

7. Fasteners (10 and 11) removal.



8. Fasteners (12 and 13) removal. Unscrew fasteners, you may need to pull down on plastic to pop fascia free. Remove fascia and place in a safe area. Fascia will be reinstalled in step (17).



9. Using a 17mm socket remove tow loops from the driver and passenger side frame rails.

(F Sport models only) Remove support bar which is attached to tow loops by removing four nuts. The existing nuts will be used to attach the support bar to the hitch.

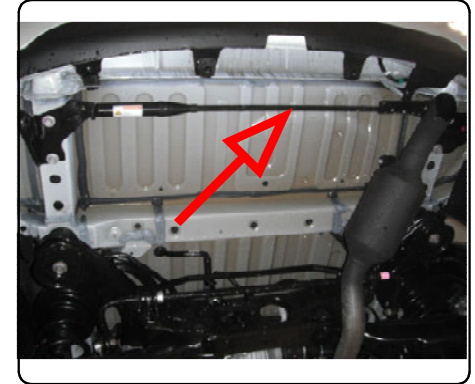

10. Remove hole plugs from the driver and passenger side frame rails. The second photo shows all the hardware that was removed. (F Sport will have four additional nuts.)

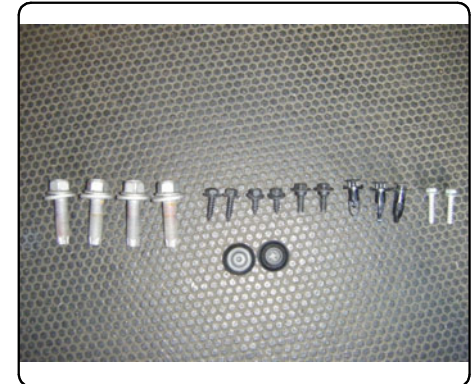
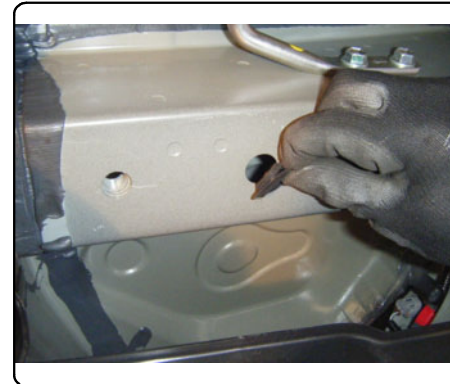

INSTALLATION WALKTHROUGH:

11. Clean weld nuts if necessary. Raise hitch into position starting with the passenger side plate. Pull down on the exhaust and slide the passenger side plate into position. Align holes in the frame rails with the holes in the hitch.

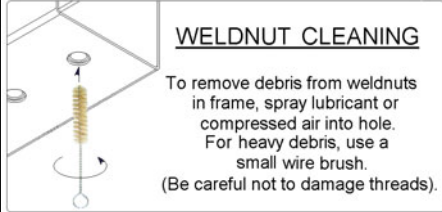

12. Secure hitch and tow loops with supplied 12mm bolts and 7/16" conical toothed washers into weldnuts.

NOTE: (F Sport models only) Place support plate under passenger side plate, as shown on page 2. Hitch will be clamped between frame and support plate.

NOTE: Tow loops cannot be reattached on F Sport models. Tow loop reattachment is optional on other models.

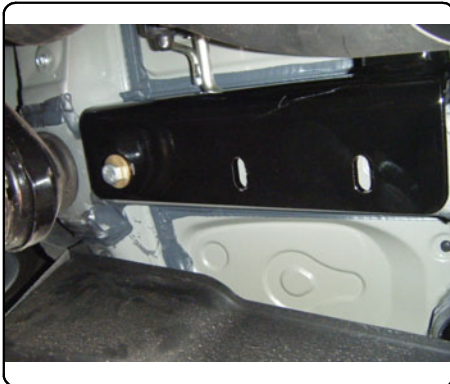

13. Torque all 12mm fasteners to 86 ft-lbs.

(F Sport models only) Attach the support bar to the hitch and support plate using the existing nuts.

NOTE: Support bar will be rotated upside down from how it was originally attached to the tow loops.

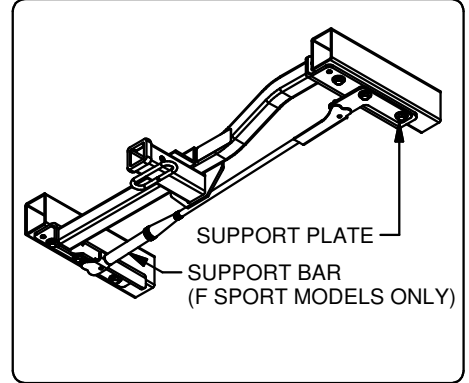

14. Installed hitch shown in proper position.

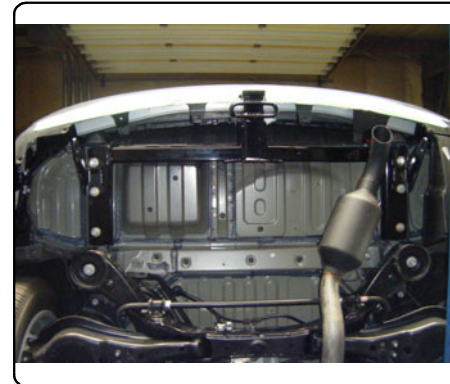

INSTALLATION WALKTHROUGH:

15. Fascia trim details.

NOTE: Consult vehicle owner prior to trimming.

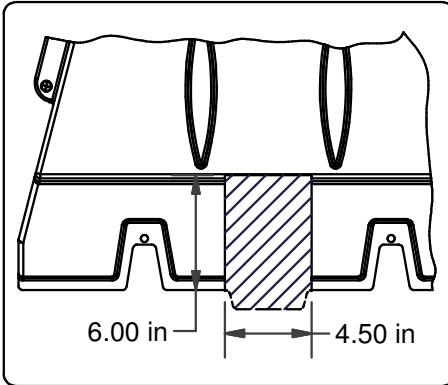

16. Using masking tape, layout the area to be trimmed, as shown. Use a rotary tool (or aviation shears) to trim the fascia.



17. Raise fascia back into position, check for proper fit and clearance. If fascia doesn't fit properly trim and try again. Reattach fascia using existing hardware removed earlier. Return all unused hardware to vehicle owner.



18. Completed hitch installation shown.



13143

LEXUS RX 350 (INCLUDING F SPORT) & RX 450H

3/20/2013

GROSS LOAD CAPACITY WHEN USED AS A WEIGHT CARRYING HITCH: 4,000 LBS. TRAILER WEIGHT & 600 LBS. TONGUE WEIGHT.
GROSS LOAD CAPACITY WHEN USED AS A WEIGHT DISTRIBUTION HITCH: 5,000 LBS. TRAILER WEIGHT & 600 LBS. TONGUE WEIGHT

*****DO NOT EXCEED VEHICLE MANUFACTURER'S RECOMMENDED TOWING CAPACITY.*****

Parts List			
ITEM	QTY	PART NUMBER	DESCRIPTION
1	6	M12 - 1.25 x 40 HEX	HEX BOLT
2	6	7/16"	CONICAL TOOTHED WASHER

TOOLS REQUIRED
RATCHET
TORQUE WRENCH
9" SOCKET EXTENSION
10mm SOCKET
17mm SOCKET
19mm SOCKET
SCREW DRIVER
AVIATION SHEARS

WELDNUT CLEANING

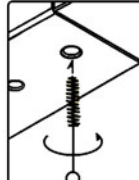

To remove debris from weldnuts in frame, spray lubricant or compressed air into hole. For heavy debris, use a small wire brush. (Be careful not to damage threads).

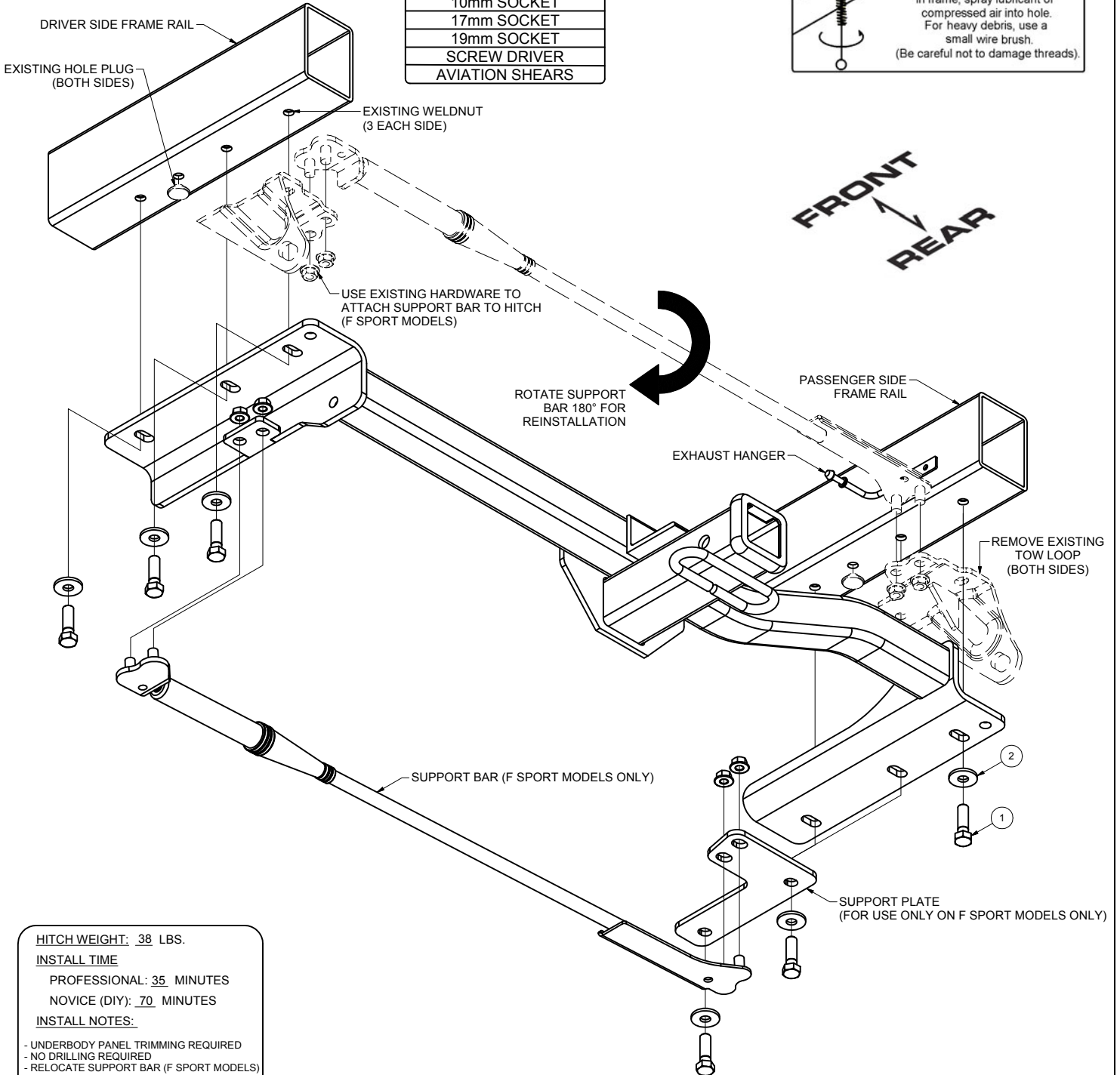

HITCH WEIGHT: 38 LBS.

INSTALL TIME

PROFESSIONAL: 35 MINUTES

NOVICE (DIY): 70 MINUTES

INSTALL NOTES:

- UNDERBODY PANEL TRIMMING REQUIRED
- NO DRILLING REQUIRED
- RELOCATE SUPPORT BAR (F SPORT MODELS)

PERIODICALLY CHECK THIS RECEIVER HITCH TO ENSURE THAT ALL FASTENERS ARE TIGHT AND THAT ALL STRUCTURAL COMPONENTS ARE SOUND.

13143

LEXUS RX 350 (INCLUDING F SPORT) & RX 450H

GROSS LOAD CAPACITY WHEN USED AS A WEIGHT CARRYING HITCH: 4,000 LBS. TRAILER WEIGHT & 600 LBS. TONGUE WEIGHT.
GROSS LOAD CAPACITY WHEN USED AS A WEIGHT DISTRIBUTION HITCH: 5,000 LBS. TRAILER WEIGHT & 600 LBS. TONGUE WEIGHT

*****DO NOT EXCEED VEHICLE MANUFACTURER'S RECOMMENDED TOWING CAPACITY.*****

**RUBBER ISOLATOR
REMOVAL DIAGRAM**

This technique can be used if an Exhaust Hanger Removal Pliers is not available.

Using a 5/8" open end wrench, slide the wrench up to the rubber isolator, cradling the hanger rod as shown. Next place the flat edge of a pry bar between the wrench and the hanger stop or hanger rod. Then simply rotate the pry bar toward the wrench to remove the rubber isolator.

Note: Using a spray lubricant or soapy water on the hanger rod and the rubber isolator helps removal.

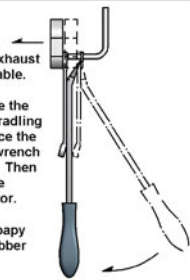

TRIM FASCIA AS NEEDED
FOR HITCH / SUPPORT
BAR (ON F SPORT MODELS)

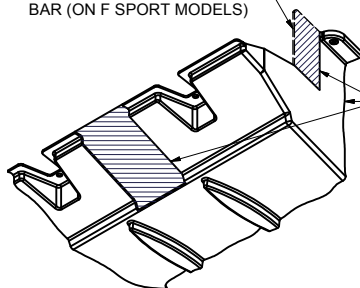

TRIM UNDERBODY PANEL
AS NEEDED FOR
HITCH & SUPPORT BAR

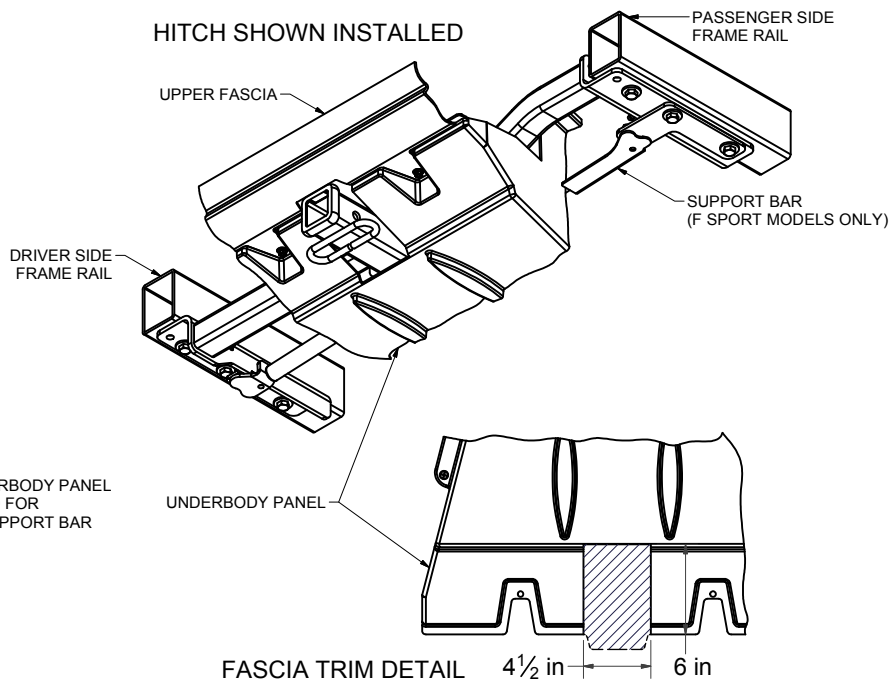
HITCH SHOWN INSTALLED

FASCIA TRIM DETAIL 4½ in 6 in

INSTALLATION STEPS

NOTE: Tow loops cannot be reattached on F Sport models. Tow loop reattachment is optional on other models.

1. Temporarily remove lower fascia by removing 13 fasteners.
2. Temporarily lower exhaust, if needed for ease of installation. Support exhaust as needed to prevent damage.
3. Remove existing hole plugs from frame rails and return to owner.
4. (F Sport models only) Remove support bar which is attached to tow loops by removing four nuts. The existing nuts will be used to attach the support bar to the hitch in STEP 7.
5. Remove existing tow loop fasteners and tow loops. Return fasteners to owner (they will not be reinstalled).
6. Raise hitch (with tow loops if they are being reinstalled) into position by aligning with existing weldnuts in frame.
NOTE: Hitch will be clamped between tow loops and frame rails if tow loops are being reinstalled.
NOTE: (F Sport models only) Place support plate under passenger side plate, as shown on page 1. Hitch will be clamped between frame and support plate.
7. Secure hitch with 12mm bolts and 7/16" conical toothed washers into existing weldnuts.
8. (F Sport models only) Attach the support bar to the hitch and support plate using the existing nuts removed in STEP 4.
NOTE: Support bar will be rotated upside down from how it was originally attached to the tow loops.
9. Torque all 12mm fasteners to 86 ft-lbs.
10. Reinstall exhaust, if it was lowered in STEP 2.
11. Trim lower fascia as needed and reattach. (See FASCIA TRIM DETAIL above)

PERIODICALLY CHECK THIS RECEIVER HITCH TO ENSURE THAT ALL FASTENERS ARE TIGHT AND THAT ALL STRUCTURAL COMPONENTS ARE SOUND.