



# 13120 INSTALLATION INSTRUCTIONS



Safety glasses should be worn at all times while installing this product.

YEARS: 2011-PRESENT

MAKE: KIA/HYUNDAI

MODEL: SPORTAGE/TUCSON

STYLE: CROSSOVER

**WARNING: NEVER EXCEED YOUR VEHICLE MANUFACTURER'S RECOMMENDED TOWING CAPACITY**

**WEIGHT CARRYING:**

TRAILER WEIGHT: 3500 LBS.  
 TONGUE WEIGHT: 525 LBS.







**WEIGHT DISTRIBUTION:**

TRAILER WEIGHT: 5250 LBS.  
 TONGUE WEIGHT: 525 LBS.

**INSTALLATION TIME: 15 MIN.**

THE INSTALL TIME LISTED IS FOR PROFESSIONAL INSTALLERS. IF YOU ARE HESITANT TO UNDERTAKE THIS TASK ON YOUR OWN, CONTACT AN AUTHORIZED CURT INSTALLER FOR ADDITIONAL ASSISTANCE.



**INSTALLATION REQUIRES:**

 <b>RATCHET</b>	 <b>TORQUE WRENCH</b>	 <b>9" SOCKET EXTENSION</b>
 <b>17mm SOCKET</b>	 <b>PRY BAR</b>	 <b>SAFETY GLASSES</b>

**INSTALLATION TIPS:**

- BEFORE YOU BEGIN INSTALLATION, READ ALL INSTRUCTIONS THOROUGHLY.
- TO EASE INSTALLATION, 2 PEOPLE MAY BE REQUIRED.
- USING PROPER TOOLS WILL GREATLY IMPROVE THE QUALITY OF THE INSTALL AND REDUCE THE TIME REQUIRED.

**LEVEL OF DIFFICULTY: EASY**

EASY	MODERATE	CHALLENGING
	-NO DRILLING REQUIRED	
	-LOWER EXHAUST TO EASE INSTALLATION	

**VEHICLE PHOTO:**



REPRESENTATIVE PHOTO

**HITCH ILLUSTRATION:**

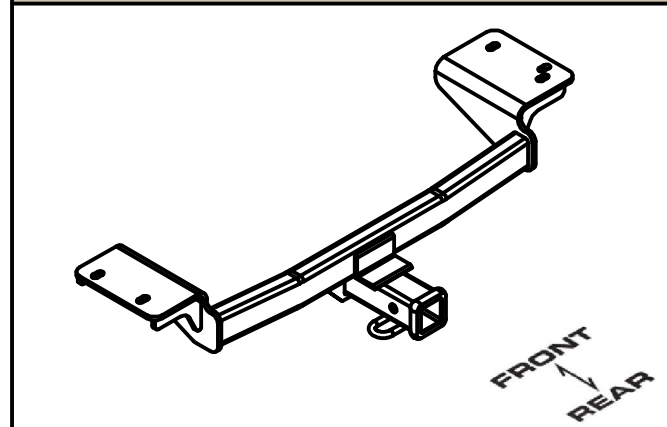

MAKE SURE YOUR HITCH MATCHES

**PERIODICALLY CHECK THIS RECEIVER HITCH TO ENSURE ALL FASTENERS ARE TIGHT AND ALL STRUCTURAL COMPONENTS ARE SOUND**

CURT Manufacturing LLC. warrants this product to be free of defects in material and/or workmanship at the time of retail purchase by the original purchaser. If the product is found to be defective, Curt Manufacturing LLC. may repair or replace the product at their option, when the product is returned, prepaid, with proof of purchase. Alteration to, misuse of, or improper installation of this product voids the warranty. Curt Manufacturing LLC.'s liability is limited to repair or replacement of products found to be defective, and specifically excludes liability for incidental or consequential loss or damage.

# INSTALLATION WALKTHROUGH:

Parts List			
ITEM	QTY	PART NUMBER	DESCRIPTION
1	4	M10 - 1.25 x 30	HEX BOLT
2	4	3/8"	CONICAL TOOTHED WASHER

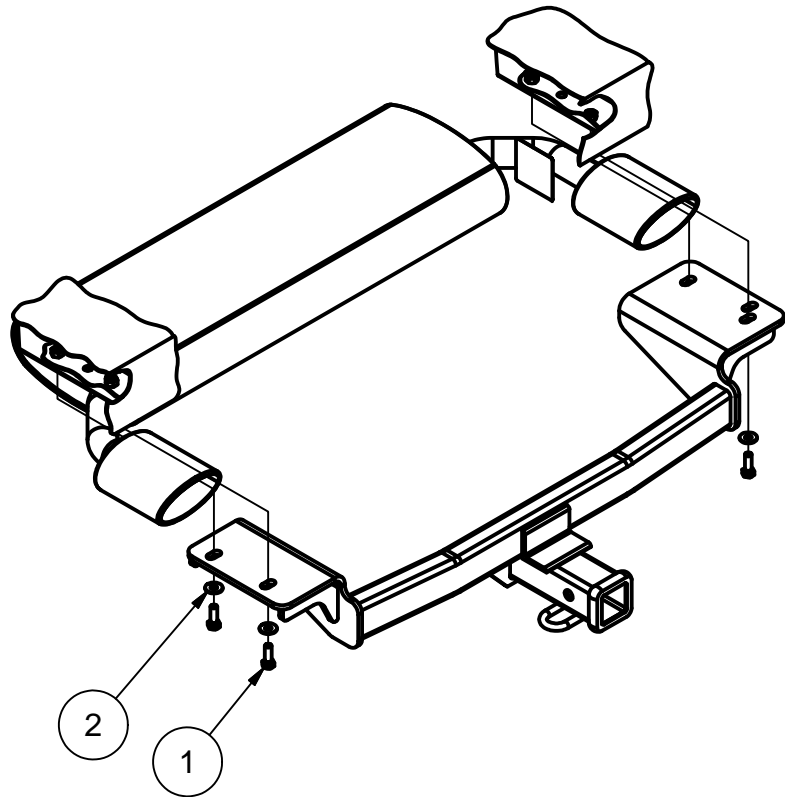

FRONT  
↓  
REAR

1. Locate weldnuts in frame rails (see Weldnut Cleaning Diagram).

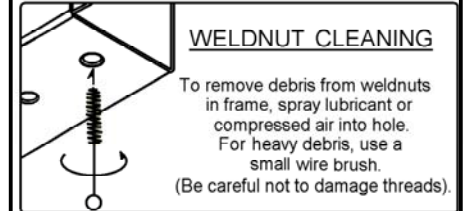
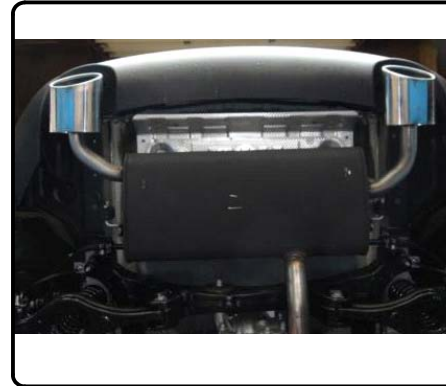

2. Lower exhaust by removing (2) rubber isolators. Support exhaust as needed to prevent damage. (see Rubber Isolator Removal Diagram).

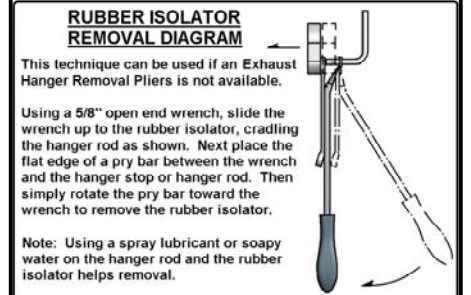
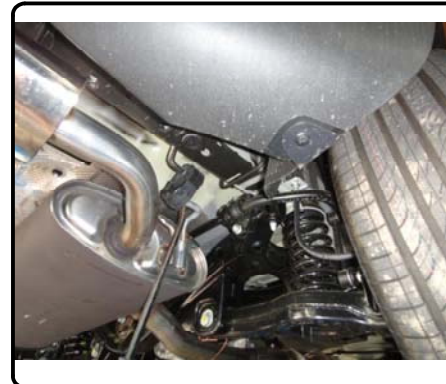

## INSTALLATION WALKTHROUGH:

3. Raise hitch into position aligning holes in side plates with weldnuts in the frame and secure using M10-1.25 x 30mm hex bolts and 3/8" conical toothed washers.

**Note:** It may be necessary to cut or bend rearward lip of heat shield in order to raise hitch into position.



4. Torque all M10 fasteners to 37 ft-lbs.



5. Raise exhaust back into position.



Installation is complete.



13120

2011-Present KIA SPORTAGE / HYUNDAI TUCSON

GROSS LOAD CAPACITY WHEN USED AS A WEIGHT CARRYING HITCH: 3500 LBS. TRAILER WEIGHT & 525 LBS. TONGUE WEIGHT.  
 GROSS LOAD CAPACITY WHEN USED AS A WEIGHT DISTRIBUTION HITCH: 5250 LBS. TRAILER WEIGHT & 525 LBS. TONGUE WEIGHT

\*\*\*DO NOT EXCEED VEHICLE MANUFACTURER'S RECOMMENDED TOWING CAPACITY.\*\*\*

Parts List			
ITEM	QTY	PART NUMBER	DESCRIPTION
1	4	M10 - 1.25 x 30	HEX BOLT
2	4	3/8"	CONICAL TOOTHED WASHER

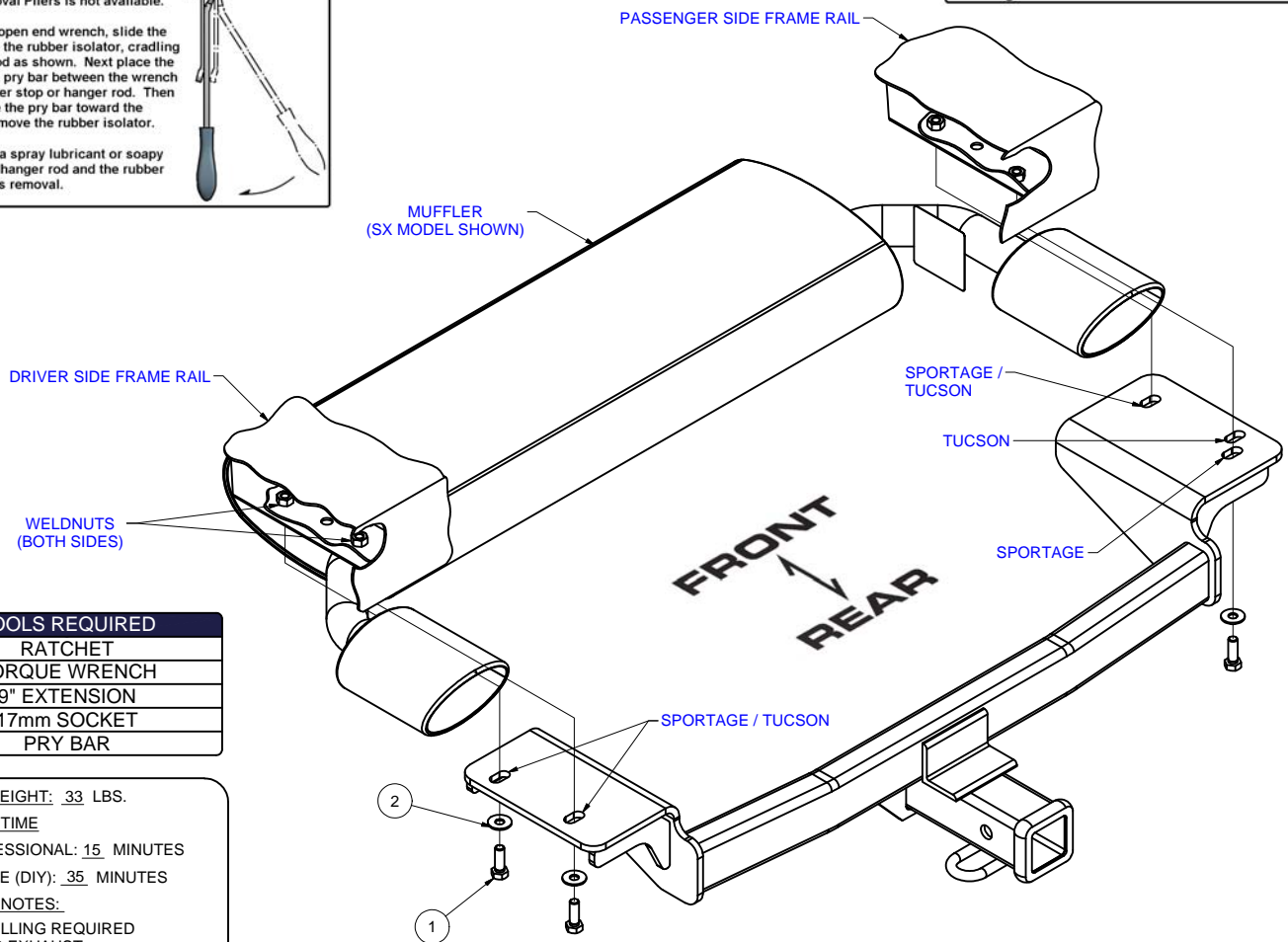
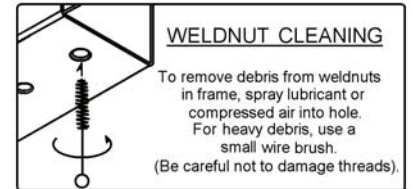
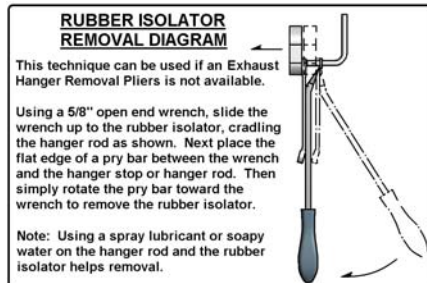

TOOLS REQUIRED
RATCHET
TORQUE WRENCH
9" EXTENSION
17mm SOCKET
PRY BAR

HITCH WEIGHT: 33 LBS.

**INSTALL TIME**

PROFESSIONAL: 15 MINUTES

NOVICE (DIY): 35 MINUTES

**INSTALL NOTES:**

- NO DRILLING REQUIRED
- LOWER EXHAUST

## INSTALLATION STEPS

1. Locate weldnuts in frame rails (See Weldnut Cleaning Diagram).
2. Lower exhaust by removing (2) rubber isolators, support exhaust as needed to prevent damaging (See Rubber Isolator Removal Diagram).
3. Raise hitch into position, aligning holes in side plates with weldnuts in the frame and secure using M10-1.25 x 30mm hex bolts and 3/8" conical toothed washers.  
**Note:** It may be necessary to cut or bend rearward lip of heat shield in order to raise hitch into position.
4. Torque all M10 fasteners to 37 ft-lbs.
5. Raise exhaust back into position.

PERIODICALLY CHECK THIS RECEIVER HITCH TO ENSURE THAT ALL FASTENERS ARE TIGHT AND THAT ALL STRUCTURAL COMPONENTS ARE SOUND.

Curt Manufacturing LLC., warrants this product to be free of defects in material and/or workmanship at the time of retail purchase by the original purchaser. If the product is found to be defective, Curt Manufacturing LLC., may repair or replace the product, at their option, when the product is returned, prepaid, with proof of purchase. Alteration to, misuse of, or improper installation of this product voids the warranty. Curt Manufacturing LLC.'s liability is limited to repair or replacement of products found to be defective, and specifically excludes liability for incidental or consequential loss or damage.