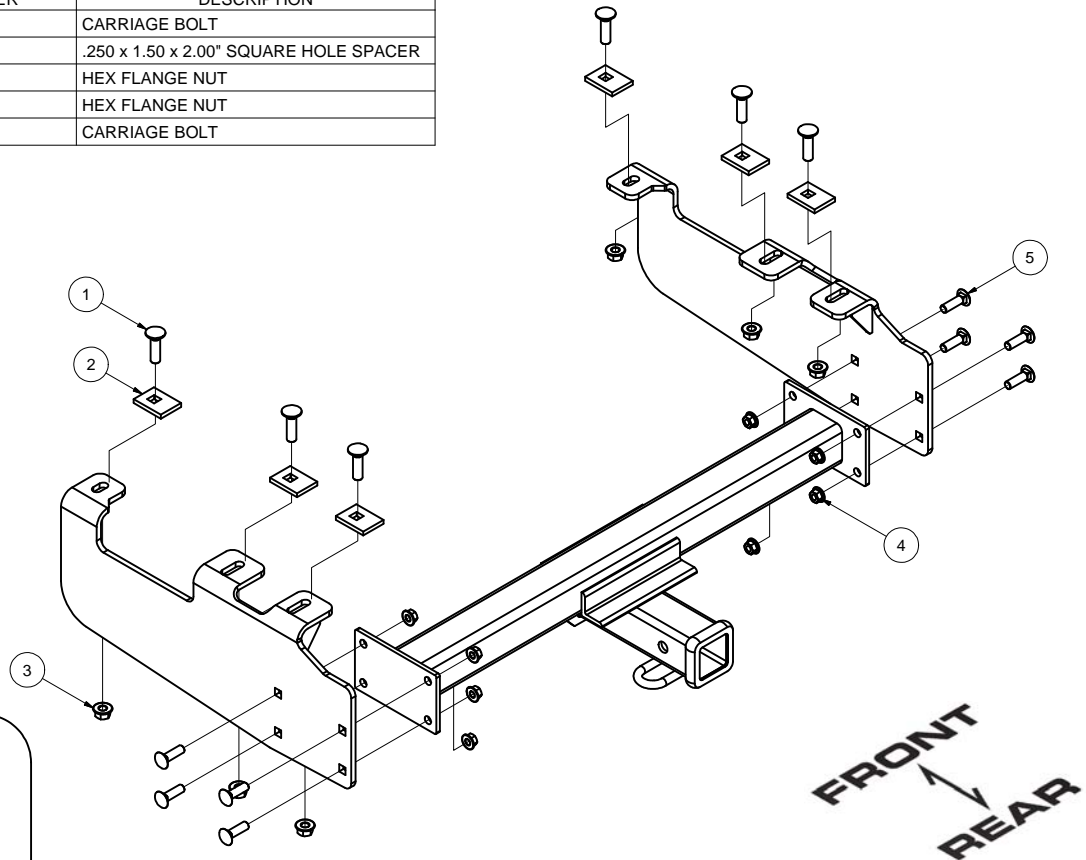

**13099****1963-1996 FORD TRUCKS (ALL FULL SIZE, OLD STYLE ONLY)  
1970-2000 CHEVROLET & GMC PICKUP (FULL SIZE WITH 10" STEP BUMPER)****GROSS LOAD CAPACITY WHEN USED AS A WEIGHT CARRYING HITCH: 6,000 LBS. TRAILER WEIGHT & 600 LBS. TONGUE WEIGHT.  
GROSS LOAD CAPACITY WHEN USED AS A WEIGHT DISTRIBUTION HITCH: 10,000 LBS. TRAILER WEIGHT & 1,000 LBS. TONGUE WEIGHT****\*\*\*DO NOT EXCEED VEHICLE MANUFACTURER'S RECOMMENDED TOWING CAPACITY.\*\*\***

Parts List			
ITEM	QTY	PART NUMBER	DESCRIPTION
1	6	1/2-13 x 1 3/4	CARRIAGE BOLT
2	6	CM-SP1	.250 x 1.50 x 2.00" SQUARE HOLE SPACER
3	6	HFN 1213	HEX FLANGE NUT
4	8	7/16-14	HEX FLANGE NUT
5	8	7/16-14 x 1 1/2	CARRIAGE BOLT

HITCH WEIGHT: 58 LBS.INSTALL TIME: 40 MINUTES

INSTALL NOTES:

**DRILLING REQUIRED****INSTALLATION STEPS**

- 1) Remove spare tire from vehicle.

**Note:** To retain under box tire storage, spare tire carrier will have to be relocated and/or modified.

**Note:** On some Ford Pickup models equipped with a 16" spare tire, it will be necessary to adjust spare tire cradle to retain under vehicle tire storage after hitch is installed.

- 2) Measure vehicle frame width. For 34" frames, position side bracket with mounting flanges pointing inboard. For 38" frames, position bracket with mounting flanges outboard.
- 3) Lift bracket into position, placing rear most mounting tab at end of vehicle frame. Clamp bracket into frame.
- 4) Using slotted holes in bracket as a guide, **drill six, 17/32" diameter holes in frame**. May want to start with smaller bit and work up to 17/32.  
**Note:** In some cases, it may be possible to use existing holes in frame.
- 5) Install side bracket mounting fasteners as shown, placing spacers inside frame. Do not tighten at this time.
- 6) Install cross-tube assembly into side brackets. Install 7/16" x 1 1/2" carriage bolts and 7/16" flange nuts.
- 7) Torque all 1/2" fasteners to 75 lb.-ft. and all 7/16" fasteners to 50 lb.-ft.

PERIODICALLY CHECK THIS RECEIVER HITCH TO ENSURE THAT ALL FASTENERS ARE TIGHT AND THAT ALL STRUCTURAL COMPONENTS ARE SOUND.

Curt Manufacturing Inc., warrants this product to be free of defects in material and/or workmanship at the time of retail purchase by the original purchaser. If the product is found to be defective, Curt Manufacturing Inc., may repair or replace the product, at their option, when the product is returned, prepaid, with proof of purchase. Alteration to, misuse of, or improper installation of this product voids the warranty. Curt Manufacturing Inc.'s liability is limited to repair or replacement of products found to be defective, and specifically excludes liability for incidental or consequential loss or damage.