

GROSS LOAD CAPACITY WHEN USED AS A WEIGHT CARRYING HITCH: 5,000 LBS. TRAILER WEIGHT & 500 LBS. TONGUE WEIGHT.  
GROSS LOAD CAPACITY WHEN USED AS A WEIGHT DISTRIBUTION HITCH: 6,000 LBS. TRAILER WEIGHT & 600 LBS. TONGUE WEIGHT

\*\*\*DO NOT EXCEED VEHICLE MANUFACTURER'S RECOMMENDED TOWING CAPACITY.\*\*\*

Parts List				
ITEM	QTY	PART NUMBER	DESCRIPTION	
1	1	1/2"	FISHWIRE TOOL	
2	8	M12-1.75 x 40mm	HEX TAP BOLT	
3	8	HFN 1213	HEX FLANGE NUT	
4	2	1/2-13 x 1 3/4	HEX TAP BOLT	
5	6	CM-SP1	.250 x 1.50 x 2.00" SQUARE HOLE SPACER	
6	2	CM-SP8	.188 x 1.25 x 1.50" ROUND HOLE SPACER	
7	6	1/2"	WASHER	
8	8	1/2"	LOCK WASHER	
9	6	1/2-13 x 1 3/4	CARRIAGE BOLT	

FRONT  
↑  
↓  
REAR

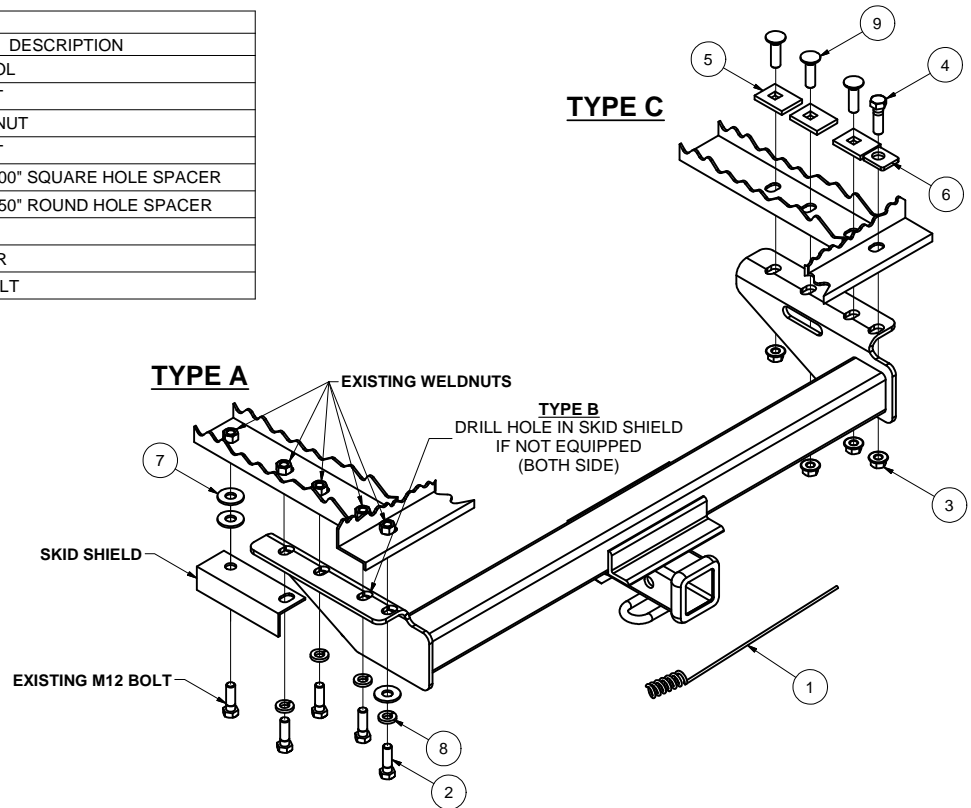

HITCH WEIGHT: 31 LBS.

INSTALL TIME: 30 MINUTES

INSTALL NOTES:

DRILLING MAY BE REQUIRED

## INSTALLATION STEPS

- Remove all but a thin layer of undercoating from attaching surfaces. Also, grind or chisel off small aluminum rivet heads if present on attaching surface. This will ensure side brackets will sit flat against the frame.
- Type A -** For vehicles equipped with frame mounted, closed sided, steel skid shield:

  - Remove the rear skid shield mounting bolt and loosen the forward skid shield mounting bolt on each side so that the skid shield is lowered about 1/4". **NOTE: DO NOT** remove the forward mounting bolt at this time or the skid shield will come off.
  - Raise the hitch into position, putting the receiver flange between the frame and the skid shield.
  - Install four M12 bolts and conical washers on each side as shown. (fishwire blocks and spacers through end of frame rail if weld nuts are not present, may require loosening of bumper bolts)
  - Remove the forward skid shield mounting bolts. Place two 1/2" flat washers as spacers between the frame and the skid shield and reinstall the existing M12 fastener.

**- Type B -** 1997 and newer vehicles with frame mounted, closed sided, steel skid shield:

  - Remove the rear skid shield bolts on both side, and drill hole through skid shield.  
**NOTE:** be careful not to damage weld nuts in frame rails.
  - Raise hitch into position placing hitch over the skid shield flanges and install the existing (4) M12 fasteners.

**- Type C -** For vehicles equipped with frame mounted tow hook bracket on driver's side:

  - Remove the tow hook and the tow hook bracket. Mount the driver and passenger sides as shown.

**- Type D -** For vehicles NOT equipped with frame mounted, closed sided, steel skid shield or frame mounted tow hook:

  - Fishwire the square hole spacers, round spacers and the 1/2" X 1 3/4" carriage bolts through the end of the frame and into existing holes. Leave the fishwires attached to the carriage bolts until the 1/2" Flange Nuts are installed. This allows the bolts to be pulled through the receiver after it has been positioned around the fuel tank.  
**NOTE:** Removal of bumper may ease the fishwiring process
- Torque all 1/2" fasteners to 75 lb.-ft. and all M12 fasteners to 68 lb.-ft.

PERIODICALLY CHECK THIS RECEIVER HITCH TO ENSURE THAT ALL FASTENERS ARE TIGHT AND THAT ALL STRUCTURAL COMPONENTS ARE SOUND.

Curt Manufacturing Inc., warrants this product to be free of defects in material and/or workmanship at the time of retail purchase by the original purchaser. If the product is found to be defective, Curt Manufacturing Inc., may repair or replace the product, at their option, when the product is returned, prepaid, with proof of purchase. Alteration to, misuse of, or improper installation of this product voids the warranty. Curt Manufacturing Inc.'s liability is limited to repair or replacement of products found to be defective, and specifically excludes liability for incidental or consequential loss or damage.