



# 13065 INSTALLATION INSTRUCTIONS



Safety glasses should be worn at all times while installing this product.

YEARS: 2011

MAKE: JEEP

MODEL: GRAND CHEROKEE

STYLE: SUV

**WARNING: NEVER EXCEED YOUR VEHICLE MANUFACTURER'S RECOMMENDED TOWING CAPACITY**

**WEIGHT CARRYING:**  
TRAILER WEIGHT: 5,000 LBS.  
TONGUE WEIGHT: 500 LBS.

**WEIGHT DISTRIBUTION:**  
TRAILER WEIGHT: 7,500 LBS.  
TONGUE WEIGHT: 750 LBS.

**INSTALLATION TIME: 10 MIN.**

THE INSTALL TIME LISTED IS FOR PROFESSIONAL INSTALLERS. IF YOU ARE HESITANT TO UNDERTAKE THIS TASK ON YOUR OWN, CONTACT AN AUTHORIZED CURT INSTALLER FOR ADDITIONAL ASSISTANCE.

**INSTALLATION TIPS:**

1. BEFORE YOU BEGIN INSTALLATION, READ ALL INSTRUCTIONS THOROUGHLY.
2. TO EASE INSTALLATION, 2 PEOPLE MAY BE REQUIRED.
3. USING PROPER TOOLS WILL GREATLY IMPROVE THE QUALITY OF THE INSTALL AND REDUCE THE TIME REQUIRED.

**VEHICLE PHOTO:**





REPRESENTATIVE PHOTO

**INSTALLATION REQUIRES:**

 RATCHET	 21mm SOCKET	 TORQUE WRENCH
 UTILITY KNIFE		

**LEVEL OF DIFFICULTY: EASY**

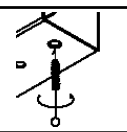
EASY	MODERATE	HARD
	NO DRILLING REQUIRED	
	TRIMMING OF EXCESS CALK MAY BE REQUIRED	
	WELDNUT CLEANING MAY BE REQUIRED	

**HITCH ILLUSTRATION:**

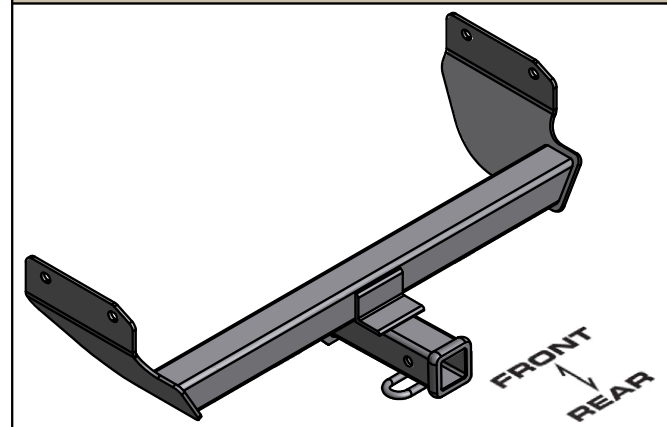

MAKE SURE YOUR HITCH MATCHES

**PERIODICALLY CHECK THIS RECEIVER HITCH TO ENSURE ALL FASTENERS ARE TIGHT AND ALL STRUCTURAL COMPONENTS ARE SOUND**

CURT Manufacturing Inc. warrants this product to be free of defects in material and/or workmanship at the time of retail purchase by the original purchaser. If the product is found to be defective, Curt Manufacturing Inc. may repair or replace the product at their option, when the product is returned, prepaid, with proof of purchase. Alteration to, misuse of, or improper installation of this product voids the warranty. Curt Manufacturing Inc.'s liability is limited to repair or replacement of products found to be defective, and specifically excludes liability for incidental or consequential loss or damage.

## INSTALLATION WALKTHROUGH:

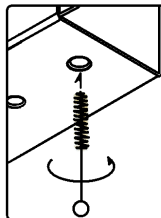
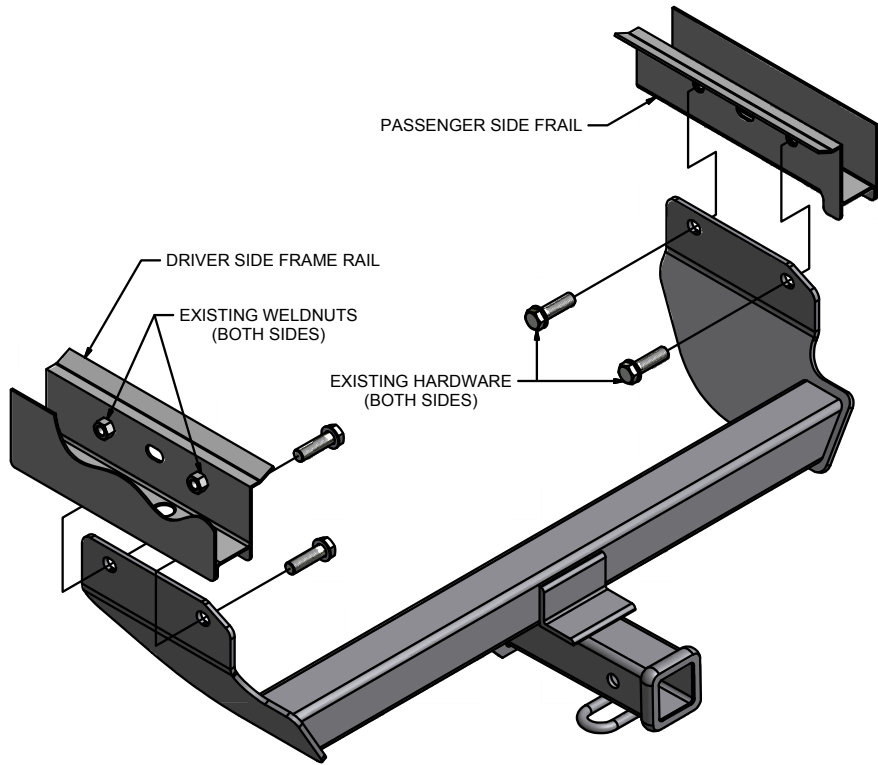

### WELDNUT CLEANING

To remove debris from weldnuts in frame, spray lubricant or compressed air into hole. For heavy debris, use a small wire brush. (Be careful not to damage threads).

FRONT  
↓  
REAR

1. Remove (4) existing M14 bolts. These bolts will be used for hitch installation.

**Note:** If factory tow loop is present you will need to remove it prior to install. Trim excess caulk on vehicle frame rails if it interferes with hitch installation.

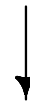
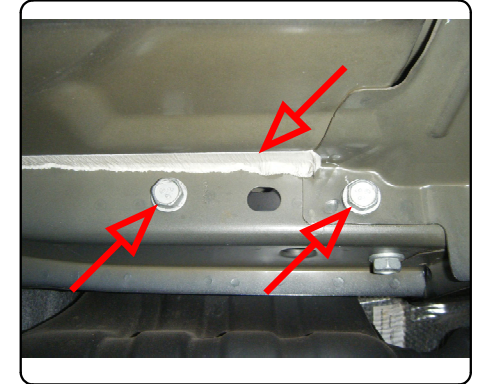

2. Raise hitch into position and reinstall (4) M14 bolts. Torque all M14 hardware to 105 ft-lbs.

Install is complete.



13065

# JEEP GRAND CHEROKEE

GROSS LOAD CAPACITY WHEN USED AS A WEIGHT CARRYING HITCH: 5,000 LBS. TRAILER WEIGHT & 500 LBS. TONGUE WEIGHT.  
GROSS LOAD CAPACITY WHEN USED AS A WEIGHT DISTRIBUTION HITCH: 7,500 LBS. TRAILER WEIGHT & 750 LBS. TONGUE WEIGHT

\*\*\*DO NOT EXCEED VEHICLE MANUFACTURER'S RECOMMENDED TOWING CAPACITY.\*\*\*

## INSTALLED HITCH POSITION

### TOOLS REQUIRED

RATCHET
21mm SOCKET
TORQUE WRENCH

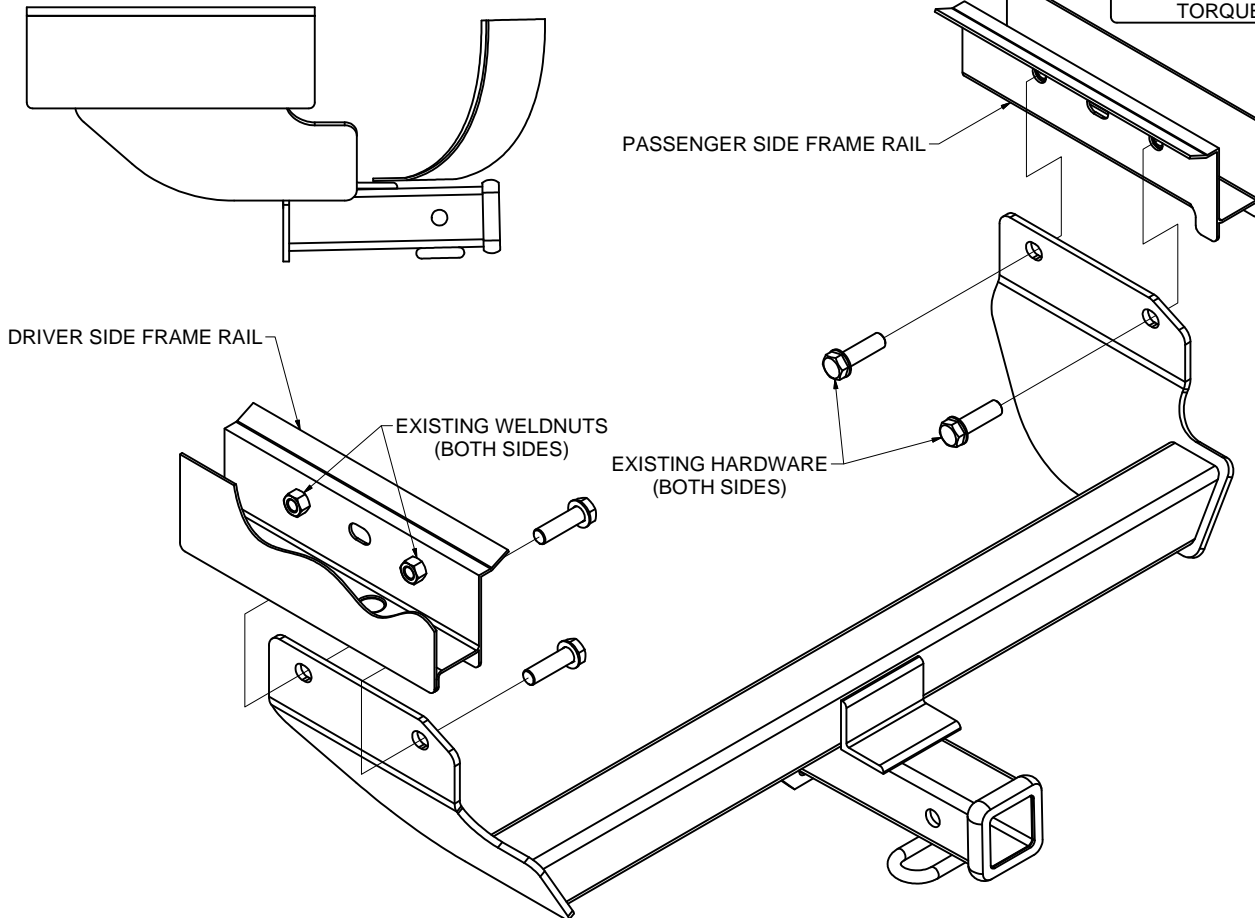

HITCH WEIGHT: 33 LBS.

### INSTALL TIME

PROFESSIONAL: 10 MINUTES

NOVICE (DIY): 20 MINUTES

### INSTALL NOTES:

- NO DRILLING REQUIRED

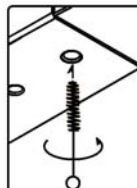

### WELDNUT CLEANING

To remove debris from weldnuts in frame, spray lubricant or compressed air into hole. For heavy debris, use a small wire brush. (Be careful not to damage threads).

FRONT  
↑  
REAR

## INSTALLATION STEPS

**Note:** If factory tow loop is present you will need to remove it prior to install.

1. Remove (4) existing M14 bolts. These bolts will be used for hitch installation.
2. Raise hitch into position and reinstall (4) M14 bolts. Note: Trim excess caulk on vehicle frame rails if it interferes with hitch installation.
3. Tighten all M14 hardware to 105 ft-lbs.

PERIODICALLY CHECK THIS RECEIVER HITCH TO ENSURE THAT ALL FASTENERS ARE TIGHT AND THAT ALL STRUCTURAL COMPONENTS ARE SOUND.

Curt Manufacturing Inc., warrants this product to be free of defects in material and/or workmanship at the time of retail purchase by the original purchaser. If the product is found to be defective, Curt Manufacturing Inc., may repair or replace the product, at their option, when the product is returned, prepaid, with proof of purchase. Alteration to, misuse of, or improper installation of this product voids the warranty. Curt Manufacturing Inc.'s liability is limited to repair or replacement of products found to be defective, and specifically excludes liability for incidental or consequential loss or damage.