

13053

75-06 FORD E-150, E-250, & E-350

GROSS LOAD CAPACITY WHEN USED AS A WEIGHT CARRYING HITCH: 5,000 LBS. TRAILER WEIGHT & 500 LBS. TONGUE WEIGHT.
GROSS LOAD CAPACITY WHEN USED AS A WEIGHT DISTRIBUTION HITCH: 7,500 LBS. TRAILER WEIGHT & 750 LBS. TONGUE WEIGHT

*****DO NOT EXCEED VEHICLE MANUFACTURER'S RECOMMENDED TOWING CAPACITY.*****

Parts List			
ITEM	QTY	PART NUMBER	DESCRIPTION
1	14	FW12	FW, 12, ZP
2	4	1/2-13 x 1 3/4	HEX BOLT
3	2	1/2-13 x 1 3/4	CARRIAGE BOLT
4	6	CM-SP16	.250 x 1.50 x 2.00" ROUND HOLE SPACER
5	2	1/2"	FENDER WASHER
6	4	CM-SP12	.250 x 1.00 x 2.00" SQUARE HOLE SPACER
7	8	HFN 1213	HEX FLANGE NUT
8	8	CM-SP38	1/2" WEDGE SPACER
9	4	1/2-13 x 2 1/4	HEX BOLT

HARDWARE USAGE WILL VARY WITH APPLICATION

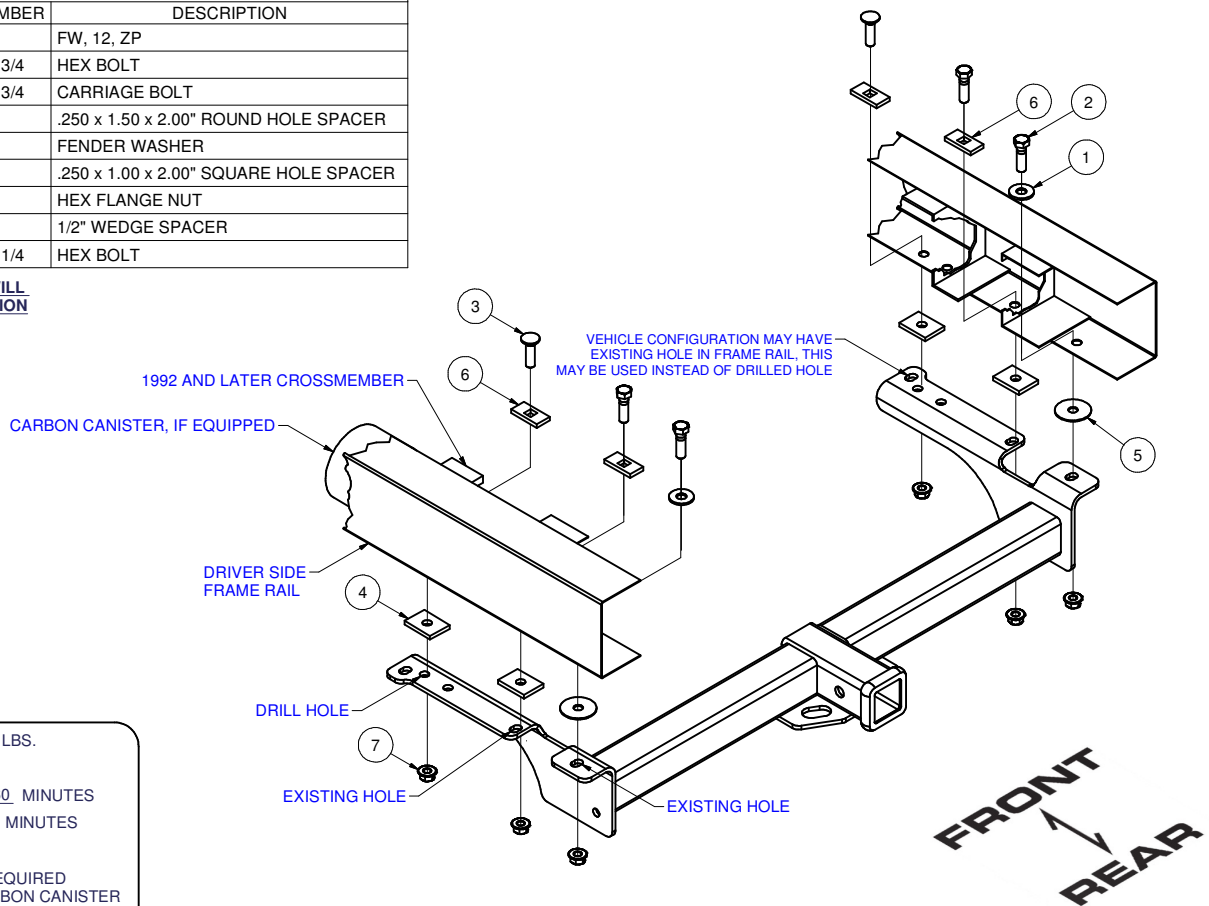

HITCH WEIGHT: 33 LBS.

INSTALL TIME

PROFESSIONAL: 60 MINUTES

NOVICE (DIY): 120 MINUTES

INSTALL NOTES:

- DRILLING REQUIRED
- LOWER CARBON CANISTER
- LOWER SPARE TIRE

INSTALLATION STEPS

1. If present, lower carbon canister from driver's side frame rail. Also lower spare tire.
NOTE: RELOCATION OF SPARE TIRE IS NOT REQUIRED. TIRE MAY BE REPOSITION FORWARD TO AVOID CONTACT WITH HITCH
2. Remove frame undercoating from attaching surfaces and disconnect factory installed optional driver's side trailer wiring connection from bumper.
3. Position hitch on vehicle by lining up existing holes and loosely install hardware as shown.
4. Using hitch as a template, drill a 1/2" hole in each frame rail and install hardware as shown.
5. Reinstall factory trailer wiring connection around hitch.
6. Raise spare tire and carbon canister. Check for clearance between differential and brake lines.
7. Tighten fasteners to 75 lb.-ft.

PRE 1992 MODELS - SEE FIGURES 3, 4, & 5

NOTE: ON SOME MODELS, TAIL PIPE AND/OR TAIL PIPE BRACKET MAY HAVE TO BE RELOCATED AND/OR MODIFIED.

1. If present, lower carbon canister in driver's side frame rail and remove frame undercoating from attaching surfaces.
2. Center hitch on vehicle and position so that the frame crossmember rivets fit into the notch in the side plates.
3. Using hitch as a template, drill three (3) holes per side through the frame with a 1/2" drill bit. Be careful not to drill into the carbon canister.
4. Install fasteners as shown and tighten to 75 lb.-ft.

PERIODICALLY CHECK THIS RECEIVER HITCH TO ENSURE THAT ALL FASTENERS ARE TIGHT AND THAT ALL STRUCTURAL COMPONENTS ARE SOUND.

Curt Manufacturing Inc., warrants this product to be free of defects in material and/or workmanship at the time of retail purchase by the original purchaser. If the product is found to be defective, Curt Manufacturing Inc., may repair or replace the product, at their option, when the product is returned, prepaid, with proof of purchase. Alteration to, misuse of, or improper installation of this product voids the warranty. Curt Manufacturing Inc.'s liability is limited to repair or replacement of products found to be defective, and specifically excludes liability for incidental or consequential loss or damage.

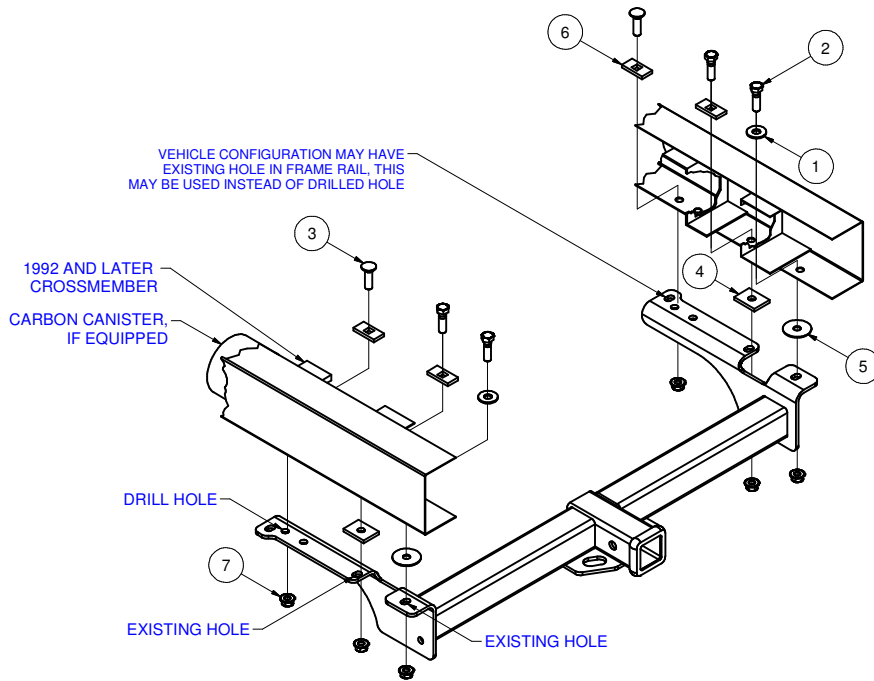

FIGURE 2 - 1992 & LATER E-350 MODELS

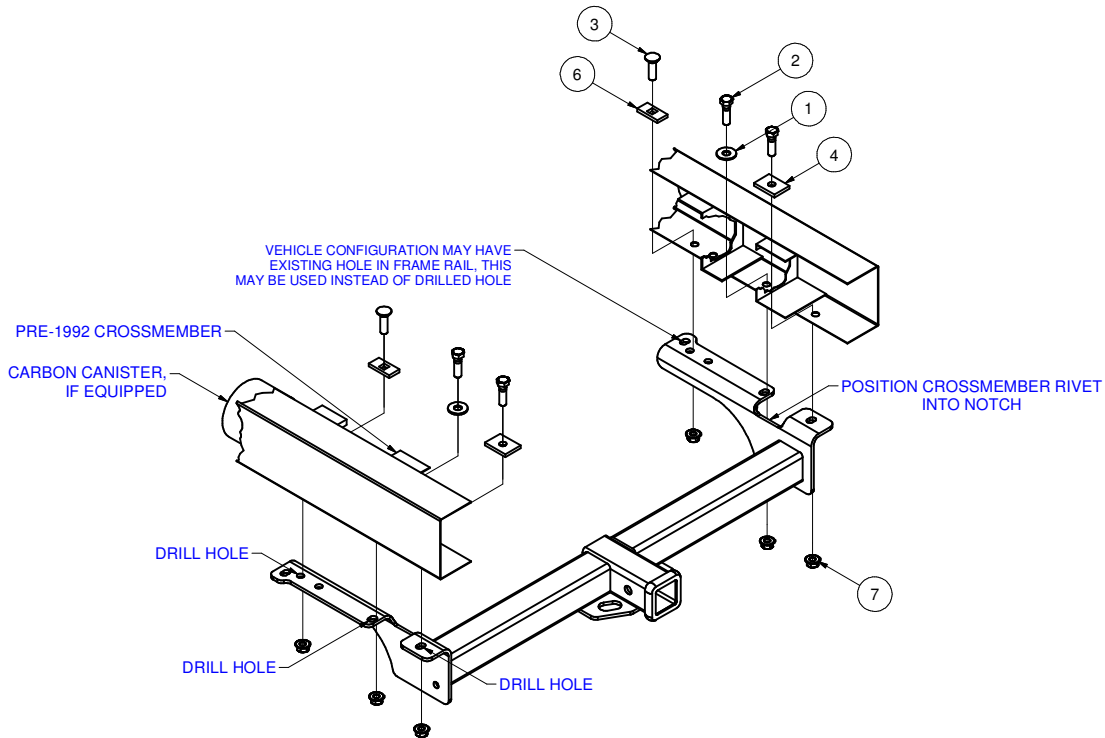

FIGURE 3 - PRE-1992 E-150 & E-250 MODELS

PERIODICALLY CHECK THIS RECEIVER HITCH TO ENSURE THAT ALL FASTENERS ARE TIGHT AND THAT ALL STRUCTURAL COMPONENTS ARE SOUND.

Curt Manufacturing Inc., warrants this product to be free of defects in material and/or workmanship at the time of retail purchase by the original purchaser. If the product is found to be defective, Curt Manufacturing Inc., may repair or replace the product, at their option, when the product is returned, prepaid, with proof of purchase. Alteration to, misuse of, or improper installation of this product voids the warranty. Curt Manufacturing Inc.'s liability is limited to repair or replacement of products found to be defective, and specifically excludes liability for incidental or consequential loss or damage.

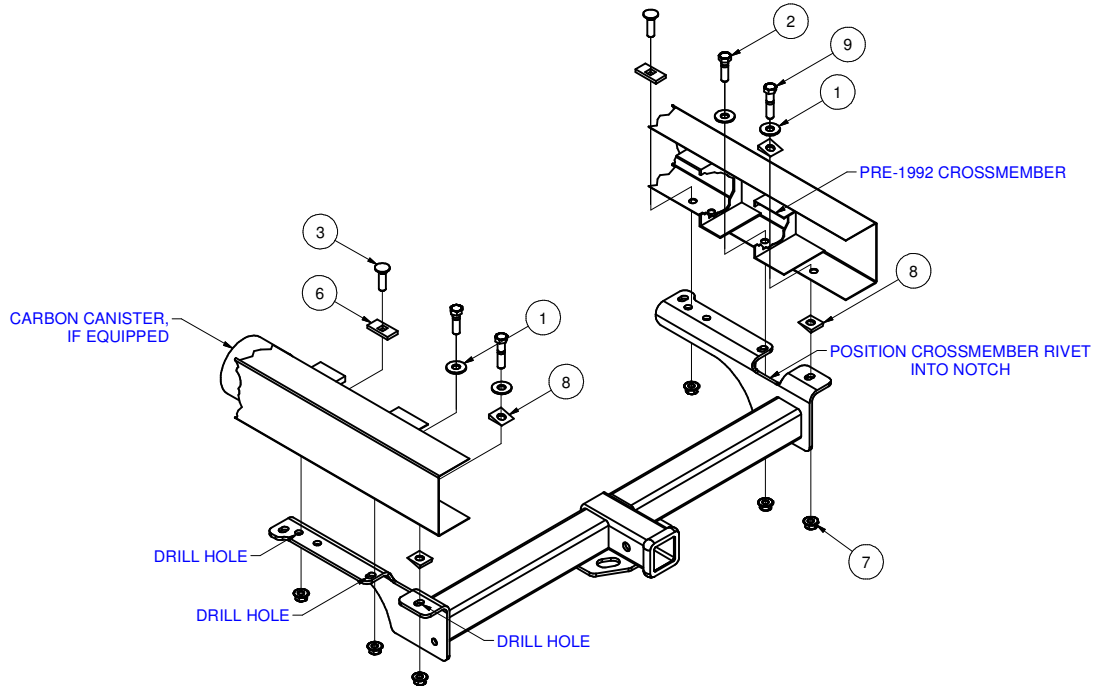

FIGURE 4 - PRE-1992 E-350 MODELS

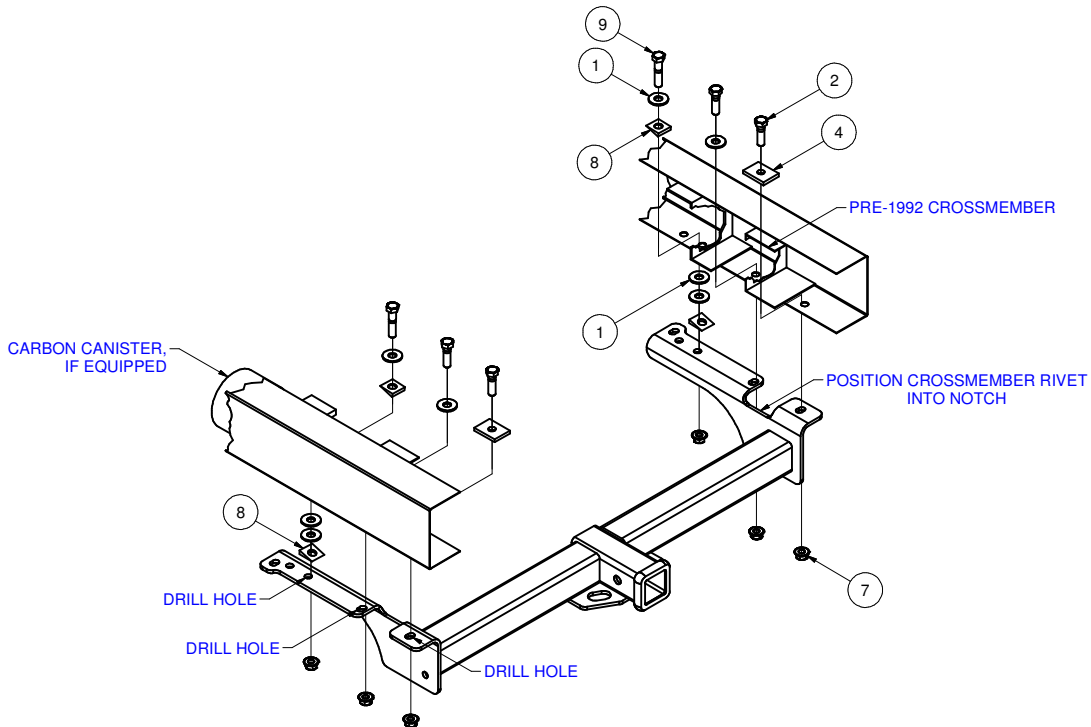

FIGURE 5 - PRE-1992 124" WHEELBASE MODELS

PERIODICALLY CHECK THIS RECEIVER HITCH TO ENSURE THAT ALL FASTENERS ARE TIGHT AND THAT ALL STRUCTURAL COMPONENTS ARE SOUND.

Curt Manufacturing Inc., warrants this product to be free of defects in material and/or workmanship at the time of retail purchase by the original purchaser. If the product is found to be defective, Curt Manufacturing Inc., may repair or replace the product, at their option, when the product is returned, prepaid, with proof of purchase. Alteration to, misuse of, or improper installation of this product voids the warranty. Curt Manufacturing Inc.'s liability is limited to repair or replacement of products found to be defective, and specifically excludes liability for incidental or consequential loss or damage.