

13050

CADILLAC SRX

GROSS LOAD CAPACITY WHEN USED AS A WEIGHT CARRYING HITCH: 3,500 LBS. TRAILER WEIGHT & 350 LBS. TONGUE WEIGHT.
 GROSS LOAD CAPACITY WHEN USED AS A WEIGHT DISTRIBUTION HITCH: 5,000 LBS. TRAILER WEIGHT & 500 LBS. TONGUE WEIGHT

DO NOT EXCEED VEHICLE MANUFACTURER'S RECOMMENDED TOWING CAPACITY.

| Parts List | | | |
|------------|-----|-----------------|--|
| ITEM | QTY | PART NUMBER | DESCRIPTION |
| 1 | 6 | M12-1.75 x 40mm | HEX BOLT |
| 2 | 6 | 1/2" | CONICAL TOOTHED WASHER |
| 3 | 1 | CM-SP12 | .250 x 1.00 x 2.00" SQUARE HOLE SPACER |

FRONT
 REAR

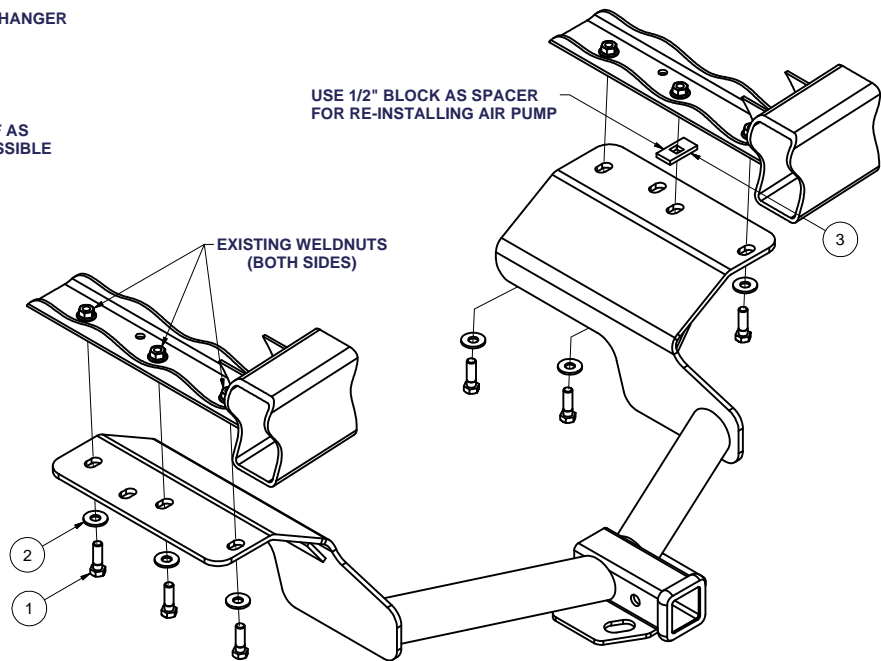
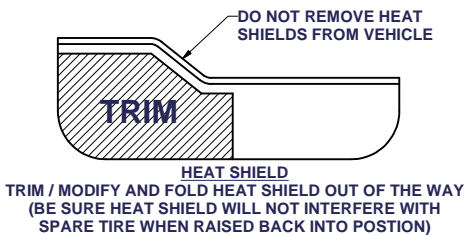
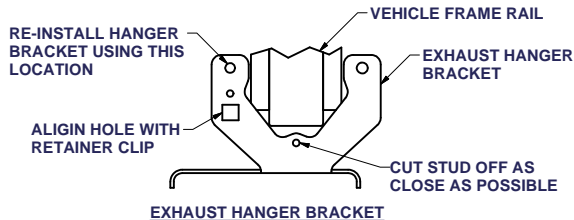
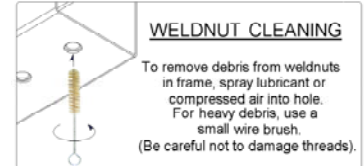

HITCH WEIGHT: 51 LBS.

INSTALL TIME

PROFESSIONAL: 120 MINUTES

NOVICE (DIY): 240 MINUTES

INSTALL NOTES:

- NO DRILLING REQUIRED
- LOWER SPARE AND EXHAUST
- HEAT SHIELD MODIFICATION
- TRIM BUMPER STUDS (2)

INSTALLATION STEPS

- 1) Lower spare tire
- 2) Disconnect rubber exhaust hanger brackets, (3) Each side (two forward and one rearward of muffler).
- 3) Remove (3) nuts and retaining clip from each of the rearmost exhaust hanger brackets.
- 4) If necessary, trim/modify heat shields for ease of installation as shown above.
- 5) Carefully cut off lower stud, each side, as close to vehicle as possible without removing bracket.
****DO NOT CUT OFF (2) UPPER STUDS.****
- 6) Re-install exhaust hanger brackets using (2) of the (3) nuts removed in step 3. Hanger bracket must be oriented so that square hole in bracket aligns with retaining clip on vehicle.
- 7) Raise hitch into position, install M12 bolts and 1/2" conical toothed washers as shown.
****Vehicles equipped with air pump mounted on passenger's side frame rail, temporarily remove pump by removing (2) bolts which secure pump to frame. Retain fasteners for reinstallation of pump after hitch is installed.****
- 8) Torque all M12 fasteners to 60 lb-ft.
- 9) Re-connect rubber exhaust hangers, (three places each side). Raise spare tire.

PERIODICALLY CHECK THIS RECEIVER HITCH TO ENSURE THAT ALL FASTENERS ARE TIGHT AND THAT ALL STRUCTURAL COMPONENTS ARE SOUND.

Curt Manufacturing Inc., warrants this product to be free of defects in material and/or workmanship at the time of retail purchase by the original purchaser. If the product is found to be defective, Curt Manufacturing Inc., may repair or replace the product, at their option, when the product is returned, prepaid, with proof of purchase. Alteration to, misuse of, or improper installation of this product voids the warranty. Curt Manufacturing Inc.'s liability is limited to repair or replacement of products found to be defective, and specifically excludes liability for incidental or consequential loss or damage.