

# 13042 / 78133 / RRH13042

1988 - 2000 CHEVY/GMC ALL FULL SIZE W/ DUAL EXHAUST (OLD STYLE)  
 1988 - 1998 CHEVY/GMC 1/2 TON W/ 6' & 8' BED (OLD STYLE)  
 1988 - 2000 CHEVY/GMC 3/4 & 1 TON CLASSIC, 6' & 8' (OLD STYLE)  
 1992 - 1998 CHEVY/GMC 4 DR CREW CAB ONLY

**GROSS LOAD CAPACITY WHEN USED AS A WEIGHT CARRYING HITCH: 6,000 LBS. TRAILER WEIGHT & 600 LBS. TONGUE WEIGHT.**  
**GROSS LOAD CAPACITY WHEN USED AS A WEIGHT DISTRIBUTION HITCH: 10,000 LBS. TRAILER WEIGHT & 1,000 LBS. TONGUE WEIGHT**  
 \*\*\*DO NOT EXCEED VEHICLE MANUFACTURER'S RECOMMENDED TOWING CAPACITY.\*\*\*

Parts List				
ITEM	QTY	PART NUMBER	DESCRIPTION	
1	4	1/2 - 13 x 2"	CARRIAGE BOLT	
2	6	CM-SP1	.250 x 1.50 x 2.00" SQUARE HOLE SPACER	
3	4	HFN 1213	HEX FLANGE NUT	
4	2	M12 - 1.75 x 50mm	HEX BOLT	
5	2	M12 - 1.75	HEX NUT	

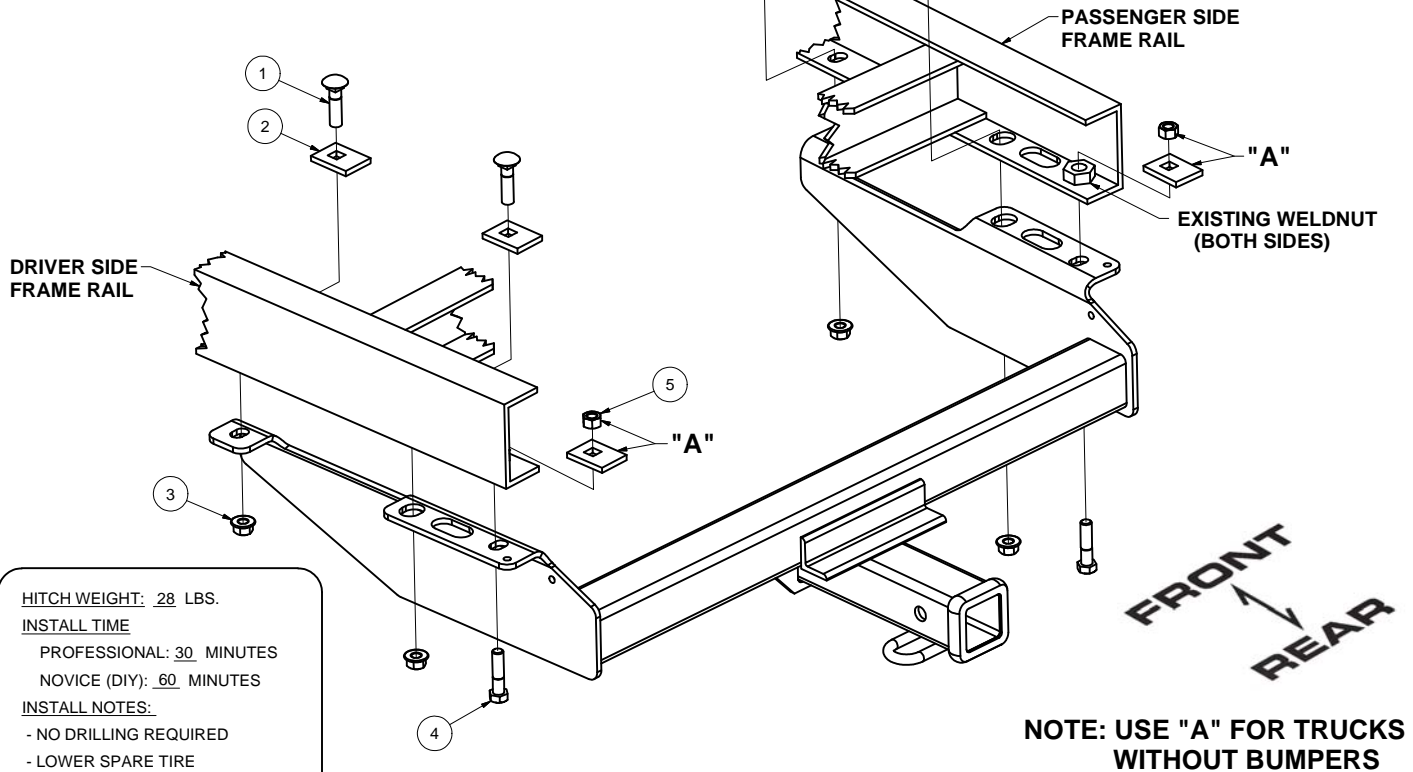
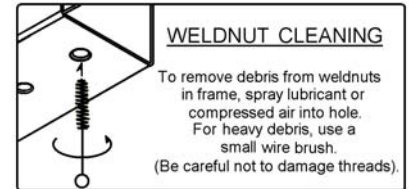

## INSTALLATION STEPS

**NOTE: BEFORE YOU BEGIN TO INSTALL THIS HITCH, LOWER AND REMOVE THE SPARE TIRE FROM ITS STORAGE LOCATION. THIS WILL ALLOW MORE ROOM FOR EASIER HITCH INSTALLATION REINSTALL SPARE TIRE AFTER HITCH IS INSTALLED.**

1. At the end of each truck side frame will be a slot. If the truck is equipped with a GM Factory installed bumper, there will be a 12mm bolt from each frame location. If no bumper is installed, you will only see a slot in each frame end. Use CM-SP1 and M12-1.75 hex nut.
2. Position the hitch assembly up against the bottom of the truck side frame so that the rearmost hole in each hitch frame bracket is aligned with the slots in the end of vehicle frame.
3. Bolt hitch assembly to truck frame at center attachment point using the existing hole in each side frame.
4. Torque all 1/2" fasteners to 75 ft-lbs and M12 fasteners to 59 ft-lbs.
5. Reinstall spare tire when done.

PERIODICALLY CHECK THIS RECEIVER HITCH TO ENSURE THAT ALL FASTENERS ARE TIGHT AND THAT ALL STRUCTURAL COMPONENTS ARE SOUND.

Curt Manufacturing Inc., warrants this product to be free of defects in material and/or workmanship at the time of retail purchase by the original purchaser. If the product is found to be defective, Curt Manufacturing Inc., may repair or replace the product, at their option, when the product is returned, prepaid, with proof of purchase. Alteration to, misuse of, or improper installation of this product voids the warranty. Curt Manufacturing Inc.'s liability is limited to repair or replacement of products found to be defective, and specifically excludes liability for incidental or consequential loss or damage.