

**13016 / RRH13016****78-96 CHEVY / GMC VAN (FULL SIZE)**

**GROSS LOAD CAPACITY WHEN USED AS A WEIGHT CARRYING HITCH: 6,000 LBS. TRAILER WEIGHT & 600 LBS. TONGUE WEIGHT.**  
**GROSS LOAD CAPACITY WHEN USED AS A WEIGHT DISTRIBUTION HITCH: 10,000 LBS. TRAILER WEIGHT & 1,000 LBS. TONGUE WEIGHT**

\*\*\*DO NOT EXCEED VEHICLE MANUFACTURER'S RECOMMENDED TOWING CAPACITY.\*\*\*

Parts List			
ITEM	QTY	PART NUMBER	DESCRIPTION
1	4	3/8"	WASHER
2	2	CM-SP10	.250 x 1.00 x 2.50" SQUARE HOLE SPACER
3	2	HFN 1213	HEX FLANGE NUT
4	2	1/2-13 x 1 3/4	CARRIAGE BOLT
5	1	1/2"	FISHWIRE TOOL

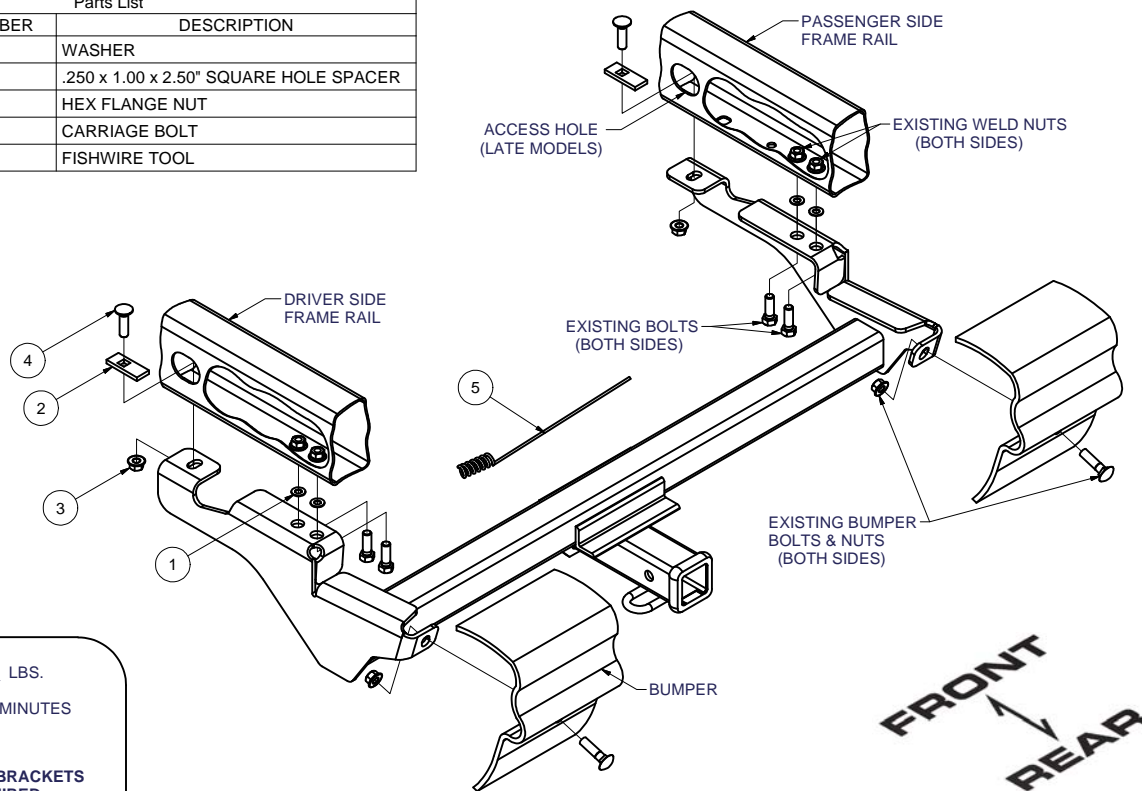

HITCH WEIGHT: 47 LBS.

INSTALL TIME: 45 MINUTES

INSTALL NOTES:

- REMOVE BUMPER BRACKETS
- NO DRILLING REQUIRED

## INSTALLATION STEPS

**IMPORTANT: Read instructions completely before installation.**

**Note:** It may be necessary on some models to remove excess length from the fuel tank strap bolts.

- 1) **Locate bumper brackets** which bolt to bottom of each frame rail and lower of bumper. Remove both brackets, retaining brackets and fasteners. Bumper brackets should be given to vehicle owner for re- installation in the event that receiver is removed.
- 2) **Enlarge existing hole** for forward attachment to 9/16". Fishwire the 1/2" carriage bolts and blocks through opening in outside frame for forward attachment as shown.

**Note:** Early model vehicles have access slot. Late models have round access holes; the fuel tank filler line passes through this hole on drivers side, a tail light wire passes through this hole on the passenger side.

- 3) **Remove undercoating** from attaching surfaces. Bolt receiver to bottom of frame and lower face of bumper using bolts removed in step 1.
- 4) **Install remaining fasteners** as shown. **Note:** 3/8" Flatwashers can be used at rear-most attachment between bumper and hitch if there is any gap.
- 5) **Tighten all fasteners**  
 1/2 grade 5 bolts to 75 lb-ft.  
 3/8 grade 5 bolts to 31 lb-ft

PERIODICALLY CHECK THIS RECEIVER HITCH TO ENSURE THAT ALL FASTENERS ARE TIGHT AND THAT ALL STRUCTURAL COMPONENTS ARE SOUND.

Curt Manufacturing Inc., warrants this product to be free of defects in material and/or workmanship at the time of retail purchase by the original purchaser. If the product is found to be defective, Curt Manufacturing Inc., may repair or replace the product, at their option, when the product is returned, prepaid, with proof of purchase. Alteration to, misuse of, or improper installation of this product voids the warranty. Curt Manufacturing Inc.'s liability is limited to repair or replacement of products found to be defective, and specifically excludes liability for incidental or consequential loss or damage.