



13000 INSTALLATION INSTRUCTIONS



Safety glasses should be worn at all times while installing this product.

YEARS: 2010-CURRENT

MAKE: LINCOLN

MODEL: MKT

STYLE: CROSS OVER

WARNING: NEVER EXCEED YOUR VEHICLE MANUFACTURER'S RECOMMENDED TOWING CAPACITY

WEIGHT CARRYING:
TRAILER WEIGHT: 4,000 LBS.
TONGUE WEIGHT: 400 LBS.

INSTALLATION TIME: 40 MIN.
THE INSTALL TIME LISTED IS FOR PROFESSIONAL INSTALLERS. IF YOU ARE HESITANT TO UNDERTAKE THIS TASK ON YOUR OWN, CONTACT AN AUTHORIZED CURT INSTALLER FOR ADDITIONAL ASSISTANCE.

INSTALLATION TIPS:
1. BEFORE YOU BEGIN INSTALLATION, READ ALL INSTRUCTIONS THOROUGHLY.
2. TO EASE INSTALLATION, 2 PEOPLE MAY BE REQUIRED.
3. USING PROPER TOOLS WILL GREATLY IMPROVE THE QUALITY OF THE INSTALL AND REDUCE THE TIME REQUIRED.



INSTALLATION REQUIRES:

 RATCHET	 18 mm SOCKET	 8 in SOCKET EXTENSION
 TORQUE WRENCH	 PRY BAR	 SPRAY LUBRICANT
 SAFETY GLASSES	 MASKING TAPE	

LEVEL OF DIFFICULTY: HARD

EASY	MODERATE	HARD
	MUST REMOVE (4) REARMOST EXHAUST HANGERS	
	WELDNUT CLEANING MAY BE REQUIRED	

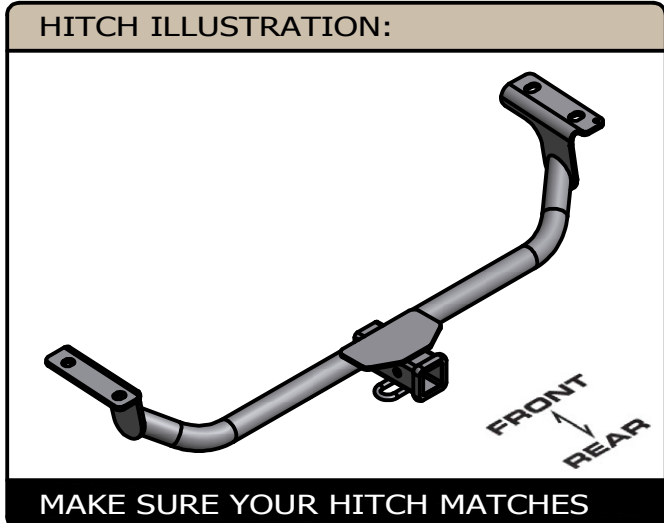

PERIODICALLY CHECK THIS RECEIVER HITCH TO ENSURE ALL FASTENERS ARE TIGHT AND ALL STRUCTURAL COMPONENTS ARE SOUND

CURT Manufacturing Inc. warrants this product to be free of defects in material and/or workmanship at the time of retail purchase by the original purchaser. If the product is found to be defective, Curt Manufacturing Inc. may repair or replace the product at their option, when the product is returned, prepaid, with proof of purchase. Alteration to, misuse of, or improper installation of this product voids the warranty. Curt Manufacturing Inc.'s liability is limited to repair or replacement of products found to be defective, and specifically excludes liability for incidental or consequential loss or damage.

INSTALLATION WALKTHROUGH:

Parts List			
ITEM	QTY	PART NUMBER	DESCRIPTION
1	4	M12-1.75 x 40mm	HEX BOLT
2	4	1/2"	CONICAL TOOTHED WASHER

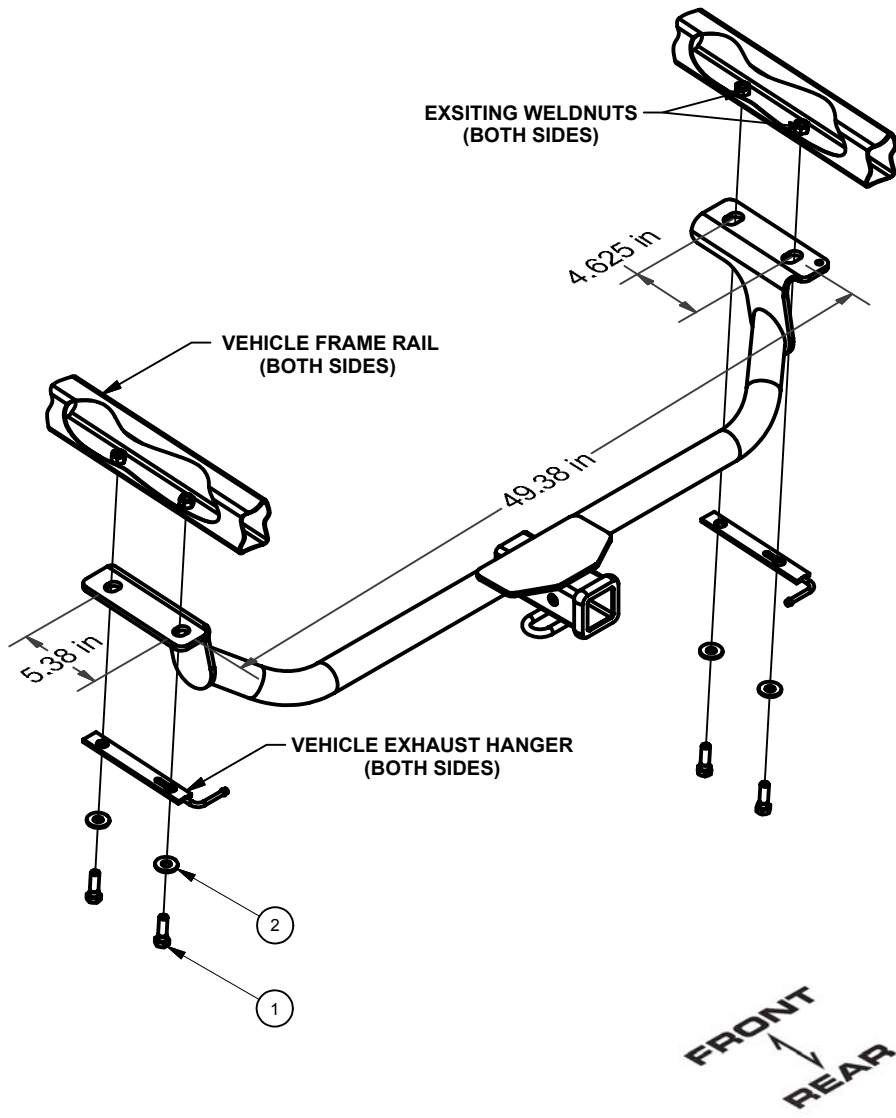

1. Remove (2) center rubber exhaust hangers. (See RUBBER ISOLATOR REMOVAL DIAGRAM) **Note:** Be sure to support exhaust so it does not bend in STEP 2.



RUBBER ISOLATOR REMOVAL DIAGRAM

This technique can be used if an Exhaust Hanger Removal Pliers is not available.

Using a 5/8" open end wrench, slide the wrench up to the rubber isolator, cradling the hanger rod as shown. Next place the flat edge of a pry bar between the wrench and the hanger stop or hanger rod. Then simply rotate the pry bar toward the wrench to remove the rubber isolator.

Note: Using a spray lubricant or soapy water on the hanger rod and the rubber isolator helps removal.

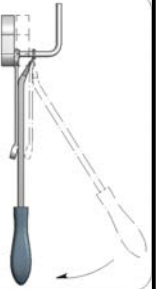

2. Remove (4) M12x1.75 bolts which attach exhaust hangers to the vehicle frame rail. (Two bolts on each exhaust hanger)



INSTALLATION WALKTHROUGH:

3. Place hitch so it is between the exhaust and exhaust hanger which is welded to the exhaust on both sides. Simultaneously raise hitch and exhaust into position.



4. Use included hardware to attach hitch and exhaust hangers to vehicle frame. Leave bolts loose. **Note:** Hitch is sandwiched between frame and exhaust hanger.

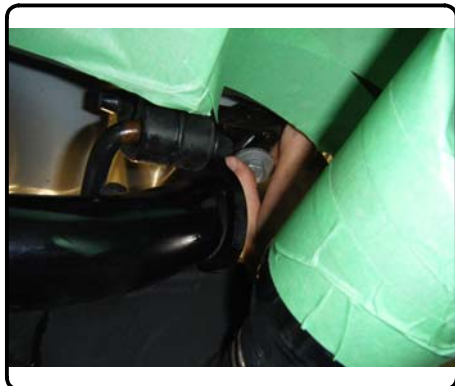
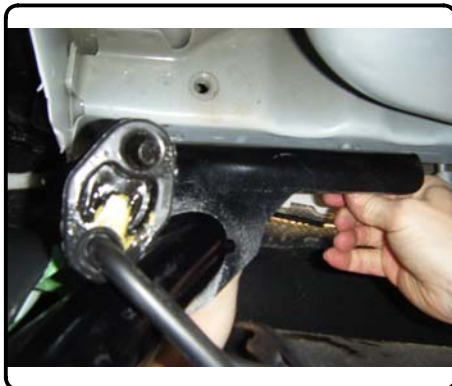

5. Adjust hitch to allow maximum clearance between hitch and exhaust to avoid rattling. Torque all M12x1.75 hardware to 60 ft-lbs.



6. Re-attach (2) center rubber exhaust hangers which were removed in STEP 1. Install is complete.



13000

LINCOLN MKT

GROSS LOAD CAPACITY WHEN USED AS A WEIGHT CARRYING HITCH: 4,000 LBS. TRAILER WEIGHT & 400 LBS. TONGUE WEIGHT.

DO NOT EXCEED VEHICLE MANUFACTURER'S RECOMMENDED TOWING CAPACITY.

WARNING: ALL NON-TRAILER LOADS APPLIED TO THIS PRODUCT MUST BE SUPPORTED BY AUXILIARY STABILIZING STRAPS.

** FAILURE TO PROPERLY SUPPORT NON-TRAILER LOADS WILL VOID PRODUCT WARRANTY**

Parts List			
ITEM	QTY	PART NUMBER	DESCRIPTION
1	4	M12-1.75 x 40mm	HEX BOLT
2	4	1/2"	CONICAL TOOTHED WASHER

**RUBBER ISOLATOR
REMOVAL DIAGRAM**

This technique can be used if an Exhaust Hanger Removal Pliers is not available.

Using a 5/8" open end wrench, slide the wrench up to the rubber isolator, cradling the hanger rod as shown. Next place the flat edge of a pry bar between the wrench and the hanger stop or hanger rod. Then simply rotate the pry bar toward the wrench to remove the rubber isolator.

Note: Using a spray lubricant or soapy water on the hanger rod and the rubber isolator helps removal.

**TOOLS REQUIRED**

RATCHET
18mm SOCKET
8 in SOCKET EXTENSION
PRY BAR
TORQUE WRENCH

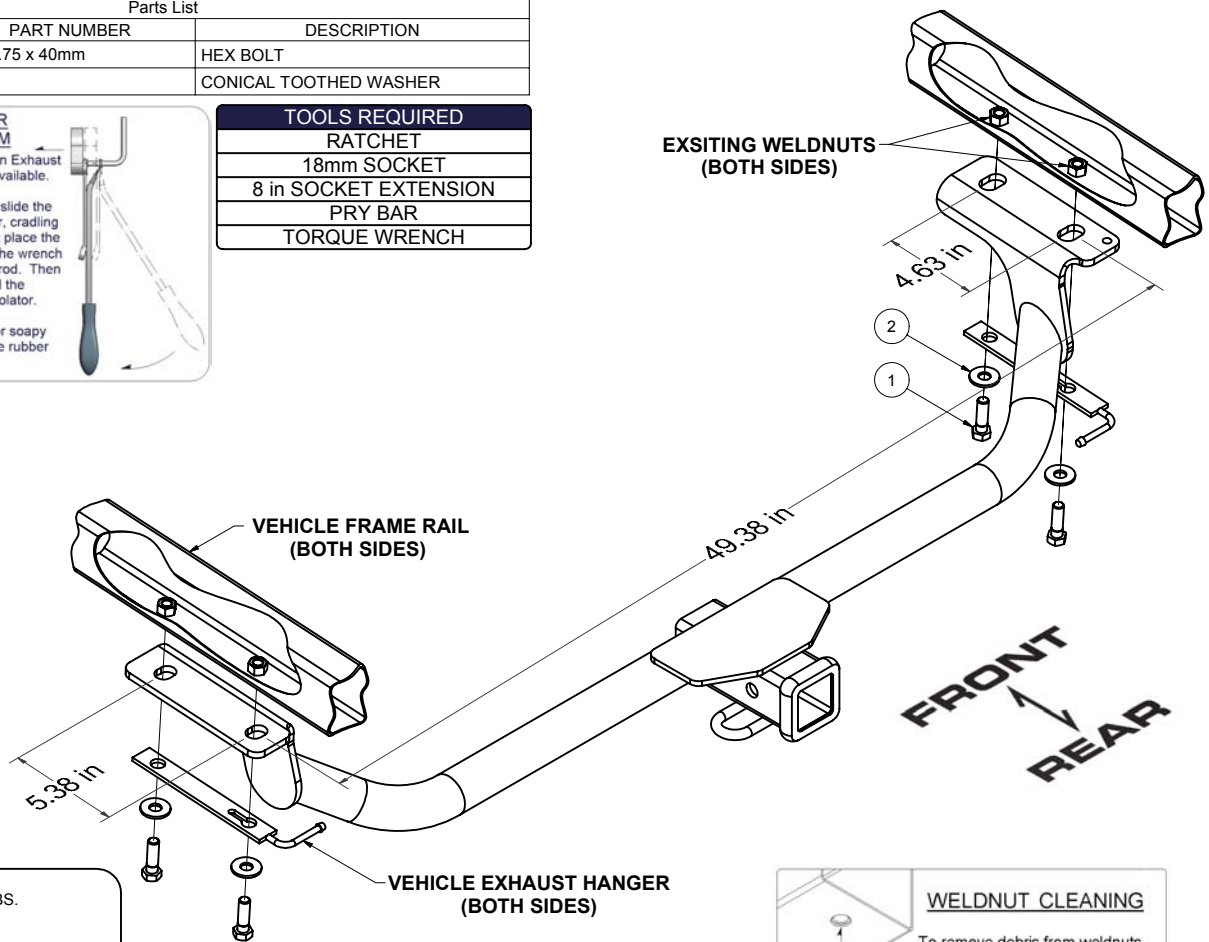
EXISTING WELDNUTS
(BOTH SIDES)

HITCH WEIGHT: 27 LBS.

INSTALL TIME

PROFESSIONAL: 40 MINUTES

NOVICE (DIY): 80 MINUTES

INSTALL NOTES:

- LOWER EXHAUST
- NO DRILLING REQUIRED

WELDNUT CLEANING

To remove debris from weldnuts in frame, spray lubricant or compressed air into hole. For heavy debris, use a small wire brush. (Be careful not to damage threads).

INSTALLATION STEPS

1. Remove (2) center rubber exhaust hangers. (See RUBBER ISOLATOR REMOVAL DIAGRAM)
2. Remove (4) M12x1.75 bolts which attach exhaust hangers to the vehicle frame rail. (Two bolts on each exhaust hanger)
Note: Be sure to support exhaust so it does not bend.
3. Place hitch so it is between the exhaust and exhaust hanger which is welded to the exhaust on both sides. Simultaneously raise hitch and exhaust into position.
4. Use included hardware to attach hitch and exhaust hangers to vehicle frame. Leave bolts loose.
Note: Hitch is sandwiched between frame and exhaust hanger.
5. Adjust hitch to allow maximum clearance between hitch and exhaust to avoid rattling.
6. Torque all M12x1.75 hardware to 60 ft-lbs.
7. Re-attach (2) center rubber exhaust hangers which were removed in STEP 1.

PERIODICALLY CHECK THIS RECEIVER HITCH TO ENSURE THAT ALL FASTENERS ARE TIGHT AND THAT ALL STRUCTURAL COMPONENTS ARE SOUND.

Curt Manufacturing Inc., warrants this product to be free of defects in material and/or workmanship at the time of retail purchase by the original purchaser. If the product is found to be defective, Curt Manufacturing Inc., may repair or replace the product, at their option, when the product is returned, prepaid, with proof of purchase. Alteration to, misuse of, or improper installation of this product voids the warranty. Curt Manufacturing Inc.'s liability is limited to repair or replacement of products found to be defective, and specifically excludes liability for incidental or consequential loss or damage.