

12272

2004-2007 CHEVROLET MALIBU - SEDAN ONLY

GROSS LOAD CAPACITY WHEN USED AS A WEIGHT CARRYING HITCH: 3500 LBS. TRAILER WEIGHT & 350 LBS. TONGUE WEIGHT.

*****DO NOT EXCEED VEHICLE MANUFACTURER'S RECOMMENDED TOWING CAPACITY.*****

WARNING: ALL NON-TRAILER LOADS APPLIED TO THIS PRODUCT MUST BE SUPPORTED BY AUXILIARY STABILIZING STRAPS.

**** FAILURE TO PROPERLY SUPPORT NON-TRAILER LOADS WILL VOID PRODUCT WARRANTY****

Parts List			
ITEM	QTY	PART NUMBER	DESCRIPTION
1	2	1/2 - 13 x 2"	CARRIAGE BOLT
2	2	CM-SP4	.250 x 1.50 x 3.00" SQUARE HOLE SPACER
3	2	HFN 1213	HEX FLANGE NUT
4	4	3/8-16 x 1 1/2	CARRIAGE BOLT
5	4	CM-SP18	.250 x 1.00 x 2.00" SQUARE HOLE SPACER
6	4	3/8"	CONICAL TOOTHED WASHER
7	4	3/8 - 16	HEX NUT
8	1	1/2"	FISHWIRE TOOL

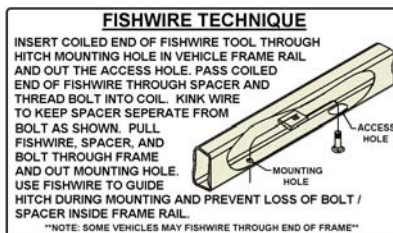
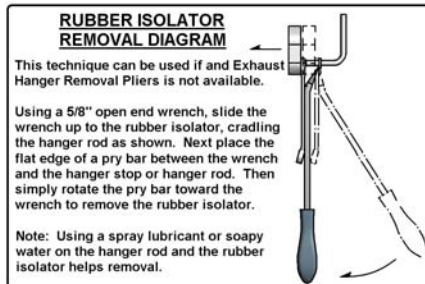
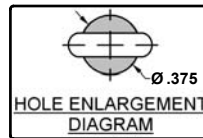

HITCH WEIGHT: 48 LBS.

INSTALL TIME

PROFESSIONAL: 30 MINUTES

NOVICE (DIY): 65 MINUTES

INSTALL NOTES:

- Hole enlargement required
- Fishwiring required

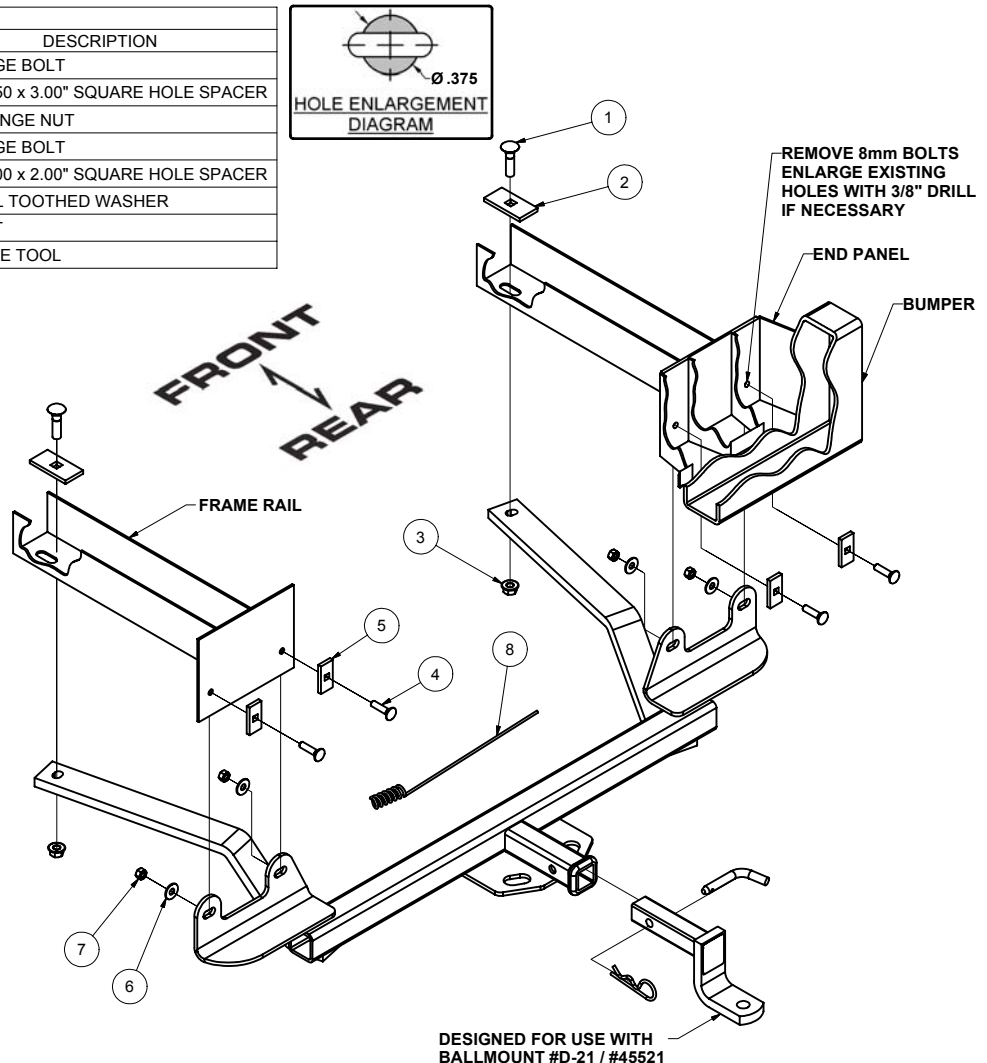
**INSTALLATION STEPS**

- 1) Lower muffler by removing the two (2) exhaust hangers.
- 2) Remove the bottom four (4) 8mm bumper bolts from the end panel. Do **NOT** loosen or remove the top bumper bolts.
- 3) Remove existing weldnut from end panel on the inboard side of frame rail.
- 4) If necessary, enlarge existing holes in end panel using a 3/8" drill.
- 5) Raise hitch into position, aligning slots in hitch with holes in vehicle end panel.
- 6) Loosely install the 3/8" carriage bolts, small spacer blocks, conical toothed washers, and hex nuts as shown.
- 7) Fishwire 1/2" carriage bolts and large spacer blocks through large slot in bottom of frame rail as shown.
Note: Keep bolt and block separate while inserting fasteners through slot.
- 8) Pull fasteners through, orient spacer block as shown. Loosely install conical toothed washers and hex nuts onto carriage bolts.
- 9) Torque all 3/8" hardware to 31 lb-ft. and all 1/2" hardware to 75 lb-ft.
- 10) Reinstall exhaust hangers removed in step 1.

PERIODICALLY CHECK THIS RECEIVER HITCH TO ENSURE THAT ALL FASTENERS ARE TIGHT AND THAT ALL STRUCTURAL COMPONENTS ARE SOUND.

Curt Manufacturing Inc., warrants this product to be free of defects in material and/or workmanship at the time of retail purchase by the original purchaser. If the product is found to be defective, Curt Manufacturing Inc., may repair or replace the product, at their option, when the product is returned, prepaid, with proof of purchase. Alteration to, misuse of, or improper installation of this product voids the warranty. Curt Manufacturing Inc.'s liability is limited to repair or replacement of products found to be defective, and specifically excludes liability for incidental or consequential loss or damage.